

21st WORLD MINING CONGRESS

# New Challenges and Visions for Mining

## 21st World Mining Congress

ABSTRACTS of ARTICLES  
WITH CONGRESS  
FRAMEWORK PROGRAMME



7-11 SEPTEMBER 2008 – POLAND  
KRAKÓW – KATOWICE – SOSNOWIEC



**8<sup>th</sup> September 2008**  
**Day 2 (Monday)**  
**The Grand Hall of Auditorium Maximum**  
**of Jagiellonian University,**

### **Plenary Session**

Venue: The Grand Hall of Auditorium Maximum, Krupnicza str.

#### **1<sup>st</sup> Part 9:00 a.m. - 1:00 p.m.**

Chairman: A.K. Ghose, Co-Chairman: Kazimierz Lebecki

Secretary: Eugeniusz J. Sobczyk

9:00 -9:05 a.m.

Opening

9:05 - 9:25 a.m.

Magnus Ericsson, *Raw Materials Group, Stockholm, Sweden*

#### **GLOBAL COMMODITY OUTLOOK AND IMPLICATIONS FOR THE MINING INDUSTRY**

Society's expectations of the exploration and mining industry are growing rapidly as metals supply becomes of political concern in the industrialised countries and stakeholders other than investors demand a larger share of profits. The global mining industry faces one main challenge: To deliver sufficient volumes of metals and minerals at prices, which do not fuel inflation or encourage substitution, while ploughing back a reasonable share of profits into local and national host economies. As the mining industry becomes less fragmented in the present wave of mergers and acquisitions a limited number of companies control an increasing share of the metal and mineral production globally. This trend has negative and positive implications. On the one hand, the mining industry needs to consolidate to create larger and stronger corporate entities. Only large companies have the necessary financial muscles to develop new low grade, but giant, deposits far from markets and existing infrastructure. Such companies can survive the next downturn in the markets. Larger companies are also necessary to fund and pursue increasing volumes of R&D including expanded exploration. Skyrocketing energy, water and environmental costs must be addressed and more innovative ways of operating must be introduced. On the other hand proper checks and balances must be in place to ensure that monopolistic powers are not created. Whatever the size of a mining company accountability, governance and transparency must become key concepts for all participants, both new and old, large and small, from Europe and Asia. The same strict demands on transparency, conduct and operational practices from reporting standards to health and safety routines should be imposed on all exploration and mining companies regardless of origin and size. There is an important role in this fight also for the broader international community. "Mining for Development" modelled on the successful Norwegian programme called Oil for Development is but one idea presently discussed between Nordic and developing countries.

9:25 - 9:45 a.m.

Tad Szwedzicki, *AusWest Pty Ltd, Perth, Western Australia*

#### **GLOBAL TRENDS IMPACTING ON THE MINING INDUSTRY**

Global trends during the last half of the 20th century have substantially changed the mining industry all over the world. There has been an evolution from a primarily economically oriented industry to a health and safety conscious, environmentally, socially and legally responsible industry. After World War II the major issues that impacted on the industry were occupational health and safety. Numerous mine disasters in many countries set new directions for mining legislation. In time, community perceptions and needs changed and the most important issues impacting on the global mining industry were environmental and social. In the 1980's many local communities started to protest against a perceived lack of

benefits to them from mining operations, the social impact of operations, and the environmental damages. These protests and actions put pressure on the industry in both developed and developing countries. In the 1990's the issues that have impacted on mine management have been legal and political. Mining has been affected globally by Court rulings, government decisions and regulatory restrictions. From the turn of the century consolidation is taking place within the industry. Mergers and acquisitions have been changing the mining scene and mega miners start to dominate the world's mining. Analysis of milestones in the mining industry indicates that during the last half of the century there has been a shift in the scale of impact of the trends impacting on the industry factors. From the 1950's to the 1970's the impact of trends was limited to mining practices. From the 1980's, the impact of trends had extended to individual mining companies. Recently, however, the trends have begun to impact the mining industry on a global scale.

9:45 - 10:05 a.m.

Xianzheng Wang, *China National Coal Association, China*

#### **DEVELOPMENT PERSPECTIVES OF CHINA MINING INDUSTRY**

In China, coal is the basic source of energy and constitutes the majority of primary energy. Coal accounts for 94% of the proven fossil fuel reserves, 76% of the primary energy production, and 69% of the social consumption. The reliability of Chinese coal resources, the stability in their supply, and the low price as compared with oil, give coal industry high status, outstanding role and obvious development advantage in the Chinese national economic and social development. As pointed out by Chinese Premier Wen Jiabao, it is a long-term principle for coal to stay the basis of Chinese energy, given the conditions of Chinese resources.

10:05 - 10:25 a.m.

John E. Tilton, *Colorado School of Mines, USA*

#### **LONG RUN AVAILABILITY OF NONRENEWABLE MINERAL RESOURCES**

The debate over depletion and the long-run availability of mineral commodities remains today as polarized as it was 35 years ago. This largely reflects uncertainties regarding future trends in mineral supply and demand, and uncertainties surrounding the environmental and other social costs associated with mining and mineral production. As a result, we simply do not know whether mineral commodities will become more or less available in the long run. Neither the optimists nor the pessimists can prove the other wrong. So perhaps the most reliable prediction about the future threat of mineral depletion is that the debate will continue. While this is disappointing, we have learned much from the on-going debate. We know now that mineral scarcity is not inevitable: technological change can offset the effects of depletion, and as a result mineral commodities can actually become more available over time. In fact, this has been the case for many mineral commodities over the past century. We know that it is economic not physical depletion that we have to fear, which means if scarcity occurs it will not be a surprise but instead manifest itself slowly by persistent increases in real mineral commodities prices over years and decades. While many believe that slowing population growth and reducing mineral consumption help promote the long-run availability of mineral commodities, we now know that this need not necessarily be the case. Both in their own ways can promote availability. Finally, we know that the mix of mineral commodities used in the future will be different, and what matters for the future of humankind is that society can satisfy its mineral resource needs at real costs not substantially above those of today.

10:25 - 10:40 a.m.

Harald Lissberg, *WIRTGEN, Poland - commercial presentation*

#### **PRODUCT RANGE & WORLD-WIDE ACTIVITY IN THE MINING SECTION**

10:40 - 11.00 a.m.

Coffee break

11:00 - 11:20 a.m.

Horst Wagner, Günter Tiess, *University of Leoben, Austria*

### **MINERALS PLANNING POLICIES AND SUPPLY PRACTICES IN EUROPE**

The paper describes the link between economic development and mineral consumption. The economic up-surge in population rich countries has resulted in supply shortages of key mineral commodities and the need to look into minerals planning policies. The main results of a study of minerals planning policies of the Member States of the EU are presented. Strategic options proposed by the DG Enterprise are discussed and the results of a consultation with stakeholders in the minerals industry presented. Key issues are: increasing the supply of raw materials from European sources on a sustainable basis ensuring sustainable and more transparent supply of raw materials from third countries encouraging capacity building in developing countries encouraging greater efficiency in the use of resources establishing an adequate EU knowledge base on raw materials. For each of these issues action plans are proposed and the reactions of stakeholders are reported. It is found that in some areas there are broad gaps between policy intentions and stakeholder views. Conclusions complete the paper.

11:20 - 11:40 a.m.

Jerzy Buzek, *Member of the European Parliament, Poland*

### **EUROPEAN WAY TOWARDS ZERO EMISSION CARBON TECHNOLOGY**

11:40 - 12:00 a.m.

Ben Peachey, *International Council on Mining and Metals (ICMM), United Kingdom*

### **SUSTAINABLE DEVELOPMENT FOR SUSTAINABLE INDUSTRY GROWTH**

12:00 - 12:20 p.m.

Niall Weatherstone, *Committee for Mineral Reserves International Reporting Standards (CRIRSCO), United Kingdom*

### **STANDARDS FOR REPORTING OF MINERAL RESOURCES AND RESERVES-STATUS, OUTLOOK AND IMPORTANT ISSUES**

Developing and maintaining international standards for the reporting of Mineral Reserves, Mineral Resources and Exploration Results is important. With an increasingly globalised mining industry, the commodity wealth of countries attracting strong political attention and the impact that minerals have on the financial, accounting and investment communities, the need for common terminology and understanding across country boundaries and language barriers has never been higher. Within countries many minerals reporting systems have been established: some by governments for governments, others by professional and industrial bodies for commercial use. The problem is that these systems don't "talk" to each other; just like children of different countries, they come from different backgrounds and speak different languages. This was not so much of a problem in the past as presumably within country borders, there was a general understanding of how the various systems operated and related to each other. Now, however, the globalisation of the mining industry, shown by cross border mergers and acquisitions, corporate listings on multiple international stock exchanges and increasing investment by foreign countries in the developing countries of Asia, Africa and South America, means that an international language is needed to describe the assets of mining companies, and ultimately the mineral wealth of countries. This paper discusses the current status in the development of international standards for reporting Mineral Reserves, Mineral Resources and Exploration Results. It provides a little bit of history, examines current activities and future trends, and identifies some of the issues that need to be addressed to achieve real international understanding of the categories of mineralisation that underpin the mining industry and its ability to supply the increasing demands of its consumers.

12:20 - 12:35 p.m.

Werner Ochse, *Dräger Safety, Poland* - commercial presentation

**MASK WITH DRINKING DEVICE FOR PSS BG 4**

12:35 - 1:00 p.m. Discussion

1:00 - 3:00 p.m. Lunch

**2<sup>nd</sup> Part 3:00 - 6:30 p.m.**

Chairman: Leopold Weber, Co-Chairman: Bolesław Firganek,  
Secretary: Eugeniusz J. Sobczyk

3:00 - 3:20 p.m.

A.K. Ghose, *Indian School of Mines University, India*

**SUSTAINABLE DEVELOPMENT IN WORLD MINING INDUSTRY IN THE LIGHT OF THE NEW DELHI DECLARATION - NDD**

Sustainable mineral development is a key issue of our times as New Delhi Declaration (2003) so rightly underscored. At this historic 50th anniversary of the World Mining Congress, it is only appropriate that the mineral industry, using appropriate sustainability criteria and metrics, takes stock of the progress of the industry towards sustainable development, which is essentially a journey towards excelsior in terms of environmental performance and good governance to cater to the great “minerals hunger” of the burgeoning global population (Ghose 2004). The world faces today two minerals-related threats that of not having adequate and secure supplies of mineral raw materials at affordable prices and that of environmental degradation caused by consuming too much of it. Of greater concern is the responsible management of all environmental assets – water, air, land, forests, habitat and biodiversity and the need to switch to more sustainable practices has never been more pressing. Sustainable development is a *mantra* that we have been chanting ever since the dawn of civilization. Only we had not coined this many splendoured buzzword until the Brundtland Commission (1987). Mineral industry developments, from the times of Kautilya (circa 330 BC), were governed by the imperatives of maintaining ecological integrity; but the problem dimension was a miniscule (Ghose 2002). As society and technology developed, the world has become ever more minerals hungry and inevitably the scale of impacts – the so-called ecological footprint has assumed a gargantuan dimension. Even if “sustainable development” applied to mineral resources is an oxymoron, finite as mineral resources are, technology provides the basic tools to stave off the crisis of “mineral famine” through innovative solutions in the areas of exploration, extraction, safety and environmental management and pushing the sustainability envelope. In its quintessence, sustainable mineral development is all about maintaining a balance between supply and demand, equitable capital distribution, sound risk-free environmental management and governance, contributing overall to global economy and poverty reduction. This is the daunting challenge that the mineral industry and the world faces in the 21st century and beyond. Prof. Bolesław Krupinski conceived the world mining congress as the seed bed where the mining fraternity could germinate technological solutions through *concerted efforts, capacity-building and cooperation, for a coordinated*. International response for the sustenance of a global mineral industry that endures. Through New Delhi Declaration (2003), the global mining industry reaffirmed the basic imperatives of sustainable mineral development. We examine here the strides made by global mineral industry towards sustainability since New Delhi and identify the key areas that call for priority attention in the action agenda.

3:20 - 3:40 p.m.

Ray Durrheim, *CSIR and University of the Witwatersrand, Johannesburg, South Africa*

### **ROCK ENGINEERING FOR ULTRA-DEEP MINING - RESEARCH, IMPLEMENTATION AND RESPONSIVE REGULATION**

Many mining excavations are situated in overstressed regimes where the rock surrounding any void will fracture and fail, regardless of the rock-breaking method or shape of the excavation. The failure may be violent and associated with seismic events, which are a major hazard of deep-level mining in South Africa. Recent initiatives to minimize the rock-related risks of ultradeep mining through research, implementation and regulation are described and assessed.

3:40 - 4:00 p.m.

Pekka Sarkka, *Helsinki University of Technology, Finland*

### **INTELLIGENT MINE IMPLEMENTATION**

Mining is commonly seen as a typical basic industry with rough and even dangerous working conditions, heavy environmental load, and a low level of high-technology and automation with much manual work and operations. A mining operation (open pit or underground) is a very complex one consisting of many manual, physical, mechanical and logistical operations with different human interfaces and decisions. For this reason it is a demanding and potential area for all applications of automation and information technology: controlling difficult non-linear, time varying multivariable processes and machines; solving of ergonomic safety and environmental problems; automation of logistical systems; applying robotics, mechatronics, and information handling, etc. In addition to that, big economic sums are involved with these operations. On the other hand, automation technology has developed towards intelligent and adaptive systems including some from the above mentioned fields of automation. Connecting them with modern information and communication technologies makes the idea of an intelligent and unmanned mine more and more feasible in the near future. This requires intensive co-operation and co-ordination between the mining industry and manufacturers of mining machinery. This has been successfully accomplished in the 5 year Intelligent Mine research and development program as well as the 3 years of subsequent implementation of its results in Finland. The basic elements of an Intelligent Mine concept are: mine-wide information and data acquisition system, high-speed two-directional mine-wide communication network for real-time monitoring and control, computerised information management, mine planning, control and maintenance systems, automated and tele-operated machinery and equipment which are connected to the information system, and links to the public information networks. The degree of automation of an intelligent mine depends on many technical and economical factors. The basic precondition for such an approach is that it will improve the total economy of the mine. This paper will describe the Intelligent Mine Technology Program with the results. Also the implementation which took place during the construction of new underground mines will be described.

4:00 - 4:20 p.m.

Carsten Drebenstedt, *Technische Universität Bergakademie Freiberg, Germany*

### **ENVIRONMENTAL MANAGEMENT - FROM MINERAL EXPLORATION TO MINE CLOSURE**

The life time of a mining project begins with the first detection of a mineralization up to the reintegration of the influenced area after the extraction of the minerals back into the society. In this period of time several activities impact to the area: exploration, preparation of the mining field for excavation (dewatering, resettlements, relocations of natural and infrastructure objects, ...), erection of infrastructure (mine camp, workshops, ...), extraction and processing of waste and minerals, activities of reclamation and mine closure, long term monitoring after mining. These activities impacts onto the existing before mining natural and socio-cultural structures in the mining area. Mining projects can change the natural and social situation in the area seriously for a long time. In regularly we well know the date of discovering the deposit, the beginning and the end of the mineral extraction, but: when finally ends the mining projects? Often, up today, mining activities goes after a comparable short profitable time from the site without reintegration of the area and the impacts to the society last decades and partly hundred of years. This situation depends on the development stage of the society by self: the legal, administration and technical instruments on one site and the education, sensitivity and responsibility of the acting

people on the other site. Today responsible mining companies can act in correspondence with the state of art of low impact mining from exploration up to sustainable mine closure.

4:20 - 4:35 p.m.

T. Jakubowski, R. Bednarz, *The Famur Group, Poland*

#### **MEETING THE CHALLENGES OF 21ST CENTURY MINING FAMUR GROUP**

The combination of capital, experience, tradition and know-how makes the FAMUR Group one of Poland's major producers of machines and equipment for the mining sector and an acknowledged partner worldwide. The FAMUR Group is characterised by a dynamic growth in the scale of its operations and a consistent, very high profitability. From the outset, the FAMUR Group development strategy, has been focused on creating, through acquisition and capital investments, a strong Group specialising in manufacturing and delivering state of the art equipment for longwall systems and the underground transport of materials and personnel. The Group comprises companies manufacturing machines for such systems. At FAMUR Group, we believe in ensuring product and manufacturing technology innovation through regular investment in research and development. All the machines and equipment manufactured by the Group's affiliates are designed in line with the latest technological trends. Thanks to the combination of experience, know-how and tradition found in the FAMUR Group's design departments, our customers always receive products incorporating design and technological solutions which are both innovative and reliable. What make this possible is the creativity of our designers and the support of advanced computer systems and state of the art software at the designing stage. This innovative approach allows for the design of customised machines and equipment and, particularly, machinery and equipment designated for use under the toughest operating conditions. The FAMUR Group believes in close cooperation with contractors, ensuring the maximum capacity for the equipment as well as safe working conditions. Our high efficient service enables all repairs and services to be carried out and means that the equipment will be maintained in good technical condition past the warranty period. All of these factors, supported by our belief in the need for constant development, place the FAMUR Group among the world's leading companies offering complete extraction systems for hard coal mines.

4:35 - 5:00 p.m.

Coffee break

5:00 - 5:20 p.m.

Michael Karmis\*, Scott Keim\*\* (paper presented by Hans E. Naumann\*\*), \**Virginia Tech, Blacksburg, Virginia, USA*, \*\**Marshall Miller & Associates, Bluefield, Virginia, USA*

#### **THE FUTURE OF COAL - A USA PERSPECTIVE**

This paper discusses the current status of the coal industry in the US and the future opportunities and challenges for the sector. The US coal industry is the second largest in the world, producing over 1.1 billion short tons of bituminous coal in 2007 and accounting for about 23 percent of total US energy consumption. The electrical power generation sector consumes 91 percent of the domestic coal production and about half of the nation's electricity is from coal-fired generation. The authors present the latest forecasts for coal production, discuss coal supply and demand trends, and provide an insight on the role, production potential and future challenges of the major coal producing regions in the US. The paper also identifies the technical, geological, safety, environmental, regulatory, operational, and community engagement opportunities and challenges that can impact coal development, production, and viability. The potential for long-term negative interruptions to the coal supply chain, arising from the strong interdependence between the ability to rapidly increase production capacity in the mines to capture favorable markets, and the long lead times required to progress from mine planning to mine production, are also discussed. Business uncertainties have a negative effect on the growth of the industry and are further exacerbated by concerns arising from tentative forecasts of coal demand, questionable access to capital, changes in health, safety and environmental regulation, a pending workforce crisis, transportation and infrastructure limitations, community acceptance of coal-fired generation and other coal utilization processes, and future climate change regulation. Specific discussion is devoted to the issue of global warming and the impacts and limitations on the coal sector under carbon-constraint policies. The possibilities of carbon capture and storage technologies, currently under various states of



development and deployment, are also noted. Finally, conclusions are offered as to the role, challenges and sustainability of the US coal industry.

5:20 - 5:40 p.m.

Maksymilian Klank, *European Association for Coal and Lignite, Poland*

#### **FUTURE OF COAL - FROM EUROPEAN PERSPECTIVE**

The paper briefly discusses Euracoal as the umbrella organisation of European coal industry, brings attention to the situation of coal, both hard coal and lignite, in selected member states of the UE – coal producers, examines the challenges, opportunities and risks facing the European coal industry, discusses some aspect of climate protection connected especially with development and implementation of CCS technology and emission trading system in the EU.

5:40 - 6:00 p.m.

R.N. Singh\*, A.S. Atkins\*\*, D. Mamurekli\*\*\*, M. Mamurekli\*, *\*University of Nottingham, United Kingdom, \*\*Staffordshire University, United Kingdom, \*\*\*Celal Bayar University, Turkey*

#### **REVIEW OF THE COAL MINING INDUSTRY IN THE UK 2008**

In this paper the importance of coal mining in relation to total energy demand in the UK is discussed. Since the era of industrial revolution from 1780's until 1971 coal has remained a primary source of energy in the UK. However, competition from oil and gas, environmental problems associated with the utilisation of coal, union disputes in the coal industry and the international price of cheap imported coal resulted in the decline of the coal industry in the 1980's and the eventual privatisation of the industry in 1994. In this paper, the current state of the coal mining industry in the UK is discussed together with the various factors which affect the future of coal mining.

6:00 - 6:20 p.m.

Antoni Tajduś, Marek Cała, *AGH University of Science and Technology, Poland*

#### **TRENDS AND PERSPECTIVE OF POLISH MINING INDUSTRY**

Poland is one of the countries rich in various minerals. There are significant deposits of hard coal and brown coal, copper ore, zinc and lead ore, rock salt, native sulphur, gypsum, kaolin, rock minerals, remedial and geothermal waters, as well as some deposits of natural gas and small volume of oil. The paper discusses in more detail the volumes of the resources, the problems related to their extraction and the perspectives of several of the most important Polish mine plants, that is: hard and brown coal, copper ore, zinc and lead ore, sulphur, natural gas and oil.

6:20 – 6:35 p.m.

Karl-Heinz Gerlach, *Siemens AG, Industry Sector, I IS MT MI, Germany*

#### **A COMPLETE AUTOMATION PACKAGE FOR MINING OPERATIONS**

Simine<sup>o</sup> integrated mining solutions include the control, monitoring, display, and optimization of mining production from excavation through transport to processing and secondary processes to include water treatment or storage. With Simine<sup>o</sup> CC (Control Center) and Simine<sup>o</sup> MES (Manufacturing Execution System), Siemens has developed solutions whose modular design, technical consistency, and specific mining features combine to provide a virtually unlimited number of ways to adapt mining control technology to individual processes and requirements ... *You can read full article at the page no 125.*

6:35 p.m. – 6:45 p.m.

Discussion

6:30 - 8:00 p.m.

Dinner

**8:00 p.m. Official parade from Auditorium Maximum of the Jagiellonian University to Main Market Square of Krakow starts**

**8:30 – 10:00 p.m. – Performance: “Mining Traditions - Jump over a leather apron”, Main Market Square of Krakow**

The culmination point of the accompanying events to 21st World Mining Congress is an open air artistic event performed against the background of Cracovian market Mining Traditions - Jump over a leather apron. Event programme envisages evening parade of the participants of the Congress and invited guests in the light of the torches from the building of Auditorium Maximum of the Jagiellonian University to the Townhall in the Market Square where artistic performance showing the beauty of Polish and European mining traditions will take place.

**10 September 2008, 9.00 a.m – 6.45 p.m**  
**The Grand Hall A, Auditorium Maximum of the Jagiellonian University**  
**(35 Krupnicza str.)**

## **Session 1: New technologies in mining**

**Venue: The Grand Hall A, Auditorium Maximum**

Chairman: Hans E. NAUMANN, Co-Chairman: Piotr CZAJA  
Secretary: Tomasz NIEDOBA

### **Block A : New technologies in mining - Equipment**

9.00 - 9.15 a.m.

Artur Mazur, *DFM ZANAM-LEGMET Ltd, Polkowice, Poland*

#### **APPLICATION OF MECHATRONIC SYSTEM IN WHEEL MINE LOADERS**

Since the '90s, in the construction of off-road mobile machines and construction equipments, OEM started to use the electronic control systems. The development of hydraulic, engine control and data transmission systems made possible an application of mechatronic devices, even in the very heavy exploitation conditions as underground mining systems. This article presents the achievements of DFM Zanam-Legmet Ltd in the field of mechatronic techniques in his products, especially in the wheel mine loader LKP-0903. The author presents the thesis that only mechatronic systems of control can meet the growing requirements of customers in the scope of exploitation and reliability of mining machines.

9.15 - 9.30 a.m.

Martin JUNKER *Central Production Division and Central Technical and Controlling Division of RAG, Herne, Germany*

#### **INTELLIGENT MACHINES AND SYSTEMS IN THE GERMAN HARD COAL MINING INDUSTRY**

Within German hard coal mining, the development of innovative mining technology has been driven forward in particular by the requirement to make more effective winning, heading and logistic equipment available to the industry. Despite the fact that mining is restricted to evergreater mining depths (1000 m to 1520 m) and despite the resulting higher rock temperatures (up to 60°C), high primary rock pressures (around 26 MPa) and multi-seam mining (119 workable seams, with 21 seams being mined simultaneously), the German hard coal mining industry has succeeded in doubling its performance figures. Further requirements regarding this state-of-the-art technology and machinery will be influenced by the objective of automating the machinery and making it "intelligent". Based on this, all mining activities must be considered from a process-related point of view, which means that different items of machinery have to be linked and developed so that they can communicate amongst themselves. Because automatic, intelligent equipment and its systematic monitoring will result in safe, controlled methods and procedures, the overall safety of the workforce will also be improved.

9.30 - 9.45 a.m.

Emanuel Z. MANOS, *Detroit Salt Company L.C., Detroit, Michigan, USA*

#### **CONTROLLING DIESEL PARTICULATE MATTER EXPOSURES UNDERGROUND USING SOY BIODIESEL**

USA Federal regulations restricting diesel particulate matter (DPM) exposures to 160TC µg/m<sup>3</sup> in underground metal-non metal mines have compelled the industry to consider a range of DPM control strategies. These strategies range from controlling exposure limits by improving the ventilation, envi-

ronmental cabs and administrative management to emission reduction methods with advanced engine designs, aftermarket engine filters and the use of innovative diesel fuels. An innovative approach using 100% soy based diesel fuel was tested by two USA salt mines one in Hutchinson, Kansas and the other in Detroit, Michigan. From the results of those studies, 100% soy biodiesel use has increased in other mines to insure compliance with the federal regulations. The history, composition, test trials and subsequent data resulting from the use of 100% soy based diesel in USA underground mines will show that this alternative fuel can be utilized as a viable DPM control strategy.

9.45 - 10.00 a.m.

A.A. Repin, S.E. Alekseyev, *Institute of Mining, Siberian Branch, Russian Academy of Sciences, Russia*

**AIR-PERCUSSION REAMER: PRACTICAL EXPERIENCE AND FUTURE PROSPECTS**

The evolution of the air-percussive drilling machinery is reviewed. Authors give grounds for a changeable drilling tool to be used as a reamer assembled on downhole air hammer P150, the basic diagram and specification of P150 being presented together with some of its pilot test data. The designs of the changeable drilling tool and its stress state simulation are described. The prospects for using reamers to drive raising technological, blast and balancing holes are discussed.

10.00 - 10.15 a.m.

Jörg Arloth & Armin Heller, *PC-Soft GmbH, Siemag M-Tec2 GmbH*

**TECHNICAL MANAGEMENT OF CONVEYING SYSTEMS BASED ON THE EXAMPLE OF THE SIEMAG M-TEC2 SHAFT HOISTING SYSTEM PROJECT AT THE GOTTHARD BASE TUNNEL**

For the construction of the world's largest railway tunnel in Switzerland, thousands of tons of rock, men and material have to be moved above and below ground every day. With regard to rough environmental and operating conditions underground, technical demands on control engineering, drive systems and safety features of shaft hoisting systems are tremendously high. In order to fully respond to these requirements, the operator SIEMAG M-TEC2 implemented the plant management system for condition monitoring and condition-based maintenance by PC-Soft. Based on this strategy, SIEMAG M-TEC2 can improve production reliability, plant availability and work efficiency.

10.15 - 10.30 a.m.

Discussion and comments

10.30 - 11.00 a.m.

Coffee break

**Block B - New technologies in mining - Extraction**

11.00 - 11.15 a.m.

K.N. Trubetskoy, YU.P. Galchenko, G.V. Sabyanin, *Institute of Problems of Complex Development of Bowels of the Earth of the Russian Academy of Sciences, Russia*

**CONCEPT OF SUBSURFACE DEVELOPMENT OF BOWELS OF THE EARTH ON THE BASIS OF "FRAMEWORK" GEOTECHNOLOGY**

Technological pressure on natural ecological systems during extraction of Earth subsurface resources leads to irreversible changes of those systems. This impact quickly becomes global in nature. Internal dynamic of mining industry influence on the environment is defined today by the increasing contradiction between the constant market demand of mining exploration cost reduction, and ecological necessity to preserve the environment in its entirety. Evolutionary development of geo-technologies historically did not take into account the importance of ecological factors. Consequently, the increase in productivity

and profitability of applied mining technologies is accompanied by rapidly increasing destruction of nature and environmental contamination. Implementation of Frame Geo-Technology for underground subsurface resources exploration can provide us with unique opportunity to overcome this contradiction.

11.15 - 11.30 a.m.

G.G. Pivnyak, Y.A. Kyrychenko, V.P. Franchuk, *National Mining University, Dnipropetrovsk, Ukraine*

### **PROBLEMS OF DEEP-WATER HYDRAULIC LIFTING OF SOLID MINERAL RESOURCES**

The design procedure of parameters of deep-water hydrorises in view of transported material crushing is offered. The mechanism of destruction of a transported material in airlift- and pump-based deep-water hydrorises is studied. Preliminary conclusions and selective qualitative results of influence of the specified process on parameters of installations are given. The algorithmic software of the offered method was developed. Technical offers on updating of technological processes are given.

11.30 - 11.45 a.m.

P. Afzal, *Islamic Azad University, Science and Research Branch, Hampa Behineh Engineers Consultant Co., Tehran, Iran*, M. Nikzad, *Hampa Behineh Engineers Consultant Co., Tehran, Iran*, D. Kaveh Ahangaran, *Islamic Azad University, Tehran South Branch, Mining Engineering Department, Tehran, Iran*

### **EXPLORATION OF VALUABLE EVAPORATE MINERALS IN CENTRAL IRAN**

Many plays are found in Iran but most of them were not extracted. One of the important plays is Mighan in central Iran. The purpose of this research is exploration of valuable evaporate minerals in Mighan Playa. In this play 148 boreholes were drilled which has 6 meters depth and grid drilling was 500×500 m. Then 105 samples were taken and analyzed in order to determine the contents of the components. 8 piezometric boreholes were drilled and porosity, transmissivity and storativity were calculated. Finally the play was 3D-modeled basing on mineralogy and stratigraphy as well distributions of Na<sub>2</sub>SO<sub>4</sub>, Mg<sub>2</sub>SO<sub>4</sub>, NaCl, CaSO<sub>4</sub> and their reserves. Calculation of mineral reserves shows that mirabilite reserve is equal to 42.9 Mt and gluberite reserve – 127.4 Mt. The studies on 3D-modeles show that the best accumulation for mining extraction is situated in centre, south and south-western part of the studied area.

11.45 - 12.00 a.m.

P. Vihanto, *Talvivaara Project Ltd, Sotkamo, Finland*

M. Vanhanen-Riekkola, *Talvivaara Mining Company Plc., Sotkamo, Finland*

### **TALVIVAARA MINE, FINLAND – BIOHEAPLEACHING OF POLYMETALLIC NI-ORE IN SUBARCTIC CLIMATE**

The main activity of the Talvivaara Mining Company Plc. (the Group) is the development and exploitation of the Talvivaara Deposits in Sotkamo, Finland, using technology known as bioheapleaching. The Talvivaara Deposits comprise one of the largest known sulphide nickel resources in Europe with 452.7 million tonnes of ore in measured and indicated categories, sufficient to support anticipated production for a minimum of 24 years, starting in late 2008, with an annual nickel output of approximately 33,000 tonnes. In addition, the mine is also expected to produce zinc (approximately 60,000 tpa), copper (approximately 10,000 tpa) and cobalt (approximately 1,200 tpa) as by-products of the process. The Talvivaara Project Ltd, a company 80 per cent, owns the rights to the Talvivaara Deposits owned by the Talvivaara Mining Company. Since acquiring the rights to mine the Talvivaara Deposits and the rights to use the related geological and bioheapleaching research data in February 2004, the Group has actively pursued the development of the Talvivaara Deposits and, on 23 March 2007, the board of directors of the Talvivaara Project Ltd approved the Bankable Feasibility Study, which contains detailed estimates of all material capital and operating expenditures expected to be incurred in connection with constructing and operating the mine. The Group has also obtained an environmental permit and other material permits required for the commencement of mining operations. Further work on the Talvivaara Project will

involve the development of the Talvivaara open pit mines, the construction of processing and ancillary infrastructure and the design, construction and commissioning of a processing facility. The Group is expecting to benefit from the proximity of the Talvivaara Project to existing energy and transportation infrastructure and potential customers. The Group plans to supply metal intermediaries to companies with metal refining operations. Planned products are mixed nickel cobalt sulphide, zinc sulphide and copper sulphide. The Group has already entered into a 10-year Off-Take Agreement with Norilsk Nickel Harjavalta for the entire output of the mine's nickel and cobalt production at market prices. The Group plans to develop the Talvivaara Deposits using technology known as bioheapleaching. This technology is already widely used for other metals, notably copper and gold. Bioheapleaching harnesses locally occurring, live bacteria for the extraction of metals from ore. In the leaching process, crushed and agglomerated ore is stacked in heaps, which are then irrigated with leach solution and aerated. During the last three years, the Group has demonstrated the viability of using bioheapleaching technology for the extraction of nickel in large on-site pilot trials using the Talvivaara ore. The trials have shown the leaching process to be heat generating and therefore suitable for the sub-arctic climatic conditions of Eastern Finland. Consequently, the bioheapleaching technology used by the Group is expected to enable commercial utilisation of the Talvivaara Deposits.

12.00 a.m. - 12.15 p.m.

V.V. Novikov, S.V. Novikov, A.V. Korzakova & V.I. Malahovskiy, *EGONT Ltd (Ecological Ore-Dressing New Technology), Saint Petersburg, Russia*

#### **ALTERNATIVE EXPLOITATION TECHNOLOGY OF MINERAL DEPOSITS**

In the present research work, we offer a technology and instrument for mining of mineral deposits. The technology is based on the preliminary mineral concentration. The instrument is represented with the use of non-contact measurement of the geophysical properties of the ore products. The technology is analyzed in the application of the wolfram, molybdenum and fluorite containing deposits.

12.15 - 12.30 p.m.

Garry G. Litvinsky, *The Donets Basin' State Technical University, Alchevsk, Ukraine*

#### **THE SCIENTIFIC DOCTRINE OF MANLESS MINING "THE 21ST CENTURY PIT"**

For the first time the scientific doctrine of underground coal mining "The 21st Century Mine" is offered and proved. The initial projects of essentially new samples of mining engineering are developed for manless coal mining from thin gaseous seam on the large depths: frontal road heading machine "MIR" for a high-speed roadway driving, frontal auger mining and quarystone aggregates, hydrojack ropeless hoisting and pipeless pumping, new universal opening and support system of coal deposits with use of the original circuits gas exchange, ventilation, energy supply and safety. The account of the technical and economic indices of new mine is executed. The advantages of innovation model of development of a mining are shown.

12.30 - 12.45 p.m.

H. Copur, C. Balci, N. Bilgin, D. Tumac, *Istanbul Technical University, Mining Engineering Department, Istanbul, Turkey*

#### **LABORATORY CUTTING TESTS FOR PERFORMANCE PREDICTION OF CHAIN SAW MACHINES**

Preliminary results of a project supported by TUBITAK (The Scientific and Technological Research Council of Turkey) are presented in this paper. Block natural stone samples are obtained from quarries in Turkey to perform a set of full-scale laboratory linear rock cutting tests using chain saw cutting tools to determine cutting characteristics of chain saw machines and sample cuttability, in addition to some physical and mechanical property tests. Full-scale laboratory linear rock cutting tests result in tool forces and specific energy to cut a unit volume of rock. These tests can be used to define optimum cutting configuration for a certain stone type by reducing torque and thrust requirement of the machine, thus

increasing machine performance. There are problems in extraction of high strength and abrasive natural stones such as marbles and granites. The problems mainly are low production rates, high cutting tool consumption rates, and thus, high costs. Chain saw machines are used for cutting low to medium abrasive and soft to medium strength natural stones, in both underground and surface quarrying operations. The miners usually use standard chain saw machines for cutting every type of natural stones. However, it is very well known in rock cutting mechanics that as the rock properties change, the optimum cutting conditions change, as well. Therefore, the lacing pattern of the tools should be different for different stones to obtain better performance. A beige marble sample obtained from a quarry in Turkey is subjected to a set of investigations and experimental program in the laboratories of the ITU Mining Faculty Mining Engineering Department. The block sample is cut using cutters of different sideways angles (0°, 15°, 30° and 45°) in the linear cutting testing set in unrelieved cutting mode at different cutting conditions (depth of cut, cutter spacing, etc) to find out sample cuttability (cutter forces, specific energy, optimum cutting geometry). However, only the unrelieved cutting test results are presented in this study. The results indicate that linear cutting tests make possible to deterministically simulate the cutting action of a chain saw machine, better understand the cutting characteristics of chain saws, develop optimum lacing designs for a given stone type and predict and optimize machine performance.

12.45 - 1.00 p.m.

Discussion and comments

1.00 - 3.00 Lunch

### **Block C - New technologies in mining - development**

3.00 - 3.15 p.m.

Anatoliy A. Kozhevnikov, *National Mining University, Dnipropetrovsk, Ukraine*

Anatoliy D. Begun, *"Volkovgeology" Co. Ltd, Almaty, Kazakhstan Republic*

#### **WELL BORING IMPULSE TECHNOLOGIES ARE THE TECHNOLOGIES OF THE 21ST CENTURY**

The authors examine the well drilling impulse technologies classification that includes such drilling techniques as monoparametric, biparametric and threeparametric. Theoretical foundation of monoparametric technique of long well drilling with the use of high-frequent hydropercussion machinery with hydraulic wave reflectors was designed. Suggested criteria of rotary-percussion drilling efficiency are confirmed by boring conducting practice.

3.15 - 3.30 p.m.

Tomasz Białożył, Wojciech Bochenek, Henryk Passia, Tadeusz Smoła, Adam

Szade, Mariusz Szot, *Central Mining Institute, Katowice, Poland*

#### **NEW DEVELOPMENTS OF LASER-BASED MEASURING EQUIPMENT FOR CONTROL OF THE CONDITION OF VERTICAL AND HORIZONTAL MINE WORKINGS AND STRUCTURES IN MINING-AFFECTED AREAS**

The paper presents new solutions in the field of mining lasers and associated measuring equipment, as applied to control the condition of mine workings, horizontal and vertical, and to perform monitoring of structures on the surface. With the aim to control rectilinearity of shaft lining and guides, a laser-based measuring set has been developed within the course of realisation of a dedicated research project. The measuring set applies an original method for determining and recording the laser beam position in the space. The technical characteristics of the designed equipment have been presented, and results of field tests discussed. The monitoring of structures threatened with underground mining is being conducted with the use of a set of laser tilt and vibration sensors provided with a system of automatic recording and remote transmission of data. In particular cases, the condition of a structure is investigated using a laser Doppler scanning vibrometer.

3.30 - 3.45 p.m.

S. Khomeriki, R. Mikhelson, D. Khomeriki & K. Dzebisashvili, *L.P.P.L. G. Tsulukidze Mining Institute, Tbilisi, Georgia*, H. Tudeshki & S. Roszbach, *Technical University of Clausthal, Germany*

**DEVELOPMENT OF TECHNOLOGY AND CREATION OF INDUSTRIAL EXPLOSIVES BASED ON WASTE MILITARY AMMUNITION**

In many states of the former Soviet Union there are many waste dumps at military bases where the ammunition is past its expiry date. Disposal in landfill either by incineration or explosion leads to environmental problems and requires considerable expenditure. We will describe a research project aiming to recover explosives from military refuse dumps, including such items as bombs, artillery munitions and mines, which can then be made into usable industrial explosives for use in the extraction of raw materials, in particular in opencast mining.

3.45 – 4.00 p.m.

Volodymyr I. Bondarenko, Volodymyr S. Falshtynskiy, Roman O. Dychkovskiy, *National Mining University, Dnipropetrovsk, Ukraine*  
Józef Dubiński, Jan Wachowicz, *Central Mining Institute, Katowice, Poland*

**PARAMETERS OF THE TEMPERATURE DISTRIBUTION IN THE ROCKMASS CONTAINING UNDERGROUND GAS-GENERATOR**

This paper presents the results of research on the dynamic temperature field in rockmass in underground gasification of thin coal seams in different geological conditions. It discusses heat distribution and specifies blowing mix and output products according to technological parameters of gas-generator.

4.00 - 4.15 p.m.

A.N. Shabarov, N.V. Krotov, D.V. Sidorov, S.V. Tsirel, *Scientific Centre of Geomechanics and Mining Operations Problems of SPMI, Saint Petersburg, Russia*

**MODERN METHODS AND MEANS FOR SOLVING FORECAST ISSUES AND PREVENTION OF GEODYNAMIC PHENOMENA IN COLLIERIES**

The paper concerns the safety problems in underground mining, considering mainly the underground quakes problems. Authors gave the examples of the past incidents in various Russian mines. They propose the methods of forecasting such events to avoid the possible tragedies in the future.

4.15 - 4.30 p.m. Discussion and comments

4.30 - 5.00 Coffee break

5.00 - 5.15 p.m.

J. Zalewska, M. Dohnalik, G. Sikora, *Instytut Nafty i Gazu, Krakow, Poland*

**3D CHARACTERISTICS OF INTERNAL PORE STRUCTURE OF ROCK SAMPLES USING X-RAY MICROTOMOGRAPHY**

This paper shows basis of computed microtomography, short built description of microtomograph and shows how Benchtop 160 CT apparatus works. It shows first "own" results and application capabilities of this method in solving geophysical and geological problem.

5.15 - 5.30 p.m.

E. Zimmermann, C. Niemann-Delius, *Surface Mining and Drilling, Aachen University, Aachen, Germany*

**UPGRADING OF LOW RANK COALS BY MICROWAVE TREATMENT**

Low rank coals (LRC) are common domestic fossil fuels in many countries all around the world. Most of the countries utilize LRC in power plants for electricity and heat generation. Within the process of gen-



eration the coal is milled down and dried in order to achieve a cleaner and more efficient combustion. These processes including combustion can be improved by microwave treatment of LRC, since it changes the interior porosity. Based on a changed porosity the required energy for milling and drying time are reduced. Beside these benefits, there is a good possibility that a changed porosity diminishes the concentration of NO<sub>x</sub> in the flue gas. This paper shows the results of test series conducted at the Aachen University. It addresses the needed milling energy and the reduced drying time in relation to changed porosity of LRC from the easterly German lignite basin.

5.30 - 5.45 p.m.

Dimča Jenić *RTB-Bor, Serbia*, Mladen Stjepanović *Engineering Academy (JINA), Belgrade, Serbia*, Zoran Stanisavljević *GEOING, Belgrade*, Dragan Guzijan *IRMA, Belgrade*, Predrag Golubović *RTB-Bor, Serbia*, Bojan Drobnjaković *IRM-Bor, Serbia*

**THE APPLICATION OF THE NEW TECHNOLOGIES FOR THE TAILINGS DISCHARGE FROM THE OPEN PIT AND FLOTATION PLANTS OF THE COPPER MINE IN RTB-BOR, SERBIA, IN ORDER TO IMPROVE THE ENVIRONMENTAL PROTECTION**

The massive extraction and ore processing on open pits and flotation plants of the copper mine in RTB-Bor involves a traditional method for discharging of huge amounts of tailings on previously prepared locations. The traditional method for discharging of both the tailings from open pits and flotation tailings significantly increases the production costs and causes severe pollution of the environment, due to the emission of dust and degradation of huge surfaces of fertile soil and forests. Thus, the air, ground and water are subject to heavy pollution. This presentation describes the new technology for discharging the tailings from open pits by direct discharging from a significant height into the excavated areas of closed pits in Bor, accompanied by the technology of knocking down the dust during the discharging. Furthermore, the presentation describes the new technology for discharging the flotation tailings by hydro-mixture, which prevents the generation of dust from the formed flat surfaces of flotation tailings in Bor and Majdanpek.

5.45 - 6.00 p.m.

V.S. Litvinenko, I.N. Beloglazov, A.G. Afanasyev, A.I. Mikheyev, *Mining Institute, Sankt Petersburg, Russia*

**MILESTONES OF DEVELOPMENT OF THE MINING INSTITUTE**

The paper presents the history of the mining education in Soviet Union and Russia during the period of three last centuries. Authors gave the information about sorts of mining schools and education forms, which occurred in various periods of time, giving also the actual information about the current situation in this matter.

6.00 - 6.15 p.m.

Antoni Tajduś, Piotr Czaja, Andrzej Wichur *AGH University of Science and Technology, Poland*

**HIGHER EDUCATION AT AGH UNIVERSITY OF SCIENCE AND TECHNOLOGY IN KRAKOW FOR THE NEEDS OF MINING INDUSTRY**

The paper presents the education system at the AGH University of Science and Technology in Krakow in aspect of the mining sciences and potential interest of the industry. Authors gave the general information about current and past data concerning the specializations and number of graduated students.

## **SESSION 1**

*21st World Mining Congress, 7-11.09.2008, Kraków, Poland*

---

6.15 - 6.30 p.m.

E. Guclu, İ.E. Onsel, T. Hudaverdi, C. Kuzu, G. Onal, G. Okten, *Istanbul Technical University, Mining Engineering Department, Turkey*

### **THE EXPERIMENTAL PIT PROJECT OF THE FACULTY OF MINES AT ISTANBUL TECHNICAL UNIVERSITY**

The experimental pits provide practical training chance for engineering students. Similar training mines founded in Colorado School of Mines and University of Arizona (San Xavier Mine). The real or pilot equipments used in experimental pits help the students to understand the theoretical lectures easier. Experimental pit is planned under the scope of "ITU Mining Science Park Project" and the project started at the date of 14 March 2008. The excavation is expected to be finished at September 2008. The aim of the experimental pit is demonstrating the conditions of mines to visitors and students. So students would get the chance to have applied lectures in the mine. It is expected that experimental studies would service the disciplines such as mining, geology, geophysics and civil engineering so it would be multi-disciplinary study. In addition, there will be 15 small rooms in the mine to supply enough place for this service. The length of the tunnel, which is planned to be excavated, is totally 592 m. For now 95 m of the tunnel is excavated. The depth of the mine will be 20 m. 100 m of the tunnel is designed to be an underground museum and will be free for visitors. The cross-sections of the galleries are planned as 8, 10 and 14 m<sup>2</sup> in different parts of the mine. Mine will have two entrances for easier ventilation and transportation. One of them will be a straight gallery and the other one will be the shaft that was opened before the experimental pit project for metro construction. Two types of production method are planned to be demonstrated in the experimental pit. One of them is longwall mining and the other is room and pillar mining. So the students will have the opportunity to see two mining methods together at the same mine.

6.30 - 6.45 Closing Session 1

**8.00 p.m. Banquet at Auditorium Maximum Jagiellonian University, Krupnicza str., Restaurant Hall (Level -1)**

**10<sup>th</sup> September 2008**  
**Day 4 (Wednesday)**  
**GH B - B Part of Great Hall in AM**  
**of Jagiellonian University,**  
**Krupnicza str**

**Session 2 Methods of underground and open pit mining**  
**Venue: B Part of Great Hall in Auditorium Maximum**

Chairman: Partha S. Bhattacharyya, Co-Chairman: Waldemar Korzeniowski, Stefan Kukińska  
Secretary: Krzysztof Skrzypkowski

9.00 - 9.15 a.m.

S. D. Flook, J. J. Leeming, *Joy Eurasia United Kingdom*

**RECENT DEVELOPMENTS IN LONGWALL MINING ENTRY DEVELOPMENT,  
AND ROOM AND PILLAR SYSTEMS**

Recent coal price increases and high demand for coal have led to more productive longwalls, higher advance rates in developments and greater capacity equipment for room and pillar mining. The Shendong Coalfield is a good example of what can be achieved. This was a Greenfield site 10 years ago. Today it is producing over 200 million tonnes per annum and growing at a rate in excess of 10 million tonnes per annum with longwalls all achieving between 5 and 10 million tonnes per longwall per year. The largest roof supports ever made (30% more cycles than the previous biggest) and the biggest AFC's and widest faces are shortly to be installed or have had operating experience in China and Australia. New broadband conveyor chain is extending the face lengths, increasing the production limits and reducing the operating height of longwall faces. As the longwall production and productivity has increased the requirement for high-speed roadway development systems has risen. The introduction of full width miner bolters with integrated roofbolting equipment close to the extracted face is meeting these development targets. In room and pillar mining new heavier duty continuous miners equipped with 'wet head' pick face flushing systems have led to greatly reduced dust makes and increased pick life and the new updated flexible chain conveyor has brought more production and productivity records. New control technology and automation systems like the RS20s and Faceboss systems are providing better control, increased diagnostics and full automation leading to large increases in the annual rate of production. This improved management information has led to further increases in operating time and this technology has provided a link across all these new advances in modern mining equipment. As the demand for coal has increased, so the leading manufacturers and coal mine operators have continued to develop new systems and new equipment to meet the increased production and productivity demands. This increase in innovation and management control can be expected to continue in the future with larger, more productive, more reliable equipment giving ever more increases in production.

9.15 - 9.30 a.m.

M.V. Kurlenya, V.I. Klishin, B. Kubanychbek, *Institute of Mining, Siberian Branch,  
Russian Academy of Sciences, Russia*

**PRESSURE CONTROL AND TOP COAL DRAWING BY POWERED MACHINE  
COMPLEXES IN MINING AT THICK COAL SEAMS**

The paper describes the ways for the development of the technology and power-driven equipment for coal drawing from the top of thick coal seams, and presents the results of the laboratory research of various process flow charts with coal drawing to the forefront and rear of face conveyor. The authors offer a new mode of coal drawing by gravity in higher rock pressure areas above the powered support units lengthwise a longwall face from all the support units, that allows for losses to be cut down and coal

ash content to be decreased. Engineering solutions for new designs of powered supports have been proposed.

9.30 - 9.45 a.m.

P. Cicmanec, J. Hrabovski, J. Durove, *Upper Nitra Mines of Prievidza, Technical University of Kosice, Slovakia*

### **MECHANIZED MINING OF MIGHT COAL SEAMS INTO COMPLICATED GEOLOGICAL AND UNDERGROUND CONDITIONS**

A sequential development in the underground coal extraction of might coal seams into Upper Nitra Coal Basin, where the coal is from the Tertiary geologic time and genus is evaluated. In general, a coal seam over 5.5 m and up to 18.0 m thickness and the angle of seam is between horizontal and  $\pm 25^\circ$ , the strata has tectonically deformed in blocks of horsts and grabens and displaced with upthrow faults of 2.0 m up to 90.0 m. From geotechnical point of view is the coal strongest of seams, it is set between hanging and background that are three times lower to the strength of the coal seam. These conditions create the mine-intensive environment for safe and efficiency exploitation. The knowledge source based on of more as a one hundred of full mechanized coal-walls necessitated the modification of technologic methods and innovation of hydraulic steel supports with their all purpose utilization for up/down or horizontal long-wall mining process.

9.45 - 10.00 a.m.

G. Önal, F. Burat, *Istanbul Technical University, Faculty of Mines, Mineral Processing Engineering Department, Turkey*

### **BORON MINING AND PROCESSING IN TURKEY**

Boron is the Group III A (13) element in the periodic table occurs in borates and borosilicates in the earth crust and had been employed by human kind for thousands of years. Boron has more than 200 kinds of use. Turkey has 72% of the world reserves. On the other hand, the Turkish figures are 35% in production and in the trade. This paper covers a general knowledge about boron, boron mining and processing in Turkey.

10.00 - 10.15 a.m.

W. Koziol, P. Kawalec, A. Kabziński, *AGH University of Science and Technology, Poland*

### **PRODUCTION OF AGGREGATES IN EUROPEAN UNION**

Natural aggregates have many applications, especially in civil engineering and road construction sectors. Demand for aggregates grows together with development of economical level of particular countries. In the paper amount of aggregates production in European Union as the whole and in particular countries were shown. Entry principles of prognosis and prospects of aggregates production in EU were presented, indicating further growth. Additionally prognosis of aggregates production in Poland, Slovakia, Czech Republic and Hungary were shown.

10.15 - 10.30 a.m.

M. Koneshloo, *Technical University of Shahrood, Shahrood, IRAN*

### **MODELING OF THE KAOLIN DEPOSITS AND RESERVE CLASSIFICATION CHALLENGES OF CHARENTES BASIN, FRANCE**

10.30 - 11.00

Coffee break

11.00 - 11.15 a.m.

A. Meder, T. Mazurkiewicz, *KOMAG Mining Mechanization Centre, Silesian University of Technology, Poland*

### **INNOVATIVE MACHINES IN THE CONDITIONS OF SUSTAINABLE DEVELOPMENT**

An analysis of Polish coal producers' demand for mining machines and forecast till the year 2010 are presented. Some innovative mining machines and equipment, including shield supports, longwall shearers, spraying installations, rack railway systems, and dust control systems are described. A technical verification of design solutions in the aspect of ergonomics and operational safety, using the methods of virtual prototyping and laboratory testing is shown. The paper is ended with a specification of some challenges concerning a further development of mining mechanization.

11.15 - 11.30 a.m.

A. Aghajani Bazzazi, M. Osanloo, H. Soltanmohammadi, *Department of Mining Engineering Islamic Azad University, Iran*

### **LOADING-HAULAGE EQUIPMENT SELECTION IN OPEN PIT MINES BASED ON FUZZY TOPSIS METHOD**

Equipment selection in mining engineering is one of the most important decision that is affected the mine design, production planning and economic parameters in open pit mining. Mine planning engineers generally use of their intuition and experiences in decision making even though equipment selection is a complex multi person, multi-criteria decision problem. In this paper, from among multi criteria models in making complex decisions and multiple attribute models for the most preferable choice, technique for order preference by similarity to ideal solution (TOPSIS) approach has been dealt with. In real-world situation, because of incomplete or non-obtainable information, the data (attributes) are often not so deterministic, there for they usually are fuzzy-imprecise. Therefore, the aim of this paper is to extend the TOPSIS method to decision-making problems with fuzzy data. In this paper, gathering data from Sungun copper mine is used to illustrate the procedure of the proposed approach for loading-haulage equipment selection.

11.30 - 11.45 a.m.

R. Zimróz, *Wroclaw University of Technology, Poland*

### **ADAPTIVE APPROACHES FOR CONDITION MONITORING OF MINING MACHINES**

Mining machines often work under non-stationary, Time-Varying Load Conditions (TVLC). The non-stationarity of load is mainly caused by the non-stationarity of technological process of mining (variation of external load caused by an operating bucket wheel, a time-varying stream of materials transported by conveyors, etc.). Taking into account variation of external load, complex mechanical structure of diagnosed object, environmental impact, high level of internal/external interference, possibility of multi-faults appearance (in different location, development stage, nature of damage, i.e. distributed/localised, etc.) condition monitoring becomes a serious task. Indeed, diagnostics of wear, and especially of local damages (for example related to tooth crack/breakage) is complicated and unfortunately even professional diagnostics systems are sometimes not able to recognize it. In author's opinion one of possible reasons is that diagnostic systems are closed, with rigid rules of signal processing and reasoning. For example for such unique machines like bucket wheel excavator there is a need for more individual approaches. In this paper an attempt of generalization of requirements for such diagnostic system is presented. First assumption is that condition monitoring should be adaptive at signal preprocessing level, diagnostic feature extraction level and finally, at diagnostic reasoning level. As a practical results of research carried out in this field following issues will be presented: adaptive signal pre-processor (adaptive filter) for local damage detection in gearboxes and bearing (G, B), adaptive subsystem for local damage detection (G, B), adaptive subsystem of diagnostic reasoning for local damage diagnostics (G), adaptive subsystem of diagnostic reasoning for geared wheel cooperation assesment (G). It will be illustrated by examples based on industrial data captured from mining machines during normal (non-stationary) opera-

tion, namely two stage gearbox used in driving unit for belt conveyor transportation, complex gearbox with damaged planetary stage (bucket wheel excavator), bearing used in pulleys (belt conveyors).

11.45 - 12.00 a.m.

J. M. Czaplicki, *Silesian University of Technology, Poland*

### **THE ANALYSIS AND CALCULATION PROCEDURE FOR SHOVEL-TRUCK SYSTEMS WITH A CRUSHER AND CONVEYORS**

The method of analysis and calculation of shovel-truck systems was recently developed, allowing for comprehensive considerations of almost all major problems connected with this type of machinery system. One possible modification to the system is the application of an in-pit mobile or movable crusher and conveyors ensuring further broken ore flow. Such a system is a combined cyclic and continuous one. In this paper the procedure of modelling, analysis and calculation of this type of system is presented together with the vast orientation of stochastic problems associated with the system exploitation process. Following the considerations, some conclusions are drawn and some vital remarks made.

12.00 - 12.15 p.m.

W. Kawalec, *Institute of Mining Engineering, Wrocław University of Technology, Poland*

### **MODELING OF TRANSPORTATION COSTS FOR ALTERNATIVE LIFE-OF-MINE PLANS OF CONTINUOUS SURFACE LIGNITE MINES**

The financial analysis of a Life-Of-Mine plan of an optimised open pit depends on accuracy of its deposit economic model. The price formula of lignite can be built of its quality parameters and energy market analysis but mining costs depend on a mining system. Once the ultimate pit size and its annual output are set the alternative pit advancing with suitable conveying system can generate locally various mining costs. Modelling the distribution of these costs in an economic block model of a lignite deposit and their influence on mine's cash flow over its lifetime have been presented.

12.15 - 12.30 p.m. **POSTER**

W. Batko, A. Mikulski, W. Cioch, *AGH University of Science and Technology, Poland*

### **THE NEW METHOD DIAGNOSTICS OF STEELWORK IN PIT SHAFT**

This article presents a new testing method allowing for expeditious recognizing of the condition of elements of the entire shaft and selecting the most worn-out elements, which can be subsequently subject to more detailed examination. For the purpose of evaluating the technical state in a short time and at the same time securing the reliable results, new examination procedures were formed, helpful in detection and localization of damages in the elements of mining-shaft reinforcement. The essence of this method is examining the dynamic properties of a structure with the application of pulse test that involves exciting vibrations in the structure and measuring excitation response. The procedures relate to modal experiments, supplementing contained in those experiments procedures of signal processing with algorithms of wavelet expansion. This solution extended the possibilities of pulse-test applications and generated new carriers of information on the state of diagnosed elements. Starting point is the assumption that in the moment of damage occurring in the structure, basic dynamic parameters (e.g. damping) change. Mathematical tools hinge on simultaneous signal processing in time and frequency domains. It involves signal analysis with the application of Fourier transform of wavelet function. The analysis was implemented in designing and constructing of portable microprocessor-based measurement system dedicated to non-stationary signal analysis. Diagnostical device constructed with the application of most recent electronic technologies is fitted with control keys and LCD display. It was programmed with consideration of diagnosing guiding-rails for mining-shaft lifts, using pulse test methods. Time-consuming operations of signal processing were executed in reprogrammable FPGA systems. Verification of the developed method of examining shaft reinforcement was conducted on one of the mining-shafts at Copper Mining & Metallurgy Complex „Polska Miedz” in Polkowice. Results of conducted examinations of over 80 guiding rails of different wear-state are discussed in the article.

12.30 - 12.45 p.m.

V. G. Chervatyuk, V.V. Vasilyev, V. V. Buzylo, I.A. Kovalevska, *SC Pavlograd-vugilla, Ukraine*

**THE MODERN ASPECTS OF THE ANCHOR FASTENING USE IN THE ENVIRONMENT OF SC PAVLOGRADVUGILLA**

The main principles of underground mine workings maintenance by alternative technologies by the mean of edge rock hardening and the involvement of these technologies to counteract mine pressure are formulated.

1.00 - 3.00 p.m.

Lunch

3.00 - 3.15 p.m.

S.V. Muchnik, V.N. Oparin, *Institute Of Mining, Siberian Branch, Russian Academy Of Sciences, Russia*

**EXPERIENCE AND PROSPECTS OF TURBO-BLASTING AT OPEN-PIT MINES**

The highlight of the paper is the potentiality of resource conservation and mitigation of ecological impact after blasting at open pit mines by application of the forced convection of detonation products in a hole. It is expounded how to drive the forced convection of gas-dispersion detonation products, as well as a convector and the designs of various charges to be used in the open pitmining are described. The prime elements of the turboblasting technology are described, and its case history is presented, backed by the actual data on the existent resource-saving and nature-oriented pay-off of the technology application at ore and nonmetallic quarries and coal open pits in Russia.

3.15 - 3.30 p.m.

Z. Zhiyu , L. Longfa, Y. Zhiqiang , M. Yangang, *Kunming University of Science and Technology, China*

**EXPERIMENTAL STUDY FOR IMPROVING THE BLASTING EFFECTS OF BAIDENG PHOSPHORUS OPENCUT BY INITIATION IN BOREHOLE SEQUENCE**

The practice tests of ignition in borehole sequence by high-precision net detonator in the opencut had been achieved. The analysis had be done about the mechanism of the technology, the design of blasting net, increasing shoveling efficiency reducing the blasting vibration and boulder frequency and blasting cost, and the advantages of such technology were presented. Finally an effective method was taken to improving blasting impression and mining efficiency.

3.30 - 3.45 p.m.

R. Mikhelson, S. Khomeriki, D. Khomeriki, K. Dzebisashvili, H. Tudeszki, S. Rossbach, *L.P.P.L.G. Tsulukidze Mining Institute, Georgia*

**THE COMPUTER PROGRAM OF DESIGNING DRILLING AND BLASTING OPERATIONS IN OPEN-CAST MINE**

The program of designing drilling and blasting works on open cast mines is developed with the purpose of calculation of boreholes of charges of loosening and elements of their arrangement in the blown up block, including such parameters, as resistance on a bench bottom, the sizes of a cell of a grid of boreholes, weight of a charge in a borehole, a design of a charge depending on its degree of watering, an interval of delay between explosions of numbers of boreholes.

3.45 - 4.00 p.m.

P. K. Singh, M. P. Roy, A. Sinha, *Central Institute of Mining & Fuel Research, India*  
**STUDY ON THE IMPACT OF OPENCAST BLASTING ON SURROUNDING  
STRUCTURES IN ENVIRONMENTALLY SENSITIVE AREAS**

The measured response of residential structures is a critical indicator of troublesome or potentially damaging ground vibrations. A study was conducted to evaluate the response of structures in environmentally sensitive areas in the proximity of four open-pit coal mines in India. The study involved 215 blasts, employing one-, two- and three-hole calibration study, and production blasts. The bench height varied from 7.5 m to 42 m, and boreholes loaded with emulsion and slurry explosives were 250, 260, 270 and 310 mm in diameter. The explosive detonated in a blast were between 300–198400 kg whereas in a delay it was 33–24800 kg. Eight to ten tri-axial vibration sensors were deployed along a linear array from 25 m to 6.5 km, to investigate the changes in amplitude, frequency, and duration with distance. Altogether, 1512 blast vibration signatures were recorded. The fundamental frequency of the structures ranged between 3.13 to 10.6 Hz. The blast wave frequencies at far-off distances were also in the range of the fundamental frequency of the structures. The amplification of vibration in the structures of the factor of 1.6 to 5.62 was recorded. The persistence of vibrations in the structures were upto 15 seconds. It is confirmed that if a structure is exposed to ground vibrations near its fundamental frequency, the structure will amplify the vibration level. Ground vibrations below the fundamental frequency of the structure will cause the structure to vibrate at least as much as that of the ground. It also appears that the underlying geological conditions are the controlling factor in terms of amplitude and frequency of vibration rather than the delay interval assigned between successive detonations.

4.00 - 4.15 p.m.

A. Softic, Z. Basic, A. Brigic, E. Lacic, *Brown Coal Mining Company Banovici, Bosnia and Herzegovina*  
**DECREASE OF BLASTING SEISMIC EFFECTS ON OPEN PITS IN COAL MINE  
„BANOVICI”**

Due to blasting of waste-rock, a higher intensity quakes happen. It has been chosen the most suitable explosives and optimal blasting parameters on open pit. A very small part of blasting energy is turned into kinetic energy of lower intensity seismic waves. In the future, it is necessary to impose the emulsion explosives for better blasting effects, that is, better utilization of explosives' energy.

4.15 - 4.30 p.m.

T. Kurakami, J. Yamatomi, R. Sato, Y. Sagawa, S. Murakami, *Sumitomo Metal Mining Co. Ltd., Japan*

**MINING WITH BACKFILL AT THE HISHIKARI MINE, JAPAN**

The Hishikari Mine, the only gold mine in Japan, consists of epithermal vein type Au-Ag deposits. In 2007, the mine produced 183,000 tonnes of ore, with gold grade of 46 g/t. The veins are extracted mainly by drifting and bench stoping with backfill. Blasted waste rocks are generally used as backfill materials and crushed waste rocks with cement are used for larger stopes. Backfilling controls the displacement of excavation surface and increases the stope stability, but practical evaluation for stope dimension in conjunction with backfilling effects is not established yet. So the paper presents an approach to estimate supporting effects of backfilling by using numerical analyses. The results show remarkable effects on the stope stability with more compaction and stiffening of the backfill.

4.30 - 5.00

Coffee break



5.00 - 5.15 p.m.

W. Fang-Han, Y. Zhong-Liang, C. Wei-Qin, *Changsha Institute of Mining Research, China*

### **THEORY OF AND PRACTICE IN CEMENTED FILLING WITH UNCLASSIFIED TAILINGS STRUCTURE FLUID**

With a further understanding of mineral resources not to be regenerated and an increasingly strictness of requirements for environment protection, unclassified tailings filling has found wider and wider application in metals mines. The author describes present situation of unclassified tailings filling in China and other countries, puts forward filling method for unclassified tailings structure fluid, carries out determination of rheology parameters of unclassified tailings structure fluid and theoretical analysis and calculation of transport property based on lab experiments, and makes an introduction to technological flow-chart and operation results of this filling method in combination with practice in mine fill.

5.15 - 5.30 p.m.

X. Li, Z. Zhou, G. Zhao, Z. Liu, Y. Azimi, S.H. Khoshrou, M. Osanloo, K. Shahriar, *School of Resources And Safety Engineering, Central South University, China*

### **UTILIZATION OF PHOSPHOGYPSUM FOR BACKFILLING, WAY TO RELIEVE ITS ENVIRONMENTAL IMPACT**

Intensive mining and ore processing activities concerning phosphate ores have generated billions of tons of phosphogypsum (PG) throughout world. Even in China, it is estimated that more than 200 million tons of PG waste have been disposed at tailing dumps which distributed in almost every provinces. And the amount will increase by 20 million tons annually. However, there is still little usage of them. They are just stockpiled in waste repositories. Under the action of several physicochemical mechanisms, toxic and radioactive elements contained in the wastes are mobilized, migrate to the surroundings and cause severe and widespread contamination to air, soils, surface and ground waters. This has sparked criticism from citizens concerned, and leads to high cost of treatment and compensation each year. In this paper, pilot study was conducted to improve the PG as backfilling material by adding fly ash and cement in Kaiyang Phosphorus Mine. Specimens with different blending ratio of the three compounds were tested with INSTRON testing system to obtain the best blending ratio, with which the compounding PG had the needed strength for underground backfilling. Then, the corresponding filling system was developed to transmit the backfilling material into stopes. By this way, 100,000 tons of PG was changed from waste into valuable backfilling material annually. Two years' application and monitoring prove that utilization of PG for backfilling is one of the most promising ways to relieve the environmental impact of PG tailing and bring its role into play to the maximum extent.

5.30 - 5.45 p.m.

M. Yumlu, *AMC Consultants Pty Ltd., Australia*

### **BARRICADE PRESSURE MONITORING IN PASTE BACKFILL**

Despite being a mature and well proven technology, the early age behaviour of placed paste fill and the mechanism of pressure development within paste fill and the resultant loads acting on the barricades are not well understood. Mine operators usually borrow barricade designs and fill placement procedures from other mines without due consideration to their particular circumstances. Consequently, barricade failures continue to be reported in paste fill operations around the world. Safe and efficient placement of paste fill requires a detailed understanding of paste fill characteristics from the production stage to the final fill exposures. This paper presents details of a field instrumentation and monitoring program to ascertain the paste fill pressure loads acting on the barricades and to understand the pressure development mechanism within paste fill mass.

8.00 p.m.

**Banquet at Auditorium Maximum Jagiellonian University, Krupnicza str., Restaurant Hall (Level -1)**

10<sup>th</sup> September 2008  
Day 4 (Wednesday)  
Small Hall / Middle Hall: Part- B  
Auditorium Maximum of Jagiellonian University,  
Krupnicza str

**Session 3: UNDERGROUND MINE ENVIRONMENT**

**Part 3.3: VENTILATION & MINE FIRES**

Venue: Small Hall Auditorium Maximum

Chairman: R.N. SINGH, Co-Chairman: Stanisław WASILEWSKI,  
Secretary: Marek BOROWSKI, Dariusz OBRACAJ

11.00 -11.10 a.m.

Henryk BYSTROŃ, *Central Mining Institute, Poland*

**THE THERMODYNAMIC APPROACH TO THE SAFETY STATE ASSESSMENT OF A VENTILATION SYSTEM OF A DEEP MINE USING UNDERGROUND MAIN FAN**

The mine air has been treated as pure dry air and its turbulent flows – as one-dimensional steady flows with heat exchange. The input and output values have been determined. A two-mesh canonical diagram of the ventilation system of a deep mine has been drawn up. Basing on mentioned output values two mesh equations have been written. Starting from these equations a thermodynamic condition / safety degree has been derived. For the case of gravimetric approach making use of known adequate elevations above datum, aerodynamic resistances of branches and specific volumes, using known formulas the aerodynamic resistances of resultant branches as well as the main fan pressure, the natural pressure acting in the entire system and gravimetric safety degree have been calculated. According to the analysis of obtained results the assumed aim has been achieved as well this work should be treated as a supplement to the Czeczott's one concerning underground fans danger.

11.10 - 11.20 a.m.

Nikodem Szlązak, Dariusz Obracaj, Marek Borowski, *AGH University of Science and Technology, Poland*

**METHODS FOR CONTROLLING TEMPERATURE HAZARD IN POLISH COAL MINES**

Polish underground coal mining is facing more and more difficult climatic conditions at work places every year. In the nearest future these conditions may be expected to get even worse as mining is started at deeper levels and is even more concentrated. This article discusses present climatic conditions in Polish coal mines. The sources of heat load and ways of heat transfer into excavations are discussed. The methods for improving thermal conditions are characterized as well as their ineffectiveness in mines with a great temperature hazard. The methods of air conditioning in underground mines are characterized. The examples of refrigeration and air conditioning systems in Polish mines are presented. Advantages and disadvantages of these systems in Polish mining conditions are given. The directions in which airconditioning may head towards are determined on the basis of air conditioning systems that are being implemented at the moment.

11.20 - 11.30 a.m.

Stanisław Wasilewski, *AGH University of Science and Technology, Poland*

**DEVELOPMENT OF GAS HAZARD MONITORING SYSTEMS IN POLISH HARD COAL MINES**

The paper presents briefly the history of automatic gas monitoring systems in Polish coal mines. The changeable mining and geological conditions, as well as systems of the exploitation generate new categories of hazards. These new threats demand new devices and new criteria in hazard monitoring

systems. It characterizes the present development stage of monitoring and control systems, including measurements of environmental parameters, transmission and data visualization, alarm state warning, automatic emergency energy switch-off and using methane monitoring for blocking machines and technological devices in case of gas explosion hazards. The new solutions, which have recently been put in use, allow gas monitoring systems to integrate functions of alarms and warning in case of hazards and support operator to evacuate miners from dangerous zones. At the end of the paper there are some examples given, determining the directions of development of automatic gasometry using the most advanced technologies within metrology and telecommunication.

11.30 - 11.40 a.m.

Władysław Cierniak, Waław Dzierżyński, Andrzej Krach, Janusz Krawczyk  
*Instytut Mechaniki Górotworu PAN, Poland*

#### **DISTRIBUTION OF VELOCITY OF FLOW OF AIR IN THE INLET CHANNEL OF A MAIN FAN**

A method of a continuous measurement of an unsteady distribution of velocity in a cross section of a mine working has been presented. The measurement was made with a computer controlled portable data acquisition system with a fast 24-channel data logger capable of simultaneous sampling in all channels and in-home designed and manufactured Pitot-Prandtl tubes as fast point sensors of velocity of the turbulent flow of air and a signal conditioning module. As the site of experiment a channel of a main ventilation fan of Janina colliery was selected. The paper contains a description of the system and an example of measurement results.

11.40 - 11.50 a.m.

Janusz Kruczkowski, *Instytut Mechaniki Górotworu PAN, Poland*

#### **A SYSTEM FOR CONTINUOUS MEASUREMENT OF VOLUMETRIC RATE OF UNSTEADY FLOW OF AIR IN WORKINGS OF DEEP MINES**

The process of measuring unsteady air flow in a deep mine's working is a difficult and complicated measuring issue, not solved satisfactory so far. The paper concerns a system for air flow velocity measuring by the method of velocity field, based on integrating the velocity on working's cross-section. Application of multiple anemometrical sensors, sampling velocity in selected points of working's cross-section, together with wireless transmission of measurement data to a computer unit (recording the data and processing them in real time), allow us to estimate the instantaneous distribution of air flow velocity in the section and calculate the instantaneous value of volume flow. Among estimation methods, one can find linear triangulation method, where the cross-section of the working is divided into triangular areas in such way that vertices of the triangles are the points where the velocity either is known from conducted measurements or calculations or it is assumed. Additionally, points on the edges are introduced to comply velocity distribution by working's walls if there is no possibility of locating sensors there. The system is a mobile facility, capable for easy transport throughout the mine. Thus, the support construction for the sensors was designed in a way providing its fast assembling and disassembling. The article presents exemplar results of velocity measurement records, further used for calculating and visualizing the volume flow. It was shown how to obtain information on spatial parameters of sensors' localizations as well as on working's cross-section by using photogrammetric method with the appliance of digital photography method. The system is presumed for precise verification of unsteady volume flow, as well as for scientific and cognition researches over unsteady flow phenomena and velocity fields in severe environmental conditions, such as deep mines' workings and tunnels.

11.50 - 12.00 a.m.

Józef Sułkowski, Dariusz Musioł, *Politechnika Śląska, Poland*

#### **EFFECT OF BED SPLITTING ON FIGHTING AEROLOGIC HAZARDS IN EXPLOITATION SECTIONS OF HARD COAL MINES**

Ever broadening functions of process headings, related to the longwall with caving in hard coal mines, include also fighting fire, methane and climatic hazards, called aerologic hazards. Therefore, planning of the process headings is necessary to be conducted so that the created ventilation system of the exploi-

tation section performed as best as possible as regards safety. Meeting these functions will depend on the structure of the drawing and process heading network originated during splitting of the exploitation field. The paper analyses the structure of ventilation networks created with various models of bed splitting and evaluates the related ventilation systems of exploitation sections in terms of safety.

12.00 - 12.10 p.m.

Ran Vijay Kumar Singh, Durga Dutt Tripathi, Virendra Kimar Singh, *Central Institute of Mining & Fuel Research, India*

### **EVALUATION OF SUITABLE TECHNOLOGY FOR PREVENTION AND CONTROL OF SPONTANEOUS HEATING/FIRE IN COAL MINES**

The problem of spontaneous heating/fire in coal mines is very serious and needs immediate attention. A mine fire is not only dangerous to the workers employed in the mine, but it also results in heavy loss of valuable coal, a national asset being the primary source of energy. Most of the fires in different coal-fields originated from many decades ago in collapsed workings of thick seams, at shallow depth. Where the workings were at shallow depths and the extracted seam thickness were high subsidence cracks appeared on the surface providing a path of the air flow to the fire zone. In this way many underground fires turned to surface fires at a later stage. If exposed coal benches of the opencast mines are left idle for longer times i.e. beyond its incubation period, then due to the intrinsic properties of coal, oxidation takes place and it catches fire. Besides this, there are several incidences of fire originating from quarry edges due to dumping of hot ash and illicit distillation in abandoned workings near quarry edges. There are different technologies available in the different parts of the world for prevention and control of fire such as surface sealing, trench cutting, flooding, filling of incombustible material, inertisation (Nitrogen and carbon dioxide), fire protective coating, grouting and application of chemical inhibitors. All technologies cannot apply everywhere. The application of technology for prevention & control of fire will vary case-to-case and site-to-site basis. After application of these technologies, we are getting good results for prevention and control of fire. But time has come to evaluate the suitable technology for prevention and control of fire in underground and surface coal mines. Firstly the situation of fire should be studied in detail and secondly the suitable technology should be selected as per site-specific condition and applied. The technology should be economical and suitable for the existing situation of fire. The objective of the paper is to describe the different situation of fire and evaluation of suitable technology for prevention and control of spontaneous heating/fire in coal mines.

12.10 - 12.20 p.m.

Wu Chao, Li Zijun, Yang Fuqiang, Gu Desheng, *School of Resources and Safety Engineering, National Research Center of Safety Science and Technology for Metal Mines, Central South University, China*

### **RISK FORECAST OF SPONTANEOUS COMBUSTION OF SULFIDE ORE DUMP IN A STOPE AND CONTROLLING APPROACHES OF THE FIRE**

In this paper, a set of reliable devices and flowchart used for testing the potential of spontaneous combustion of sulfide ores (SOSC) are presented. An effective assessment method which depends upon the fire index system for evaluating the risk of SOSC in a mining stope is introduced. To get more detailed information on self-heating situation in the ore dump at various period, the surface temperature on the ore dump is measured by an infra image apparatus and the temperature in the ore dump is analyzed both by ANSYS and FLUENT software. These results are visual and effective for applying correct measures for preventing the fire-breeding. Also, a group of chemical agents for abating the oxidized velocity are invented and can be sprayed into the ore dump. By integrating with all technical approaches described in above and using them for dealing with various practical conditions, the risk of SOSC in a stope can be effectively controlled.

12.20 - 12.40 p.m.

Borys Poborowski, Lachlan Cunningham, *Solid Energy North, New Zealand*  
**MANAGING THE SPONTANEOUS COMBUSTION HAZARD IN SUB-BITUMINOUS UNDERGROUND COAL MINE**

Testing and analysis of New Zealand's sub-bituminous coals has highlighted a characteristic of very high to extreme inherent propensity for spontaneous combustibility. A number of geological, geotechnical and operational factors specific to Huntly East Mine further aggravate the risks associated with self heating. In the past the colliery relied on natural inertisation to control the spontaneous combustion hazard in sealed areas. This process was dependent on using the natural desorption of seam methane to develop a fuel rich, but oxygen deficient atmosphere. Following a serious goaf heating resulting in an organised mine evacuation, some significant changes were introduced to the site spontaneous combustion management system. The concept of nitrogen injection, as a method of rapidly inducing oxygen depletion in newly sealed areas, was trialed. Encouraging results from the trial led to further operational use of the technique and resulted in the decision being made to establish a permanent site based nitrogen facility. This paper presents the additional measures taken by Huntly East Mine, from a mine design, operational process control and gas management perspective, to enhance safety procedures and minimize the risks imposed by the specific characteristics of this coal and its extreme propensity to spontaneously combust. Further, a comparison is made between the gas ratios and trends, from the mine's tube bundle gas monitoring system and gas chromatograph analysis, under normal operating conditions and during the goaf self heating incident. The results of the nitrogen injection trial are used to illustrate the proof positive of a simple, efficient and cost effective means of improving safety through the proactive management of the goaf atmosphere. The influence of the nitrogen injection into the goaf is most graphically displayed in the time resolved graphs and Ellicott's diagrams.

12.40 - 12.50 p.m.

Tomasz Grychowski, *Silesian University of Technology, Poland*  
**HAZARD ASSESSMENT BASED ON FUZZY LOGIC**

This article presents utilization of fuzzy logic and its inference mechanisms to improve reliability in a decision making process and hazard identification in monitoring a coalmine atmosphere. These proposed new solutions are based on quality analyses of measured data, knowledge of the dispatcher, as well as subjective interpretation of measurements for hazard assessment. This article presents an example of automatic hazard assessment by monitoring fire and ventilation hazards.

12.50 - 1.00 Discussion and comments

1.00 - 3.00 Lunch

**BLOK 3.2: GROUND CONTROL AND ROCK BURSTS**  
**Venue: Small Hall**

Chairman: Ray DURRHEIM, Co- Chairman: Zenon PILECKI  
Secretary: Jerzy KŁOSIŃSKI

3.00 - 3.25 p.m.

Anatoly A. Kozyrev, Victor I. Panin, Yuliya V. Fedotova, *Mining Institute KSC RAS, Apatity, Russia*

**THE GEODYNAMIC EVOLUTION OF THE GEOLOGICAL MEDIUM IN THE AREA OF LARGE-SCALE MINING**

The result of the geological medium geodynamic regime evolution in the area of largescale mining is man-made seismic activity. Mining-induced seismicity is actual for many regions of the world where mining sector is developed. Though this problem has been already studied for so long period of time, no generally accepted classification of dynamic events occurring in mines has been generated yet, and

quite often the same events are identified by different terms. In the paper a model of the geological medium geodynamic evolution hosting the mine-natureengineering system is proposed. Indicators of the critical state of the geological medium are shown. The assessment of risks from dynamic manifestations makes it possible to have a more substantiated approach to the solution of prediction and prevention tasks, since they are costly measures. The size of risk can vary within a wide range, while the level of its importance for the company is determined by the scale of production and the current technical and economic conjuncture. However, it is certain, that the value of human life has not only the money equivalent, so the labour safety issues at any mine are of top priority. The paper relates to the ways how to predict and prevent rockbursts and mining-induced earthquakes. When planning the strategies of prediction and prevention of critical states of natural-engineering system (mining-induced catastrophes) one has, first of all, to make certain of what is the concept and what kinds of catastrophes are typical during the development of deposits in highly stressed rock masses. The combination of the correct determination of the physical nature of the expected kinds of rock pressure manifestations and consideration of the function and size of the working and presence of people and mechanisms in it will allow to make the most rational and economical choice of preventive measures.

3.25 - 3.40 p.m.

Grzegorz Mutke, *Central Mining Institute, Poland*

#### **STABILITY OF THE UNDERGROUND MINE WORKINGS IN THE NEAR-FIELD ZONE OF SEISMIC EVENTS**

The performed analysis of the damaging effects in a mine working caused by mine tremors from the Upper Silesian Coal Basin clearly shows, that they only occur when the tremor sources are located close to the opening (mostly up to 100 m). In the near-field wave motion, the PPV (peak particle velocity) parameter reaches high values. Seismic underground measurements in Polish coal mines have shown that the near-field PPV may exceed a value of 1,0 m/s and the peak particle acceleration may exceed a value of 5g. As it is known, the PPV is proportional to the value of dynamic stresses  $\Delta p_d$ . In the near-field the dynamic stress increment can reach 10 MPa or even more at the walls of an excavation and supports. The scaling law related seismic moment, peak particle velocity amplitudes (PPV) and distance to the event have been found based on the data from Polish mines:  $\log(\text{PPV} \cdot R) = 0,66 \cdot \log(M_0) - 7,4$ ; where:  $M_0$  – seismic moment,  $R$  – hypocentral distance. An empirical criterion for potential rockburst hazard has been developed based on the worked out relationship. The scaling law has been established to estimate seismic damage based on dynamic stress increment. The above mentioned criterion has been verified in the way of analysing the documented database of 120 rockbursts with damaging effects in mine workings, occurred in the Upper Silesian Coal Basin from 1988 to 2006. It was found, using a relationship between  $R \cdot \text{PPV}$  and  $M_0$ , that 90% of the rock bursts occurred in the area where peak particle velocity (PPV) reached values ranging from 0.05 m/s to 1 m/s. Using scaling law and location of seismic events, it is possible to find hazardous areas in the mine. The investigation results presented in this paper may be used in both the spatial-temporary planning of mining operations under predicted high seismicity conditions and the rational choice of support and preventive actions ensuring functionality of mine workings and improvement in work safety level.

3.40 -3.55 p.m.

Augustyn Holeksa, Mieczysław Lubryka, Ryszard Skatuła, Zbigniew Szreder, „JAS-MOS” COAL MINE, *Poland*

#### **EXPLOITATION OF DEPOSIT 510/1 THROUGH LONGWALL 22A IN LOT Z3 AT "JAS-MOS" COAL MINE IN THE CONDITIONS OF SIGNIFICANT SEISMIC ACTIVITY JAS-MOS COAL MINE JSW S.A.**

The article, the paper presents an example of the coal wall exploitation accompanied by great seismic activity, mainly connected with presence of the edge of superstructure and the neighbourhood of the dodge zone. It presents the applied monitoring system for the rockburst threat and an active rockburst prevention.

3.55 – 4.10 p.m.

G.I. Grutsko, *Russian Academy Sciences, Russia*

### **MULTIDISCIPLINARY APPROACHES IN RESEARCHES OF METHANE OUTBURSTS AND EXPLOSIONS IN COAL MINES**

In process of the depletion of stocks of oil and gas, the of coal use will increase. Its competitiveness will depend on safety of coal output. During re-structuring of the coal industry of Russia dangerous coal mines has been closed. Gas-dynamic displays continue to remain factors of danger of mining. Their realization is the reason of competitiveness of coal. A row of the geomechanical and gas-dynamic displays (such as gas emission, sudden outbursts of coal and gas, explosions of methane and coal dust, mountain bumps, rock failures, mine fires, water intrushes) is already impossible to explain, prognosis and prevent in the former frameworks of "classical" geomechanics, without the use of modern multidisciplinary approaches, methods of instrumentation, the results reached by modern fundamental sciences. Given in the appendix the cases of sudden outbursts of coal and gas in Kuzbass are considered. The researches of displays of gas dynamics of in connection with the zoning of geological gas migration in bowels are investigated. It is claimed about the geological readiness, modern geological processes of "additional charging" by migratory gases of terrestrial bowels dangerous in outbursts of tectonic structures. Geological conditions, spatial and temporal inequality of the migratory gas saturation create dangerous situations of sudden outbursts of coal, rock and gases, gas emission on the surface. Genesis of the development of outbursts of methane (possibly the accompanying hydrogen as well) into explosions of gases and a coal dust can have not only the technological reasons, but also the reasons of geology structural and geomechanical character, especially in view of possible presence nanoelements in coal. Such researches allow to find methods of influence on a coal-bed for the prevention of explosions.

4.10 - 4.30 p.m.

Małgorzata Wysocka, Krystian Skubacz, Bogusław Michalik, Stanisław Chałupnik, *Central Mining Institute, Poland*

### **RADIATION PROTECTION IN POLISH COAL MINES - SYSTEM OF MONITORING AND CONTROL OF THE HAZARD**

The radiation risk due to the exposure to natural radionuclides, especially to short-lived radon progeny, is a component of the radiation hazard, common in the natural environment and working environment of people. The effective dose, caused by the exposure to radon (radon progeny), exceeds 50% of the average dose for a man from all sources of the ionising radiation. Under specific circumstances, for example as a result of working in confined space with low ventilation rate (cellars, underground galleries, tunnels, mines), the risk caused by radon and its progeny can be enhanced and can reach significant levels. In Polish mining industry the radiation hazard, caused by natural radionuclides is one among many other natural hazards. It is worth to be point out that besides radon another source of radiation hazard in coal mines is radium, present in underground brines. Sediments, precipitated out from such waters, have enhanced radium content and may cause the increase of external gamma radiation dose rate as well as internal contamination due to accidental ingestion or inhalation. Investigation of that specific problem has been started in hard coal underground mines in Poland in early 1970's. At the end of 1980's first regulations were issued: the national standard have been prepared, in which dose limits and requirements of the radiation monitoring have been established. In following years in some branches of underground mining (mainly in coal mining industry) internal regulations for monitoring and mitigation measures were developed on the basis of the Polish standard. Due to being in force regulatory acts - Geological and Mining Law, Decree of the President of State Mining Authority and Decree of the Ministry of Economy – the monitoring and prevention against natural radiation is obligatory in all Polish underground mines since 1989. This duty is strictly supervised by local offices of State Mining Authority in co-operation with other governmental agencies. Monitoring and mitigation measures are obligatory not only for active mines but also for mines, excluded from the exploitation, and used for other purposes as museums, balneotherapy spas etc. Such solution is unique in non-uranium mining.

4.30 - 5.00 p.m. Coffee break

**Blok 3.4: Work Safety in Mining  
Venue: Small Hall**

Chairman: Shanti K. CHOWDHARY, Co- Chairman: Kazimierz LEBECKI  
Secretary: Mariusz KAPUSTA

5.00 - 5.10 p.m.

Yibo WANG, *North China Institute of Science and Technology, China University of Mining & Technology, China*

**WILD APPLICATION OF NONLINEAR SCIENCE WILL BE IMPORTANT ASPECT IN DEVELOPMENT OF COAL MINE TECHNOLOGY**

Because of the differences of geological conditions, the production of coal mines is induplicable and the safety problems of coal mines are different, so current unitive general mine safety technology can not get same effect in different mines. Under such condition, it is quite urgent to develop new unitive technology for safety production of coal mines. This article expatiated on the important functions of non-linear science in safety production of coal mines by successful application examples of following aspects: prediction of coal and gas burst, prediction of gas preservation law, and calculation of gas drainage time, etc. In a word, to generalize the application of non-linear science in coal production will improve the safety conditions of coal mine production.

5.10 - 5.20 p.m.

M. Baginski, *Central Mines Rescue Station, Poland*

**AUTONOMOUS RESPIRATORY PROTECTION EQUIPMENT VS. PROVISION OF MINING RESCUE SERVICES, PROTECTIVE EMERGENCY ESCAPE DEVICE -QUALITY AND EFFICIENCY**

The provision of mining rescuers with regenerative and cylinder-based breathing apparatuses, together with the projection of prospects for the development of the apparatus design and provision of the rescuers in the future have been described. A statement has been formulated that all new regenerative apparatuses are larger and heavier than the previous generation equipment currently used in rescue operations. To ensure compliance with the standards harmonised with the EU directives, regenerative apparatuses have been created in which the breathing comfort has been improved, yet their usability has been compromised by increasing the weight and overall dimensions. Also, proposals of an alternative solution regarding the provision of mining rescue services in the subject scope have been presented. The description presented includes also a brief comparison of operating qualities of the respiratory protection equipment discussed in the paper, when used for rescue operations. Underground deposit mining carried out in mining plants is a complex process which must take into consideration continuous care over the safety of both the employees and the company property. This form of mining entails natural threats and also additional threats resulting from high concentration of machines and devices as well as human factor. This makes it necessary to ensure a proper level of safety for both the employees and the possessed resources; each mining enterprise is subject to strict rules of work organisation and its element - OSH regulations. In connection with the above one of the elements of protection required from mining plants is the obligation to have organised rescue teams. These teams throughout the time are ready to help and use appropriate specialist rescue equipment which guarantees the safety and effectiveness of rescue operations. An important element of this equipment is self-contained respiratory system protection equipment, enabling rescue works to be performed wherever the atmosphere does not allow breathing. The majority of this kind of equipment which was used in the past and is applied nowadays includes regeneration respirators (commonly referred to as "oxygen" respirators), which work in a closed-circuit system, with oxygen compressed in an oxygen cylinder. Below have been given examples of regeneration respirator constructions. All of the presented regenerating respirators are based on a similar functional assumption, i.e. in the conditions of full isolation from the environment they absorb carbon dioxide contained in the air exhaled by the user into the respirator and provide oxygen to the apparatus breathing system, enriching the air inhaled by the respirator user. Standard parts of respirators, which come in contact with the air exhaled by the user include: facepiece or mouthpiece,



breathing hoses, carbon dioxide absorbent as well as a breathing bag. Oxygen may be stored in the apparatus in a solid, liquid or gaseous form. The following are most frequently used as carbon dioxide sorbents: lithium hydroxide (LiOH), calcium hydroxide (CaOH), sodium hydroxide (NaOH) or their mixture filling a specially prepared chamber. The process of carbon dioxide absorption by sorbent.

5.20 - 5.30 p.m.

J. Pukkila, P. Särkkä, *Helsinki University of Technology, Espoo, Finland*

### **RISK ASSESSMENT IN UNDERGROUND MINES**

This paper concerns risk assessment and safety analysis for underground work in several mines. It was implemented by the Laboratory of Rock Engineering of the Helsinki University of Technology (HUT). The sites assessed in this work were the Pyhäsalmi Mine of Inmet Mining Corporation, the Tytyri Mine of Nordkalk Oyj Abp, Orivesi Mine of Dragon Mining Limited, and the Onkalo site of Posiva Oy, an underground rock characterisation facility for final disposal of nuclear fuel. The objectives of this work were to improve the work safety of workers and the sites as well as to gain better knowledge of the hazards in underground mining and excavation processes. To attain these objectives the previously used "Risk Assessment at Workplace" method was developed to be more suitable in assessing the risks of underground mining work. The first phase of risk assessment, hazard identification, was carried out in a way where workers themselves identified risks in their own work. In the second phase, risks were shaped and their magnitudes were defined for the most often identified hazards by two parameters – probability and consequences. Proposals for actions to either reduce the magnitudes or to eliminate the risk were developed in meetings with the representatives of the company management, industrial safety organization, occupation health care and workers themselves as well as the risk assessment team of HUT. The risk levels at workplace define the need of renewing risk evaluation. Regularly done evaluation fits better to other work places than to workplaces where changes take place irregularly. Most important in occupational safety and health at all work places is sufficient contribution and continuance in risk management. The feedback to the workers has to be relevant. This way all personnel will see the importance of risk management to their own work and can have positive influence to the work safety.

5.30 - 5.40 p.m.

B. Niemiec, P. Rosmus, A. Trojnar, *Central Mining Institute, Poland*

### **THE INDICES FOR ASSESSING EFFECTIVENESS OF SAFETY MANAGEMENT SYSTEMS IN POLISH COLLIERIES**

Most of the Polish collieries have implemented by the end of the year 2005 a system of managing health and safety-at-work complying with the standard PN-N-18001 on occupational safety and health management systems. The authors perform in this paper an analysis of to what degree the observed increase in safety level is a result of the measures taken in connection with the process of restructuring mining industry and rise of general technical culture and to what this degree results from the implementation of the safety management systems. The trends prevailing in accidents statistics were identified and characterised and then related to their causes which were grouped into: faults in safety system, faults in organising tasks, faults in observing regulations, and mistakes of the injured. As a result of the analyses an aggregate trend index has been worked out and proposed for use as a criterion in assessing effectiveness of the safety management systems applied in collieries.

5.40 - 5.50 p.m.

R. Schumachers, *Central Division of Occupational Health, Safety and Environment of RAG, Aktiengesellschaft, Germany*

### **MINE SAFETY - A FUNDAMENTAL SUCCESS PARAMETERS FOR COAL MINING IN GERMANY**

RAG Aktiengesellschaft is generally acclaimed for its state-of-the-art mining technology and high health and safety standards. Recent years have seen the development of successful new mining practices along with the introduction of an extremely effective safety at work system. The company's long-term safety strategy and up-to-date management system, which have been based on an innovative health and safety policy and a dynamic organisational and procedural structure, create the framework that is

required for a successful industrial safety record. This paper will present a number of examples showing how mine safety can best be developed and organised and how the workforce can be made aware of their responsibilities and in this way can achieve even higher health and safety standards.

5.50 - 6.00 p.m.

*A. Aghajani, A. Bazzazi, M. Osanlo, Y. Azouni, Department of Mining Engineering, Islamic Azad University, Iran*

#### **AN EMPIRICAL FORMULA FOR FLY ROCK PREDICTION IN ESFORDI PHOSPHATE MINE OF IRAN**

Blasting is a primary means of extracting minerals and ores at surface mining operations. It is a hazardous component of surface mining. Serious injuries and fatalities result from improper judgment or practice during rock blasting. Fly rock from surface blasting operations has caused serious injury and death to employees and habitants, and it is always known as one of the major concerns for the blasters. During this research, fly rock distances for 15 blasts at Esfordi phosphate mine with blast design parameters have been monitored, and the influence of burden, stemming length and powder factor were analyzed. Based on the results, an empirical formula was developed to predict the fly rock distance and minimize the fly rock hazards at the Esfordi Phosphate Mine.

6.00 – 6.10 p.m.

*A. Fisne, G. Ökten, Istanbul Technical University, Turkey*

#### **OCCUPATIONAL NOISE EXPOSURE ASSESSMENT FOR UNDERGROUND COAL MINE WORKERS IN TURKEY**

One of the most important problems concerning health and safety in mining is to prolonged exposure to high levels of noise. Development of modern mechanized operations in mining industry has been considerably decreasing the physical burden of work. But the most undesired and unavoidable by-product of these operations is the generation of high levels of noise. Occupational noise exposure of mine workers is a potentially serious health problem. High-level of noise not only hinders communication between workers, but, depending upon the level, quality, and exposure duration of the noise, it may also result in different type of physical, physiological and psychological effects on the workers, especially noise induced hearing loss (NIHL). There has been little published research activity related to noise levels in underground mines in Turkey. The specific objective of this study was to estimate occupational noise exposure levels of mine workers in Zonguldak Bituminous Coal Mines in Turkey. It is employed approximately 10000 mine workers. Noise measurements were carried out in underground workplaces with the RION NL – 21 integrating sound level meter. After determination of exposure duration for each of the noise level, the daily noise exposure level of workers were calculated based on the method described in the standard ISO 1999:1990. The results showed that the task and tool with the highest exposure levels are production, preparation, transportation, shaft signal, mechanization and press, drilling and pump workers.

6.10 - 6.20 p.m.

*J. Colinet, J.P. Rider, E.D. Thimons, Niosh, USA*

#### **CONTROLLING RESPIRABLE DUST IN UNDERGROUND COAL MINES IN THE UNITED STATES**

As mining operations in the United States (US) have become more productive, controlling the dust exposure of mine workers has become more challenging. In response, US mining operations are applying basic controls at elevated levels and are looking to emerging control technologies in an effort to better control airborne respirable dust levels.

6.20 - 6.30 p.m.

O. Ozbayzoglu, S. Karakas, *Middle East Technical University, National Boron Research Institute, Turkey*

#### **HUMAN FERTILITY AND BORON**

Boron is an important element which is naturally found as boron-oxygen compounds. Commercial boron mineral deposits are located in Turkey and the USA, and also in Argentina, Chile, Russia, China, and Peru. Turkey with the world's largest borate deposits, is the main producer of boron compounds. Major uses of borates are in glass industry. Detergents, fertilizers, wood preservation, flame retardants, abrasives, herbicides, pharmaceuticals, nuclear applications, metallurgical fluxing, photography, textile finishing, armour protection and advanced composites are the other usage areas of boron compounds. People can be exposed to boron by the oral intake of foods, water, by consumer products or by inhalation of boron compounds in the working place during mining, processing, transportation. Boron is an essential micronutrient for plants. Although the mechanism of boron in human is not understood clearly, it appears to interact with other nutrients and plays a regulatory role in calcium and magnesium metabolism, bone growth, and insulin metabolism. Boron deficiency in animals results in poor growth and bone abnormalities. Boron is excreted in the urine with a half life of <24 hours in humans and animals. A new European Union regulation concerning the Registration, Evaluation, Authorisation and Restriction of Chemicals (REACH) came into force on the 1st of June 2007 and replaces a number of European Directives and Regulations with a single system. Boric acid and borates have been recommended to be classified as toxic to reproduction under Category 2 in 2004. According to scientific results, borates present no risk to human health during normal handling and use. This paper will review some of the researches carried out in Turkey and in the world about the effects of boron on human fertility and will provide the results of animal tests which can not be relevant to human.

6.30 - 6.40 p.m.

Al. L. Chobanov, *ASSAREL – MEDET ISC, Bulgaria*

#### **THE COMPANY POLICY FOR PROVIDING OF HEALTH AND SAFETY LABOR CONDITIONS**

Our contemporary society is setting higher challenges towards the development of the technologies for the mining and processing of ores and towards providing of such labor conditions, in order to have no risk for the life and health of the employees, or this risk to be within the minimum levels. For Republic of Bulgaria the providing of health and safety labor conditions is a requirement of the Constitution, Law for health and safety labor conditions, dated 1996 and the special Regulation, transposing Directive 92/104 of the EEU for the minimum requirements for safety and health in the mining of minerals /mines/.

6.40 - 6.50 p.m.

J. Martyka, *Central Mining Institute, Poland*

#### **SAFETY CULTURE IN THE PROCESS OF IMPROVEMENT AND VERIFICATION OF SAFETY MANAGEMENT SYSTEMS**

The conception of safety culture was presented in the paper, including its origin, notion and indexes, also possibilities of its practical usage: diagnosis of the condition of basic elements of safety culture of the coal mines' crew, efficiency verification of systems of safety management and execution of programme of limitation the risk in employees' behaviours. Discussed method of safety culture research can also become reliable instrument of efficiency verification of management safety system while implementing results of processed program of risky behavior modification (mainly procedure of risky behavior diagnosis and its reasons) inform of errors and neglects in safe work organization in mine. Generally, hitherto existing experience in practical usage of safety culture concept indicate, that it is next step in perfecting of management safety system

6.50 - 7.00 p.m.

K. Lebecki, P. Rosmus, *Central Mining Institute, Poland*

### **QUANTITATIVE RISK ASSESSMENT OF NATURAL HAZARDS IN MINING BASED ON EN-61508 METHODOLOGY**

Risk assessment when done properly during the planning stage for a production process is the deciding factor influencing work safety. In underground mining practice the level of tolerable risk for a given process is determined solely by confirming that safety regulations requirements are met. However, it does not mean that safety level for a given process is the highest possible. To achieve this goal clear risk assessment criteria are needed. This paper describes the new approach to quantitative risk assessment based on the EN 61508 methodology and also the concept of functional safety. For methane and/or coal dust explosion hazards the scenarios of the event are given in the form of a bow-tie tree. Analytical methods of FTA and ETA are used to assess the risk level. The tolerable risk threshold is calculated according to ALARP methodology, using the analytical methods of hazard identification - HAZOP and FMEA. Quantitatively expressed risk levels are calculated by the bow-tie tree method which specifies the confidence level for the given protection layer.

### **Part 3.1: METHANE TREATMENT**

**Venue: Middle Hall B**

Chairman: Jayne SOMERS, Co- Chairman: Jacek SKIBA

Secretary: Bartosz JURA

3.00 –3.15 p.m. **Opening ceremony**

Chairman: Jayne Somers (EPA), USA

Introduction into CMM activities

3.15 – 3.30 p.m.

Joachim Brandt, Erwin Kunz, *DMT GmbH, Germany*

### **GAS DRAINAGE IN HIGH EFFICIENCY WORKINGS IN GERMAN COAL MINES**

In order to increase production in gassy areas of coal mines the ventilation technique as a factor of production has also increasing importance. This is achieved by fans of high capacity as well as by cross-sections in the underground workings, which are as big as possible, especially in the gateways. The air-volumes cannot be enlarged unlimited, yet, and rapidly reach their maximum due to the limitation of the allowed air velocities. Besides that, a methane concentration of 1 Vol.- % in the maximum must be maintained in general, which is allowed to be exceeded only with the agreement of the mining authority in defined parts of workings up to a limit of 1,5 Vol.-%. Due to a dense sequence of coal seams in the German hard coal deposits, the firedamp is released during the exploitation not only from the worked seam, but essentially from the seams in the roof and in the floor behind the passage of the longwall. A gas drainage on the base of an efficient technique is necessary, firstly in order to fulfil the safety regulations and secondly to achieve a maximal production in the working. An investigation, recently finished and executed concerning the improvement of the gas drainage indicated that, by means of rock mechanical calculations and interpretations, an increase in the efficiency of gas drainage bore-holes is still possible.

3.30 – 3.45 p.m.

Krzysztof Cybulski, Eugeniusz Krause, Krystian Wierzbiński, *Central Mining Institute, Poland*

### **MODELLING OF METHANE CONCENTRATION DISTRIBUTION IN THE LONGWALL ENVIRONMENT IN THE AIR ROADWAY AREA**

In the span of last 15 years, a significant increase occurred of methane emission to environments of mining longwalls. It is influenced predominantly by increasing methane content of seams with depth of

mining, as well as at concentration of coal faces. An increase of coal faces concentration was accomplished mainly by enlargement of longwalls lengths, which has a bearing on increase of methane in place desorptionable quantity delivered from methane emission of underworked and overworked seams. In the paper, an importance of subject matter was indicated connected with cross-sections of workings adjacent to longwalls, in U-shape arrangement of longwalls airing along coal solid. Three-dimensional modeling of methane content distribution within the cross-section of ventilating roadway (with built-up brattice) with longwall, in dependence of its geometrical parameters and quantities of methane flowing from longwall and goaf, as well as assumed airing conditions, enables methane hazard assessment on the stage of mining design.

3.45 – 4.00 p.m.

Marek Kwaśniewski, Stanisław Lasek, *Faculty of Mining and Geology, Silesian University of Technology; Katowice Coal Holding Company, Murcki Colliery, Poland*

#### **NUMERICAL ANALYSIS OF METHANE MIGRATION FROM FLOOR STRATA TO A LONGWALL FACE**

A two-dimensional numerical model of a large (1000 m × 200 m) section of mine strata in the vicinity of seam 349 in longwall panel 802 in part B of the Murcki Colliery in the Upper Silesian Coal Basin, Poland, was built using the Universal Distinct Element Code *UDEC*. Longwall extraction of seam 349 with roof caving was simulated in the model over a length of 450 m. Mining-induced changes in displacements, strains and stresses in the mine strata were investigated and analysed. In particular, fracturing of rock masses was monitored and the development of zones was followed where joints between rock blocks underwent slip and/or separation and the so-called magistral fractures were created. It was found that the fractured zone in thin floor layers built of weak rocks develops more rapidly than the caving zone over the worked-out area and extends to a depth of about 30 m below the seam. At the same time the floor strata undergo an intense heave in the gob area; already at the early stages of mining, the upward movement of the strata exceeded 1.5 m. A fully coupled mechanical-hydraulic analysis was performed in which joint conductivity was dependent on the mechanical deformation and, conversely, the mechanical behaviour of rock masses was affected by joint fluid pressure. It was shown that migration of methane from coal seams lying beneath the mined seam is possible under conditions where the floor strata deform to a great extent, undergo separation, fracture and break into blocks. Under the assumptions that (i) methane-bearing strata occur 15.6 m beneath seam 349 and include seam 350 and the strata lying beneath, and (ii) the methane reservoir pressure is equal to 2 MPa, the direction, pressure, quantity and velocity of the methane flow through fractures developing in the floor strata affected by the extraction of seam 349 were investigated. It was shown that methane enters the longwall working suddenly, and in large quantities, after the start-up period of the longwall face, that is after the seam was mined-out over a length of 60-70 m. Further mining stages were accompanied by a less intensive inflow of methane into the longwall face and the gob area. However, in cases where individual fractures joined each other to form magistral fractures that intersected the entire series of strata lying between seams 349 and 350 and connected the methane-bearing strata with the longwall face and the gob area in the seam being mined, sudden and large outflows of methane from the floor strata occurred.

4.00 – 4.15 p.m.

Andrzej Tor, Henryk Badura, Antoni Jakubow, *Jastrzebie Coal Mining Company, Poland*

#### **APPLICATION OF STATISTIC PREDICTIONS FOR EVALUATION OF METHANE INFLOW IN LONGWALL**

The paper presents a new method for statistic prediction of methane inflow to region of longwalls. The developed forecasts take advantage of information collected by automatic measurement systems for parameters of ventilation networks. The average inflow of methane to longwall regions has been described by a mathematic model that represents a linear function of such variables as daily output, air volumes, barometric pressure and methane concentrations during preceding days, just before the day in question. Parameters of the adopted statistic model are estimated on the basis of observation and measurement directly prior to the day of forecast. Number of parameters encompassed by the adopted

model varies. The paper discusses application scope of the newly developed computer software for prediction purposes along with examples of forecasts. Subsequently, accuracy of the forecasts of methane inflow is analyzed, and the calculated parameters are compared to measurement results from longwalls in collieries of the Jastrzębska Coal Company plc. Nowadays, forecasts are generated by ventilation divisions of coal mines and anticipated results are used for correction and tuning of methane-preventing measures.

4.15 – 4.30 p.m.

A. Alexeev, B.Gryadushchii, *Institute for Physics of Mining Processes, Ukraine*

#### **OCCURENCE FORMS OF METHANE IN FOSSIL COALS**

A new property of coal substance has been discovered, which allows to form metastable solid solutions with methane. Methane in fossil coals occurs in three forms: free methane; adsorbed methane, and dissolved methane. Methane dissolves in aliphatic (disordered) component of coal substance. Methane intercalation between carbon networks of graphite-like crystallites is the probable mechanism. Methane shares in coals from the Zasydko Mine were determined using liberation kinetics (free methane); methane or helium volume difference at saturation (adsorbed methane) or NMR (dissolved methane).

4.30- 5.00 p.m. Coffee break

5.00 – 5.15 p.m.

D.V. Rudakov & I.O. Sadovenko, *National Mining University, Ukraine*

#### **MODELING OF COALBED METHANE MIGRATION IN MINED OUT ROCKS**

Uncontrollable methane migration becomes the serious safety problem in coalmining areas especially near abandoned mines while flooding. The developed procedure aimed at prediction of this process is based on coupled modeling of non-steady ground water flow and gas transport in fissured rocks with large voids. Time variations of firedamp evolution, methane concentration in workings and surface buildings, and gas leakage through the overlying bedrock are estimated numerically. The model was tested with using the mining and hydrogeological data typical of the central part of the Donetsk coal basin in Ukraine.

5.15 – 5.30 p.m.

Paweł Baran, Stanisław Hołda, Jan Macuda, Adam Nodzeński, Ludwik Zawisza

*AGH University of Science and Technology, Poland*

#### **DESORPTION OF METHANE FROM SELECTED LIGNITE COALS IN THE ASPECT OF PROCESSES OF GAS LIBERATION FROM COAL”.**

The gas contained in a coal bed is one of the essential factors in the phenomena of the outburst problems, of methane recovery and emission of greenhouse gasses. In this paper the results of the investigations on the methane sorption and desorption on selected lignite coals and application of the thermodynamic method to the description of the process of gas liberation from a coal bed are presented. Gas capacity of the lignite coal beds depends from the pressure of gas, the composition of gas, petrographic composition and rank of coal, contents of water and temperatures of the bed. Investigations concerned appearing of methane sorbed in the lignite coal beds, in biggest, substantiated areas in the area of Poland. The sorption and desorption isotherms were measured by means of the volumetric method. The obtained experimental data were described using the thermal sorption equation of virial form. The presented study of sorption and desorption provides new data with regard to storage processes and liberation of methane from lignite coals. Possible threats resulting from the presence of methane in deposits were analyzed.

5.30 – 5.45 p.m.

MA Shangquan, Chen Xuexi, Wang Yibo, Zhang Chao, *Changsha Institute of Mining Research, China*

**EXPERIMENTAL STUDY ON HOLE SEALING TECHNIQUE FOR MENSURATING GAS CONTENT IN COAL SEAM**

It is difficult question to mensurate directly gas content in coal seam. Most method is to be considered inevitably leaking gas during drilling in coal seam. In drilling hole, the back of samping device is pressurized for keeping press, the forepart of samping device start to sampling in rising press expecting level,. When completed sampling, the forepart of samping device close down automatically. The experimental result shows samping device can gain perfect actual gas content in coal seam, the error is less than 10%.

5.45 – 6.00 p.m. Discussion and comments

**8.00 p.m. Banquet at Auditorium Maximum Jagiellonian University, Krupnicza str., Restaurant Hall (Level -1)**

**10<sup>th</sup> September 2008**

**Day 4 (Wednesday)**

**Middle Hall: Part- B**

**Auditorium Maximum of Jagiellonian University,**

**Krupnicza str.**

**Session 4: INFORMATION TECHNOLOGY IN MINING**

Venue: Middle Hall: Part- B Auditorium Maximum

SESSION SPONSORED BY:



Chairman: Magnus ERICSSON, Co-Chairman: Teodor WINKLER

Secretary: Jarosław TOKARCZYK

9.00 - 9.15 a.m.

V. I. Bondarenko, I. A. Kovalevska, G. A. Simanovich, O. I. Koval, *National Mining University, Ukraine*

**COMPUTER MODELING OF MINE WORKING CLOSE ON MOVEMENT OF COALCONTAINED ROCKY MASSIVE**

Leading particulars of a hinged-block movement zone of percarbonic layered rock thickness nearby the entry at mining of flat coal layers are established and proved by computer modelling, with use of finite element method.

9.15 - 9.30 a.m.

Y.B. Gryadushchiy, R. O. Dychkovskyy, A. Dyczko, V. V. Ruskych, *National Mining University, Ukraine*

**SOFTWARE SIMULATION IN THE THIN COAL SEAMS MINING**

This work is was carried out as a part of the conducted researches in the frame of the USA Program of Civil Researches and Development Fund (CRDF) the Ministry of Education and Sciences of Ukraine and National Mining University USB 1-021-DP07: "Resistance of Geotechnical Systems Processes: Phenomena, Risks". We have made the analysis of computer technologies application in the mining and proposed the technology of the mine technical situation forecasting based on simulation models establishment.

9.30 - 9.45 a.m.

P. Afzal, R. Alvan Darestani, D. Kaveh Ahangaran, *Hampa Behineh Consultant Engineers, Iran*

**3D MODELING AND RESERVE EVALUATION OF MINEABLE COAL SEAMS IN EAST PARVADEH COAL DEPOSIT, TABAS, CENTRAL IRAN**

According to increasing energy consumption and price around the world especially petroleum and steel industries development in many countries and in otherwise, coking coal has an important role in developing countries economic. This subject and increasing price of coal in the world cause to brisk up coal



exploration around the world. Greatest coal field of Iran is situated in Tabas (Central Iran). East\_Parvadeh is biggest part of Tabas coalfield. Its area is over 50 km<sup>2</sup>. There was divided to 2 blocks attended major faults. East\_Parvadeh coal deposit coal seams modelling and reserve evaluation by RockWorks that one of modern geosciences software is done. In this paper, basis on results from general exploration stage C1 and B2 economic and mineable coal seams were 3D modelled and their reserves were evaluated by RockWorksTM v. 2006. Finally, this study was shown there is near to 233 Mt coal in these seams.

9.45 - 10.00 a.m.

N. Dobrițoiu, F. Bușe, I. N. Tiuzbăian, *University of Petrosani Romania, Romania*

#### **NUMERICAL MODEL FOR GENERATING HIDDEN SURFACES APPLICABLE IN THE PROCESS OF FIELD KNOWLEDGE**

In the knowing process of useful mineral substances deposits one request the determination of the surfaces which are borders of a body whom form it cannot be known with accuracy. The knowing of a deposit is achieved by geologic researching methods, but assumes great costs. The literature of speciality offer methods for establishing the form of deposits, but the results have an unsatisfactory accuracy. For the growth of accuracy, the researching have been pointed towards to the working out of a numerical model of deposit for drawing the contour of a plane surface, algorithm presented in this paper. Using this model leads to find the solution of the following problems: – the growth of accuracy of the values of geometrical parameters, which characterize a reserve unit; – the realization of any type of section by a reserve unit or deposit; – the swift fast updating of the databases.

10.00 - 10.15 a.m.

M. Monjezi, M. Hesami, H. Dehghani, *Tarbiat Modares University, Iran*

#### **PILLAR STRESS PREDICTION IN BORD AND PILLAR METHOD USING ARTIFICIAL NEURAL NETWORKS**

Determination of state of stress is a vital task in underground mining. After estimating stresses, pillar dimensions, roof conditions, etc. can be determined. There are several methods to estimate induced-stresses due to underground excavations, i.e. empirical methods, artificial intelligence, etc. Nowadays, artificial intelligence based techniques such as artificial neural networks are frequently applied in problems in which interactions among effective parameters are not easily understood. In this paper, a multi-layer back propagation neural network is developed for estimating state of stress in various locations of the pillars in bord and pillar mining method. A four-layer MLP with an input layer, two hidden layers and one output layer with architecture 5–48–12–1 is found to be optimal. On the basis of obtained results it is found that artificial neural networks method can be effectively utilized to predict induced stresses in various locations of the pillars. Also by sensitivity analysis, it is revealed that distance from line of caving, location with respect to the centre of pillar and angle of goaf line are the most effective parameters on the quantity of induced stresses.

10.15 - 10.30 a.m.

G. Massacci, V. Dentoni, B. D. Radwanek-Bak, *University of Cagliari, Carpathian Branch, Italy, Polish Geological Institute, Poland*

#### **VISUAL IMPACT OF SURFACE MINING AND QUARRYING**

The visual impact perception of surface mines and quarries mainly depends on the extent of the visible landscape alteration and on the chromatic contrast between the bare rock exposed by the excavation and the surrounding natural area. The quantification of the two physical parameters is included in the visual impact indicator  $L_{vi}$  (level of visual impact), which is a function of the visual solid angle subtended by the alteration from a selected viewpoint and the perceived chromatic difference between the bare rock and the area just around the excavation limits. The impact indicator was defined in a previous research work and afterwards applied to various cases of surface excavation in Sardinia and Poland. This paper discusses the application of the visual impact indicator to a number of selected quarries located in south-central Poland, within the provinces of Małopolska and Świętokrzyskie. For each study case various digital pictures were taken from the viewpoints that were considered representative of the

actual impact, as to include a variety of situations in which the visible quarry faces differ in size, colour and orientation. In some cases the photographs were taken with four different digital cameras, at the same time of the day and from the same viewpoint, in order to investigate the evaluation uncertainties related to the image acquisition system: relative differences up to about 33% have been found in the evaluation of the chromatic contrast whereas the determination of the visible alteration area has proved to be more precise. The comparison with the results obtained in a previous research carried out in the Polish Outer Carpathians has highlighted the effects of the season and the weather conditions on the actual visual perception. The main perspective for the development of this research is the definition of a standard procedure which ensures the repeatability of the result when evaluating the impact.

10.30 - 10.45 a.m.

Krzysztof Komorowski, *IBM Poland*

**DOES IT MATTER IN MINING? MANAGING THE CHANGE TO ACHIEVE THE VALUE PROMISED BY THE SOLUTION**

10.45 - 11.00 a.m. Coffee break

11.00 -11.15 a.m.

E. Widzyk-Capehart, D. Hainsworth, J. Cunningham, *CSIRO National Research Flagship, Minerals Down Under, QLD Centre for Advanced Technologies (QCAT), Australia*

**THE FUTURE MINE: CSIRO TRANSFORMATIONAL ADVANCES IN ORE EXTRACTION AND SENSING TECHNOLOGIES**

There is an increasing need for novel, autonomous mining systems to transform the viability of mining operations by minimising dilution, increasing recovery, increasing mining rates and allowing material discrimination or sorting near mining faces. To sustain future surface mining operations, remotely controlled (or fully automated) machines equipped with novel cutting technologies are necessary. New, non-contact rock sensing instrumentation needs to be developed to make the machines "intelligently aware" of geological terrain and to enable real-time navigation according to altered and/or unmapped geological conditions. In underground mining, transformational, non-entry mining methods using novel mining equipment are being recognized by mining companies as the future for mineral extraction. The benefits of developing these new technologies are numerous including: removal of personnel from hazardous conditions, reduce mining costs and increase inventory of economically mineable ore being brought on-stream in shorter time. Australia's Commonwealth Scientific and Industrial Research Organisation (CSIRO) is undertaking a number of major initiatives to address many of the needs of the future mine. This paper showcases CSIRO's state-of-the-art and planned future developments in the areas of longwall automation (LASC), mineral extraction methods (ROES™), drilling and cutting (SmartRods and SmartCut®), sensing technologies (GPR and Sirovision®) and risk management systems (Nexsys™).

11.15 - 11.30 a.m.

T. Winkler, M. Schmid, *KOMAG Mining Mechanization Centre, Gliwice, Poland*

**INTERACTIVE 3D SUPPORTS UNDERGROUND REPAIR AND MAINTENANCE OF ROAD HEADING MACHINES AND SHEARER LOADERS**

Increasing the output of mining machines is difficult to reach. Due to the advanced technical development of the machines, increased use of automation is here the objective. The analysis of daily work schedules of large machines, like the road headers and shearer loaders in German and Polish hard coal mines, show, that start-up, maintenance and repair times are of high potential for further improvement in the sense of increasing the daily period of operation. One possibility of reducing of downtime caused by underground assembly and disassembly work was seen in supplying of the necessary know-how right at the workplace. Technical complex machines require frequently expert knowledge and sometimes also the direct support by the manufacturer. Interactive 3D for support of underground repairs in the mining industry is one of the aims of current European Union funded research work. During the project

IAMTECH several ideas and solutions were converted into demonstration projects. Some of them were successfully integrated into the mining industry. Together the European partners developed a new knowledge management system based on interactive 3D models generated in real time [1]. Both the Knowledge Based Maintenance System (KBMS) and the Interactive Electronic Manual (IETM) on the one hand clearly simplify data base access by using Virtual Reality machine models. On the other hand existing knowledge is stored in interactive 3D applications and given to the underground mechanics on suitable terminals right at the workplace.

11.30 - 11.45 a.m.

T. Winkler, J. Jaszczyk, D. Michalak, J. Tokarczyk, *KOMAG Mining Mechanization Centre, Gliwice, Poland*

#### **APPLICATION OF COMPUTER MODELING AND VISUALIZATION METHODS IN THE LIFE CYCLE OF MINING MACHINES AND EQUIPMENT**

The designing methodology is characterised with transition from selection of design features of individual machines to planning the complete life cycle of complex mechanical systems. Thus, apart from computer-based models of design features of individual machines, computer models of the working environment come into existence: headings, transport roads and anthropometric features of humans. These models are "brought to life" with simulation of human and machine activities. Virtual prototyping is possible for design solutions for both the designed machines and for prototyping of processes executed with the existing machinery (mining, assembly/dismantling and underground relocation, repairs and maintenance). Operational knowledge developed during the use of the machines is also represented in the form of computer-based simulations and is managed with knowledge engineering methods. Knowledge repositories are made available through the webbased platform in all phases of life cycle of mining machinery.

11.45 - 12.00 a.m.

Z. Koszowski, J. Horodecki, J. Syrkiewicz, *Centralny Ośrodek Informatyki Górnictwa S.A. Katowice, Poland*

#### **COMPUTER-AIDED PRODUCTION PLANNING PROCESS IN THE HARD COAL MINING**

The paper presents the current status of works pursued by COIG S.A. in respect of IT solutions supporting the production planning process at mines and coal companies.

12.00 - 12.15 p.m.

R. Michalski\*, A. Dyczko\*\* *Konin Brown Coal Mine at Kleczew S.A., Poland*

\*\* *Mineral and Energy Economy Research Institute of Polish Academy of Sciences, Poland*

#### **DECISION-MAKING SUPPORT SYSTEM IN THE AREA OF COSTS' PLANNING AND EXECUTION OF OPERATIONAL TARGETS - CASE STUDY EXEMPLIFIED BY A BROWN COAL MINE**

The paper discusses the basic assumptions, architecture and phases of creation of an informatic system implemented in a brown coal mine, aimed at supporting decision-making in the area of costs' planning and execution of operational targets. The system was constructed basing on SAP BW tools, acting as an integrated and standard-complying data store, being a part of SAP NW- BI solution. The informatic system presented in the paper concerns Konin Brown Coal Mine in Poland and is a trial towards utilization of complex information, deriving from all modules of the implemented SAP ERP system and concerning a strictly defined group of users; it is also a proper way of proceeding towards working out solutions in other areas of company's activity.

12.15 - 12.30 p.m.

K. Hołodnik, W. Kawalec, *Instytut Górnictwa Politechniki Wrocławskiej, Poland*

**THE USE OF AN INTEGRATED MINING SOFTWARE ENVIRONMENT  
DEMANDED COMPETENCY OF A MODERN MINING ENGINEER**

The integrated set of courses containing computer aided geological modelling with geostatistics, surveying, mine design and planning including open pit optimisation and short term scheduling and blending have been developed since 1992 in the Faculty of Geoengineering, Mining and Geology at the Wrocław University of Technology. Courses are focused on methods of processing digital geology and mining data. Acquired knowledge and skills that meet modern mining industry requirements have already been applied by students in diploma works in various aspects of mining and appreciated by employers.

12.30 - 12.45 p.m.

Gurdeep Singh, Arun Kumar Shukla, *Indian School of Mines University, India*

**ENVIS CENTRE ON 'ENVIRONMENTAL PROBLEMS OF MINING' (MIN-ENVIS)**

Ever since its establishment in 1991, the ENVIS Centre at Centre of Mining Environment, Indian School of Mines University, Dhanbad (India) has been discharging its responsibly in collecting and storing information related to environmental problems of mining and disseminating it amongst the various users. In the field of mining, a mine manager or a mine planner needs to have a working knowledge in various aspects of environmental protection related to physical, biological and socio-economic environment in the mining region. This calls for special measures requiring focused attention towards dissemination of related information. Centre is accessible online since 2001 with a distinctive website having variety of information related to mining environment. Centre results publications on regular basis to disseminate useful, relevant, reliable and timely information on the mining environment so that every individual is able to take informed decisions for the future. Centre has also developed a bibliographic database in which the research articles are kept as soft copy for quick search and dissemination. Centre also collected many reports, research articles, proceedings and newsletters from various sources. All these hard documents are kept in the ENVIS library for ready references.

12.45 - 1.00 p.m.

P. Wojtas, J. Wojciechowski, T. Wałach, D. Cała, *Centrum Elektryfikacji i Automatykacji Górnictwa, EMAG, Katowice, Poland*

**COMPUTER SCIENCE APPLIED TO CENTRAL MINE CONTROL STATION  
SYSTEMS IN THE POLISH HARD COAL MINES**

The requirements for modern control systems have considerably increased in recent years. The volume of data at the disposal of the mine has been continuously increasing, along with improving and developing new metering techniques. Therefore, the system used for management over these data must not only legibly inform about the condition of the mine; it also must provide proper detail level and selection of data for specific, specialised mine services, including dispatchers, supervision personnel and equipment operators. Such scattering of information imposes, on one hand, the necessity of making the data available to the increasing number of recipients throughout the mining plant, and, on the other hand, the necessity of building reliable and flexible software with the latest available technologies with secure protection of the data and of the systems against unauthorised external access. These two conditions constitute opposite poles of the issues related to making the data available and presenting them and those of their security. The following work analyses problems and solutions used in modern supervision control systems on the example of the SD2000 control system, in the context of the latest IT solutions and planned development work.

1.00 - 3.00 Lunch

**8.00 p.m. Banquet at Auditorium Maximum Jagiellonian University, Krupnicza Str., Restaurant Hall (Level -1)**

**10<sup>th</sup> September 2008****Day 4 (Wednesday)****Seminary Hall****Auditorium Maximum of Jagiellonian University,  
Krupnicza str****Seesion 5: SUSTAINABLE DEVELOPMENT IN MINING INDUSTRY**

Venue: Seminary Hall

Chairman: Viktor A. KHARCHENKO, Co-Chairman: Wiktoria Sobczyk  
Secretary: Anna Ostręga, Radosław Pomykała**Part 1****Chairman: Monika Hardygóra**

9.10 - 9.30 a.m.

*Hana Gillarová, Czech University of Life Sciences of Prague, Faculty of Environmental Sciences, Czech Republic***LANDSCAPE MEMORY AS A SOLUTION OF THE ECOLOGICAL STABILITY OF THE TERRITORY AFTER MINING**

Comparing environmental stability coefficient of historic cadastres of Sokolov region and environmental stability coefficients of the current cadastres affected by brown coal mining, we may conclude that the memory structures of the landscape unambiguously determine the level of the current environmental stability of the territory. These memory structures represent continuous landscape segments containing a varying scope of original ecosystems that have been preserved since historical period of the development of the landscape by now. A complete detailed assessment of continuous landscape structures indicates that the scope of the share of these original landscape structures documented on indication sketches of the stable cadastre and described in the written part of so called „operate“ fully influences the value of the historic and current coefficient of the ecological of the landscapes as subject-matter to the comparison.

9.30 - 9.50 a.m.

*Jorge Gavronski, Companhia Riograndense de Mineracao, Brazil***DRIFTS FOR ELECTRICAL POWER GENERATION IN BRAZIL**

This paper looking the peculiarities of the Brazilian Electrical System, like the country's continental extension and the strong dependence on renewable energy (hydroelectric), discusses growth options according to the country's demands. It is done making reference to the world trends in diversified sources of power generation, priority of using native resources and environmental sustainability.

9.50 - 10.10 a.m.

*Vlasta Licková, Karel Houdek, Miroslav Martiš, Czech University of Life Sciences of Prague, Faculty of Environmental Sciences, Czech Republic***EVALUATE OF SCENARIOS OF RENEWAL LAKE MEDARD**

In cultural landscape there is a human sensation the surrounding of daily subsistence one of the most important issue. The aim of the project is to analyze and evaluate the different scenarios of resumption very specific landscape in Sokolov basin. The territory has a character open and soft landscape till the start of mining in the 1830-1840. The main raw material – brown coal had been minend till the year 2000. The whole area went through very intensive changes and now there are efforts to re-establish the functions and stabile landscape. After mining survive there huge pit which special liking for rise new

important element of this landscape – Lake Medard. This new trend-making element bears a lots of variable ways of usage: recreational role (children play arena, sands), commercially recreational role (golf course, roller-skates line, port), hotel services and conferential centre, college campus and many others. One of the different way is to leave in the lake and leave it to natural development. Till this time nobody ask the people which lives in the surrounding of incoming Lake Medard: “What do you wish?” or “What is your opinion to Lake Medard and its utilization?” Our aim is consider determinant functional element of this area – natural, cultural and social with regard to human well-being and evaluate partly scenarios of renewal this very specific landscape.

10.10 - 10.30 a.m.

Nadil Berbic, Amir Brigic, Admir Softic, *University of Tuzla, Bosnia and Herzegovina*

### **ANALYZE AND POSSIBILITY OF SOIL EMBANKMENT AND FOREST BELT APPLICATION AS A NOISE BARRIER AT OPEN PIT MINE**

Production at open pits is a problem that violates quality of living in the vicinity of open pit areas. This article deals with protection of noise problems by noise barriers such as soil embankment and forest belt application. There were adequate measurements conducted at the field. Based on obtained results there are basic objectives for a realistic appraisal of usage this way to protect vicinity of lorries atraces at open pit mine from noise.

10.30 - 11.00 a.m. Coffee break

## **Part 2**

### **Chairman Nadil BERBIC**

11.00 - 11.20 a.m.

Nobuyuki Masuda, *Japan Oil, Gas and Metals National Corporation(JOGMEC), Japan*

### **APPLIED TECHNOLOGIES TO PREVENT ENVIRONMENTAL RISKS AFTER MINE CLOSURE IN JAPAN AND FUTURE PERSPECTIVES**

Mine pollutions have been a serious issue in Japan since the 1970s. Efforts have been poured into technical development to recover the previous nature continuously for over 30 years. There are many successful R&D examples undertaken so far, and many of the results were practically applied to the abandoned mine sites. Accordingly, the problems aroused have been gradually solved, and most of them have been extinguished by these efforts. However, the AMD treatments must be continued as long as the pollutant is generated. Costs for perpetually continuing water treatment operation, disposal spaces for continually generating sludge, decrepit facilities and tightening regulations on the environment are recent emerging problems. In this paper, mining and environmental issues in Japan, including the outline of the legal structure and commonly used technologies to prevent mine pollutions, are explained. Then, technology outlines, results, applications and the implemented period of R&D projects so far carried out, such as ‘Vegetation of tailing dam areas’, ‘Adit plugging technology’, and ‘Sealing technology of mineralized zone’, etc., are summarized briefly, and the latest projects, such as ‘Bacterial oxidation and two-step neutralization process’, ‘Mine drainage control technology by polymer use’ and ‘Water treatment process for newly regulated elements’ are described as well. In the last part of this paper, future perspectives on the technologies are discussed. A basic concept of technologies on mine pollution prevention is considered that the mine pollution prevention is to prevent toxic substances diffusions; therefore a basic idea to prevent mine pollutions should be to prevent generation of the pollution itself, or to complete a treatment or disposition of the toxic substances only inside themine. To realize this basic idea, new technologies are proposed both for the ‘Mine drainage treatment’, which is to process and control the wastewater or seepage water quality under certain toxic contents levels to avoid the environmental impact on the downstream areas, and the ‘Pollution sources’, which are the way to mitigate the burden to the environment by controlling the pollution sources. To responding on the ‘New regulatory orders’ and to introducing the ‘Passive treatment’ which has not been practically applied in Japan, were discussed as well.

11.20 - 11.40 a.m.

Monika Hardygóra, Gabriela Paszkowska, Helmut Wolff, *Wroclaw University of Technology, Poland*

### **INTRODUCTION OF THE CONCEPT OF AN INTERNATIONAL MINING PROGRAMME IN THE EDUCATIONAL ENVIRONMENT OF CENTRAL EUROPE**

As an answer to the diminishing number of candidates forming programmes in many European countries and the continuous industry demand for highly qualified university graduates the concept of joined curriculum mining programmes was developed. The basic idea consisted of the establishment of educational networks, within which the students move, choose educational modules, take the required examinations, prepare their thesis and obtain the graduate engineer degree at one of the universities integrated in the network. An approved precursor for this structure was the European Mining Course (EMC). Later two other programmes have been added – European Geotechnical and Environmental Course was the last to join this structure. Development of an international joined curriculum and launching the programme is a difficult and complex process. It requires consensus among the partners in developing the optimum curriculum regarding expertise of the partners, programme requirements as well as industry suggestions, available facilities, possible technical trips, travel distances and costs. However the major obstacles in successful launching and running international joined curriculum programmes are administrative barriers at university level as well as national legal regulations. Running the programme is a continuous improvement process. Keeping up to high quality standards requires monitoring the students', teachers' and coordinators' feedback. Is this high effort worthwhile? This article presents the development process of the European Geotechnical and Environmental Course by 5 universities in Germany, Slovakia, Hungary and Poland. The threats and opportunities of the educational environment in Central Europe are shown as a background. Problems and challenges encountered, lessons learned and successes achieved are discussed. Some practical aspects as course contents and teaching methods, administrative procedures, cooperation among partner universities and the mining industry are introduced.

11.40 - 12.00 a.m.

Anatoly Galperin, Irina Postnikova, Alexander Kryuchkov  
*Moscow State Mining University, Russia*

### **NATURE PRESERVING FORMATION TECHNOLOGIES AND FURTHER USE OF MAN-MADE MASSIVES AT KMA-REGION**

During the exploitation of iron-ore deposits at Kursk Magnetic Anomaly (KMA, Central Russia) considerable areas of fertile black earth zone should be withdrawn from the usage. Engineering-geological and hydrogeomechanical investigations of hydrofilled man-made massives (dumps and tailing dams) give information about their granular and mineral composition, as well as mechanical properties and consolidation grade of their sediments. Estimating bearing capacity of weak natural and hydrofilled foundations, it may be possible to place dumps of soft soils and rocks on them.

12.00 - 12.20 p.m.

Iwona Kuczyńska, Anna Bednarek, Danuta Marcinkiewicz, Tadeusz Koperski  
*AGH University of Science and Technology, Ecology of Industrial Areas, Coal Mine „Halemba – Wirek”, Bituminous Coal Mine “Bielszowice”, Polish Hungarian Mining Joint Stock Co. Haldex, Poland*

### **SOME ASPECTS OF CONVERTING EXPLOITATION WASTE INTO MARKETABLE PRODUCTS**

Exploitation and beneficiation are main sources generating waste in the mining industry. Hard coal mining waste, if treated according to a novel procedure, could be transformed into full-value natural aggregates. Utilising existing technologies, the procedures of coal processing should be upgraded in such a way that beside coal another product (aggregates) be obtained or barren rocks, considered waste, formed after reprocessing marketable mineral aggregates and building materials. An exemplary installation producing not only coal but also natural aggregates meeting normative parameters has been

presented. Also the achievements of the PWG S.A. Haldex in producing such aggregates have been discussed.

12.20 - 12.40 p.m.

Jan Macuda, Ludwik Zawisza, *AGH University of Science and Technology, Poland*

**GEOCHEMICAL ANALYSES OF GROUND AIR WITHIN THE HOLE  
EXPLOITATION OF HARD COAL MINE KWK "MORCINEK"**

Closing of hard coal mines leads to quantitative and qualitative changes of a number of environmental factors. Water and ground are one of the most endangered environments under the negative impacts of mines' closing operations. Among the most important hazards are methane and carbon dioxide emissions from the coal beds. Intensification of gas flow to the surface area is most frequently caused partial or entire stopping of mine's waters pumping. This results in reconstruction of the Carboniferous aquifer, and consequently, the so-called „piston effect”. In the closed mined this effect may be considerably intensified after stopping ventilation of the abandoned workings. The results of geochemical analyses within a closed Coal Mine KWK Morcinek are presented in the paper. The investigations were aimed at evaluation of the scale of occurrence of mine's gases in the surface zone and principles of its detailed geochemical monitoring.

12.40 - 1.00 p.m.

Urszula Lorenz, Zbigniew Grudziński, *Mineral and Energy Economy Research  
Institute of Polish Academy of Sciences, Poland*

**MERCURY EMISSION AND ITS CONTENT IN HARD AND BROWN COAL**

Nowadays, mercury content in the environment is estimated to be two to three times higher than in the period before the industrial revolution. Three branches of industry: chlorine production by mercury method, cement production and coal combustion are the main sources of mercury emission to the air. Mercury is a natural component of coal. Combustion of coal (both hard and brown) on a mass scale in power plants, industrial plants and for communal needs, despite relatively small mercury content, contributes to significant load of mercury to the environment and presently is one of most important anthropogenic source of mercury. Mercury absorbed by human organism comes from many processes; moreover, it accumulates in organisms, so that it is hard to define emission limits for particulate sources. Thus, so far, there are not limits for mercury concentration, but in the nearest future it is planned to implement a complex strategy for this element. Such regulations, if implemented, would mostly concern coal, both hard and brown, as its combustion establishes one of the most important sources of mercury emission. As it derives from GUS (Polish Statistic Office) data, the current estimated level of emission from all sources in Poland makes ca. 20Mg and it remains unchanged since 2002. In comparison to the relation chosen by our country, the reduction made ca. 50%. Out of the studies conducted in Poland, it derives that average content of mercury in hard coal varies between 100 and 150 ppb (micrograms per kilogram;  $\mu\text{g}/\text{kg}$ ), while in brown coal – from 300 to 350 ppb. It seems, that taking into consideration the form of mercury presence in Polish coal, there are possibilities for a significant decrease of mercury content on the stage of coal beneficiation.

1.00 - 3.00 p.m. Lunch

**Part 3 - Chairman: Jorge GAVRONSKY**

3.00 - 3.20 p.m.

Battista Grosso, Marco Cigagna, *Department of Geoengineering and Environmental Technologies, University of Cagliari, Italy*

**TAILING BASINS IMPERMEABILIZATION WITH ELECTROSMOTIC  
TECHNIQUE**

In the mining area of Sardinia, many years after the end of industrial activity, a lot of tailing basins result as abandoned and constitute dangerous sources of contamination for groundwater and soils. Aimed at



avoiding the diffusion of contaminants, electroosmotic technique can be used to realise low permeability barriers both at the basin bottom and along its perimeter. The paper describes the experimental activity carried out for evaluating the effectiveness of the electroosmotic technique and its applicability to a specific case of tailing dam remediation.

3.20 - 3.40 p.m.

Zbigniew Hałat, Jan Józef Hycnar, *Max – Eko Sp. z o.o. , Poland*

### **PROPERTIES AND UTILIZATION OF DRILLING WASTE**

Drilling waste consists of hydrated, fine-grained rock drillings with thixotropic properties, which depend on the rocks being bored and the contents of applied drilling fluids. Taking into account physical-chemical properties of minerals as well as ion impurities included in drilling waste one can easily create thixotropic systems which provide for good waste penetration into the porous structure of deposits, formation of semi-flexible sealing layers, erosion control of covered or filled deposits and fermentation processes, etc. The above properties brought about the effective utilization of drilling waste for preventing the self-heating and dusting of dumping grounds as well as dusting of waste and dusting materials, and for sealing and recultivation of mining-waste dumps and leveling the degraded areas. Closing down of worked-out or shut-down municipal landfills covers, among other things, their leveling and degassing, surface sealing, biological recultivation, eluate disposal from dumping ground body and monitoring the landfill after its close-down. The desired effects can be achieved e.g., by covering the landfill surface with appropriate layers, usually three of them, namely: a degassing layer, proper sealing layer and biological recultivation layer. By means of drilling waste selection, separation of mud fraction from drilling waste and through addition of clay substances or/and binding agents to drilling waste, there can be acquired some materials meeting the requirements for particular layers.

3.40 - 4.00 p.m.

Miranda Ptak, *Regional Mining Council, Wrocław, Poland*

### **THE USEFULNESS OF SELECTED SCIENTIFIC METHODS TOO SOLVES THE CONFLICTS OF FACE MINING AND REGIONS NATURE 2000**

The induction into the legal system of the new form of environmental protection, e.g. regions covered by Nature 2000, causes in many cases the lack of ability or need to restrict or control facemining. The following article presents a short analysis of the usefulness of selected scientific methods to solve the conflicts of face mining and regions Nature 2000. The authors are highlighting the need to create an objective method, which will assist the decision making processes concerning the possibility of trade practice in the region of Nature 2000. And so, in round of investigation for a suitable method for optimal taking up and objective solutions in conflictual situations with nature 2000, methods have been placed with utilization of neuron network, analytical hierarchic process, estimates of environmental risks. To the analysis were accepted methods which (who) have been checked in systems of aiding decisions at the nature of multiple criteria, about similar thematic range. Methods, scope of implementation is multi criteria, presence of measurable and immeasurable data as well as surfaces of conditionality which seems to make the decision of the prime problem. All the above mentioned methods require modification in order to apply them to a method, which will make it possible in an objectified manner to open a face mining trade in conditions of areas of Nature 2000. Unmistakably the fact that belongs to the advantage of introduced method, is that: — They supply simple, understandable and elastic model for multi criteria problems. — They order and criteria systematize important factors. — They integrate inferential reflection and system approach for problem solving compound. — They introduce scale of estimate for immeasurable elements. — They analyze problem in interdisciplinary surfaces. — They assure capability of recurring analysis. Elaboration of such method will help aid the decision making process, it will objectify it and turn for optimal choice variant taking into consideration all important factor, those environmental, geologically – engineering, economic, as well as social.

4.00 – 4.30 p.m. Discussion and comments

4.30 -5.00 p.m. Coffee break

5.00 – 5.20 p.m.

Józef Sułkowski, Jan Drenda, Zenon Różanski, Pawel Wrona, *The Silesian University of Technology, Poland*

**NOTICED IN MINING AREAS, ENVIRONMENTAL HAZARD CONNECTED WITH OUTFLOW OF GASES FROM ABANDONED MINES AND WITH SPONTANEOUS IGNITION OF COAL WASTE DUMPS**

Abandoning the mining does not solve some aspects connected with negative impact of the mines on environment. Problem of CO<sub>2</sub> emission from closed-down mine to the surface of Zabrze and Ruda Śląska cities has been discussed in the article. Inaccurately abandoned shafts can be a source of CO<sub>2</sub> emission to the atmosphere, therefore they must be considered in programs of air protection. However, they mostly create a hazard for public safety what should be avoided by proper prevention. Coal waste dumps are the next negative consequence of coal mining. Fire hazard is caused by: contents of combustible components, used methods of storage and insufficient fire prevention. Negative influence of this process on the atmosphere has been discussed. Fire prevention and fighting methods applied in Poland have been presented.

5.20 – 5.40 p.m.

Andrzej Ślęczka, Zdzisław Piszczyński, *Silesian University of Technology, Poland*

**EFFECT OF SELECTED ADDITIVES ON THE STABILITY AND RHEOLOGY OF COAL-WATER SLURRY FUELS (CWSF)**

The influence of selected additives on the rheological properties and sedimentation stability of highly loaded coal-water slurries (CWS) were tested from the point of view of usage them as a slurry fuels. As additives four nonionic surfactants and two anionic surfactant were chosen. They were polymers made on the basis of polyoksyethylene and polycarboxylic resin. The results showed that it is possible to get slurry having satisfactory rheological properties and stability for usage them as a fuel.

5.40 – 6.00 p.m.

Jan Lubaś, Marcin Warchoł, Piotr Krępulec, Tadeusz Wolnowski, *Oil and Gas Institute, Krakow, Poland*

**GREENHOUSE GAS SEQUESTRATION IN AQUIFERS SATURATED BY NATURAL GASES**

It has been estimated that without real efforts to reduce greenhouse gas emission the global temperatures will rise by several degrees altering the world's climate. The coal contributes 95% to electricity generation in Poland. Therefore, low carbon emitting technology with the capture and underground storage of CO<sub>2</sub> is required in our country. Deep saline aquifers have the largest long-term storage potential of CO<sub>2</sub>, but there are many problems with their exploration and qualification due to the lack of tightness confirmation. It is very important to reduce the cost of their exploration performed mainly by expensive drilling. In existing mega aquifers saturated by natural gases their tightness is confirmed by the presence of many local gas accumulations in top structures. In this paper we present Poznań Trough megaaquifer naturally saturated by native natural gases. This megastructure represents a great potential for long-term underground CO<sub>2</sub> storage on 5000 km<sup>2</sup> area. Oil & Gas Institute and Polish Oil & Gas Company has gained a lot of experience in acid gas capture and storage. The acid gas containing 60% of CO<sub>2</sub> and 15% of H<sub>2</sub>S reinjected into an aquifer directly underlying the Borzecin gas reservoir has been in operation since 1996. Apart from technological parameters we also analyzed the process of displacement of native natural gas which originally saturates the underlying water by acid gases injected into reservoir. Such a displacement process allows to replenish the gas cap by volume equivalent to methane gas dissolved in underlying water. The PVT study results indicate that volume of methane gas displaced from reservoir waters is in direct proportion to volume of CO<sub>2</sub> injected into reservoir and that acid gas concentration in hydrocarbon gases being displaced from reservoir is gradually increasing.

**8.00 p.m. Banquet at Auditorium Maximum Jagiellonian University, Krupnicza str., Restaurant Hall (Level -1)**

**OUTGOING SESSION**10<sup>th</sup> September 2008

Day 4 (Wednesday)

EMAG

Ul. Leopolda 31, KATOWICE

Congress Sponsor



Research and Development Centre for Electrical  
Engineering and Automation in Mining EMAG,  
Katowice, Poland



Central Mining Institute  
Katowice, Poland

**Session 6: COAL MINING – CHANCES AND CHALLENGES**

Venue: EMAG, 31 Leopolda Str., Katowice

Chariman: Jan Palarski, Co-Chairman: Renata Patyńska

7:45 a.m.

Meeting of the participants at the Main Hall of Auditorium Maximum of the Jagiellonian University, Krupnicza 35 Str.

9.45 a.m. Arrival in Katowice

10.00 - 10.30 a.m.

Opening lecture: Jan Palarski, *Silesian University of Technology, Poland***GLOBAL PROBLEMS OF THE HARD COAL MINING**

The role of coal in world economy, main producers and significant achievements of a coal mining sector are presented in the paper. Results of world's leading producers of coal were compared with the achievements of the Polish mining industry as the biggest producer of coal in EU. Geology of deposits as well as mining conditions are reviewed and discussed. Further, original Polish technologies and current research projects focused on clean coal technologies are presented in the paper.

10.30 - 10.45 a.m.

M. Myszkowski, U. Paschedag, *Bucyrus DBT, Europe GmbH, Germany***LONGWALL MINING IN SEAMS OF MEDIUM THICKNESS - COMPARISON BETWEEN SHEARER AND PLOW**

Longwall mining allows the most effective underground coal extraction method today. A large part of global coal reserves is located in seams between 1.5 m and 2.3 m thick; these are often high-quality reserves. The question is whether the use of a shearer or of a plow longwall system is economically better. Only a comprehensive comparison of both longwall mining methods, looking at the latest system technology available results in an in-depth analysis of all relevant geological, technical, procedural and economical aspects and allows operators to find the best solution to mine their individual deposit.

10.45 - 11.00 a.m.

Dou Linming, Li Zhihua, Lu Caiping, Mu Zonglong, *State Key Laboratory of Coal Resource and Mine Safety, China University, China*

#### **Study of the Influence of Exploitation on Fault Rock Burst in Coal Mine**

The influence of the mining operation on fault stress and shear displacement are researched through mechanical analysis of roof rock-mass balance structure and numerical simulation about fault slide destabilization. The results indicate that the shear displacement increase sharply caused by the normal stress decreases and shear stress increases of fault plane when working face advances from the foot-wall to the fault. Conversely, the normal stress increases and shear stress decreases, the magnitude of shear displacement is small when working face advances from the hanging wall to the fault.

11.00 - 11.15 a.m.

V.N. Oparin, A.P. Tapsiev, V.A. Uskov, *Institute of Mining, Siberian Branch, Russian Academy of Sciences, Russia*

#### **Challenges and new engineering solutions on modernization of underground productive mines**

The rising world-market prices of metals (copper, nickel, gold, platinum, etc.) challenge for involving lean ore deposits, then of no demand, into development. Accordingly modernization of the productive mines with their output to be raised by a factor of 2 or 3 is an impelling need of the present day. The use of a new high-performance mining equipment is complicated due to small sizes of the existing haulage roadways, insufficient capacity of the hoists and ventilation, mismatch of the old mining methods and the up-to-date machinery applied. This paper describes new, umbrella approaches to these problems in terms of Siberian mines. From the advanced engineering solutions developed by the researchers of the Institute of Mining, SB RAS, the overhand ore breaking technology, slice mining with ore shrinkage and longwalling by top-slicing are emphasized.

11.15 - 11.30 a.m.

S.B. Tulub, G.G. Pivnyak, *Ministry of Coal Industry of Ukraine, Ukraine*

#### **Problems Of Development Of Coal Industry Of Ukraine**

Advanced problems of coal industry of Ukraine in context of tendency of power industry development in 21-st century, and structural market changes in economy of Ukraine are considered. There are described current situation in coal industry as well as privatization processes of the branch enterprises, strategic tasks of coal industry of Ukraine for the near future. There are shown conditions and methods under which coal industry of Ukraine will become competitive and will be able to meet the demands of environmental protection.

11.30 - 11.45 a.m.

Z. Będkowski, D. Kot, J. Krodkiwski, W. Mironowicz, T. Sikora, *Research and Development Centre for Electrical Engineering and Automation in Mining EMAG, Poland*

#### **Control And Monitoring Of Chosen Technological Processes In Coal Production**

The evolution of control and monitoring of technological processes in coal production has been discussed in the paper. Examples of the latest solutions being used in technologies of coal getting and preparation have been presented as well. Functionality and compatibility of these solutions regarding in particular their use in various applications have been characterized. There has been emphasized the importance of control and monitoring for improvement in work safety and efficiency of production as well as the directions of the further development have been indicated.

11.45 - 12.00 a.m.

E. Cozma\*, I. Onica\*, B. Cozma\*, G. Chiril\*\*, \*University of Petroșani, Romania,  
\*\*National Hard Coal Company Petroșani, Romania

### **Coal Mining In The Jiu Valley Basin - Achievements And Expectations**

The Jiu Valley hard coal basin represents the most important hard coal deposit of Romania, which ensures a coal annual output of about 3.5 million tonnes. From the total of 22 coal seams, the thick coal seams no.3 and no.5 represent approximately 60% from the total coal reserves and more than 95% from the coal output capacity of the entire basin. The hard coal mining is organized in the perimeters of 7 underground mines, within the framework of the National Hard Coal Company Petroșani. In this paper there are presented a series of general data regarding the geology, the geomechanical and geo-mining characteristics of hard coal deposit, etc., some achievements and expectations and the main long and short-term fundamental objectives of the Coal Company.

12.00 - 12.15 p.m.

B.B. Senokane, *The Department of Systematic Theology and Theological Ethics, South Africa*

### **The Eyes Of The Beholder. An Ethical-Social Perspective on New Challenges and Visions for Mining**

There has never been justice and there will never be justice as long as mining sector and its experience are told from only one point of view, that is, the owners' and shareholders' point of view. A one sided point of view jeopardise justice. The advertisements and publications of the congress concentrated on a one sided point of departure, which was, digging and production, even though the theme of the congress was on "New Challenges and Visions for Mining". This poses a big question of why was this. Was this intentionally, was this mistake, was this because of ignorance, or was this not really an issue? It might have been intentionally because workers are just like mere objects and means to diggers' ends. It might have been a mistake because diggers usually disregard, disrespect, and undermine workers. And this makes workers invisible before the eyes of diggers. It might have been ignorance because diggers even forget that workers exist or are a family of the mining sector. And this is troubling because the expectation is that one might never forget his/her family member even if he or she is no longer important to your family. You might need them at certain point; at least my African culture influences my position. It might not be an issue because of who cares about workers, money is the norm of diggers and they care only about making money. Based on my claims and accusations, there is therefore a need to present and acknowledge that 'mine-workers' are human beings with identities, emotions, values, aspirations, culture, tradition, families, and are part of a bigger society.

12.15 - 12.30 p.m. Discussion (key-problems of hard coal mining)

12.30 - 1.30 Lunch

1.30 - 2.00 p.m. Departure to Mines

2.00 - 5.30 p.m. Technical Visit in (optional):

1. Underground coal mine: KWK "Wieczorek" Coal Mine, KWK "Staszic" Coal Mine
2. Experimental Mine "Barbara", Central Mining Institute
3. EMAG

6.00 - 8.00 p.m.

Mining dinner *Cottage under the Linden*, „Dworek Pod Lipami", Katowice Giszowiec

8.00 p.m. - return to Krakow

**Outgoing session**

**10<sup>th</sup> September 2008**

**Day 4 (Wednesday)**

J. Wyżykowski Hall,

**KGHM Polska Miedź S.A.**

**ul. M. Skłodowskiej-Curie 48, Lubin**



**Organiser of the session**

**Session 7: ORE MINING – TRENDS AND CHALLENGES**

Venue: outgoing session - J. Wyżykowski Hall, KGHM Polska Miedź S.A.

Chairman: Herbert WIRTH, Co- Chairman: Janusz REŚ

Secretary: Wojciech KĘDZIA, Andrzej KATULSKI

**9<sup>th</sup> September 2008**

- 9:00 meeting of the participants at the Main Hall of Auditorium Maximum of the Jagiellonian University, 35 Krupnicza Str.
- 9.15 departure for World Mining Expo Exhibition (Sosnowiec)
- 11.00 a.m. – 2.30 p.m. Visit to World Mining Expo Exhibition
- 2.30 p.m. departure of session World Mining Expo Exhibition
- 6:00 p.m. arrival in Legnica, accommodation at Qubus hotel

**10<sup>th</sup> September 2008**

8:00– 12:00 a.m. - trip to the ore mines Lubin, Polkowice-Sieroszowice, Rudna (15 people groups) and the trip underground

12:00 – 12:30 p.m.– Reception

12:30 - 4:00 p.m. - Lecture session

12:30 p.m.

**OPENING OF THE SESSION AND WELCOME BY THE - PRESIDENT OF THE KGHM POLSKA MIEDŹ S.A.**

12:45÷1:00 p.m.

Herbert Wirth, *KGHM Polska Miedź S.A.*

**KGHM POLSKA MIEDŹ S.A. LEASING PRODUCER OF COPPER AND SILVER**

1:00÷1:15 p.m. :

Li Aibing\*, Zhou Amin\*, Yin Yanbo\*, Liu Zhengyu\*, Zhou Ping\*, Liu Lanming\*\*, Chen Jiejing\*\*, Yuan Jieping\*\*, Yang Jingsheng\*\* \*Changsha Institute of Mining Research, Changsha, China, \*\*Hunan Shizhuyuan Nonferrous Metals Corporation, Chenzhou, China

#### **THE CAVING MINING SAFE CONTROL TECHNOLOGY ON THE MULTI-MINED-OUT-AREAS CONDITIONS OF THE SHIZHUYUAN POLYMETALLIC MINE**

The Shizhuyuan polymetallic mine was mining by room-and-pillar open stope method for more 10 years. After 36 designed rooms are mined out, left 2,600,000m<sup>3</sup> mined-out areas with 8000 m<sup>2</sup> of the maximum continued exposed face of roof without filling for some reasons. For the mine sustainable development and the safe mining, one mainly issues is how to management of mined-out-areas and the pillar mining. So some study was carried out: 1) After the engineering geological evaluation, the mechanics parameters of rock mass was derived by generalized Hoek-Brown failure criterion. 2) Many mining schemes for directed to the determination of mining method were modeling by the 3D elastic-plastic finite element method. Based on the modeling results, the caving method was chosen. 3) Cavability (i.e. caving areas) of the Shizhuyuan polymetallic mine was worked out by Laubscher and extended Mathews methods. The height of buffer layer for different cave area of mined-out-areas was established. 4) For the purpose of safety mining, the ground pressure monitoring system such as Acoustic Emission (AE), displacement and pressure method that suit for the hard rock were designed and installed. The technological routes of the ground monitoring and an early warning case are listed.

1:15÷1:30 p.m.

A.A. Eremenko\*, V.A. Eremenko\*, T.V. Lobanova\*\*

\*Institute of Mining, Siberian Branch, Russian Academy of Sciences, Novosibirsk, Russia, \*\* OAO Eastern Scientific-Research Ore Mining Institute, Novokuznetsk, Russia

#### **DECREMENT OF RISK AND ABATEMENT OF NATURAL AND TECHNOGENIC HAZARDS WHEN MINING IRON-ORE DEPOSITS IN GORNAYA SHORIA AND KHAKASIA**

The authors study the dynamic phenomena arising with mining at iron-ore deposits in Gornaya Shoria and Khakasia, Siberia. Based upon geological and geophysical monitoring, it has been found out how the natural and technogenic events affect the state of a rock mass. In the course of experimental and theoretical investigations, the spatial and energy distribution was determined for rock shocks with different seismic energy, and the main tectonic structures activated by commercial blasting were identified. The study result was the defined regularities of formation of the geodynamic phenomenon concentration zones within a minefield and in a host rock mass. The recommendations are given for precautions against rock shocks in terms of the mines in Gornaya Shoria and Khakasia.

1.30÷1.45 p.m. :

D.R. Kaplunov, M.V. Rylnikova, D.N. Radchenko, *Research Institute of Comprehensive Exploitation of Mineral Resources, RAS, Russia*

#### **INTERGRATED TECHNOLOGIES OF ORE DRESSING WASTE UTILIZATION FOR THE EFFICIENT BACKFILLING OF MINED - OUT AREAS**

The problem of efficient technologies for the formation of technogenic solid monoliths with the use of the available materials is pressing for most mines operating at valuable ore deposits. High cost of imported cement, particularly in conditions of the current cement price escalation, great expenditures required for the preparation of filling mixtures including such processes as rock, slag and other component crushing contribute greatly to the growth of costs of ore mining with backfilling. At the same time, in the areas of ore mine operation great tonnages of already crushed ore dressing wastes have been accumulated. This material is readily available as a component for backfilling mixtures.

1:45÷12:15 p.m.: Coffee Break

2:15÷2:30: p.m.

Andrzej Rewak\*, Dariusz Kubiak\*, Janusz Reś\*\*, Piotr Gospodarczyk\*\*

\*DFM ZANAM-LEGMET Ltd, based in Polkowice, Poland

\*\*AGH University of Science and Technology in Kraków, Poland

### **„SELF-PROPELLED HAULAGE TRUCK – WKPL 30HS WITH A MODIFIED DRIVE SYSTEM”**

Polish Copper Corporation KGHM Polska Miedź currently operates front-wheel drive trucks with the loading capacity 20–28, intended for operation in inclined workings with the longitudinal dip of up to 8° and transverse dip of up to 5°. However, mining operations in the nearest future shall be conducted in more adverse conditions (higher rock temperature, larger inclination) and currently employed machines do meet the user's requirements. The need arose to design a new haulage truck intended for service in extremely difficult conditions in deep underground copper mines. The study outlines the key design objectives and the conceptual design of a four-wheel drive to ensure better traction capabilities; hence the new-design trucks can be operated in more inclined workings (longitudinal inclination up to 15° and transverse up to 8°). The structure of a hydrostatic drive system is shown and state-of-the-art solutions improve the truck's functional features: better loading capacity approaching 26 Mg, small height relative to the load capacity (2100 mm) and new-generation construction. The targeted research grant, supported by the Ministry of Education and Research in Poland, led to the development of a new design of a haulage truck WKPL 30HS and operational tests were performed. The paper summarizes the test data collected to date, with the major focus on further development and improvements.

2:30÷2:45: p.m.

Mohammad Karamoozian, Mohammad Reza Moghaddam, *University of Applied Science and Technology- Kerman- Iran*

### **„FLOTATION CIRCUIT CONTROL USING LATIN HYPERCUBE SIMULATION”**

Most mineral processing system models include variables that have either systematic errors or randomness associated with them. It is essential to incorporate these uncertainties when analyzing these models. However, evaluating models that contain random variables by exclusively using point estimate values does not incorporate the uncertainty of the independent variables and does not provide complete results. Therefore, incorporating the uncertainty when evaluating the mineral processing model can lead to correct results. Latin Hypercube simulation can obtain more accurate results when it is used to analyze the variance of complex or non-linear system equations. In this paper, a flotation circuit is simulated by the Latin Hypercube method. Much information is obtained by applying this method that is very important to process design and control.

2:45÷3:00 p.m.

Georgi Mihaylov, *University of Mining and Geology, Sofia, Bulgaria*

### **„ALTERNATIVE TECHNOLOGICAL SOLUTIONS IN UNDERGROUND ORE MINING”**

The alternative technological solutions in use in underground ore mining are summarized. Finding the zone of optimal solution is a basic aim of modern methodology for analysis and assessment of mining technologies. The problem is complex in nature and necessitates successive analysis of their separate elements. 1. Alternative technological solutions in opening up the orefield. The factors influencing the choice of opening-up method by using a vertical shaft or an inclined shaft and the associated optimal solution are pointed out. Indices are proposed for assessing the technological solutions, some of which being formulated in an original way. 2. Alternative technological solutions in developing the orefield. A model is created for the development operations. This model, besides the production costs, takes into account the ore loss and dilution in the stope development process. 3. Alternative technological solutions in selecting the mining technology. As a result of the complex investigations performed, it is proposed that the classification of the mining methods should be based on the number of stages, namely, single-stage and multi-stage mining technologies. 4. Criteria for assessment and limiting conditions. In



## SESSION 7

21st World Mining Congress, 7-11.09.2008, Kraków, Poland

---

the particular case, a 3D scale of limiting conditions is used. The analytical expressions derived allow the construction of a body in space of definite shape and size in which an optimal technological solution can be found.

3:00÷3:15 p.m.

Susumu Okabe, Jiro Yamatomi, Shinsuke Murakami, *The University of Tokyo, Tokyo, Japan*

### **„PRODUCTION SCHEDULING FOR OPEN PIT OPERATIONS CONSIDERING METAL PRICE CHANGES”**

A computer code for production scheduling considering metal price changes for open pit operations is developed, using 4D network relaxation method, which is one of Lagrangian parameterization methods. This method has a disadvantage in calculation time, but it has flexibility and practical usefulness. Namely, it can consider the discount rate, metal price changes and the dynamic cutoff grade. Therefore a case study on a gold deposit is carried out to evaluate this method with various metal price paths. The potential effectiveness concerning metal price changes of this method is shown in the case study, while more case studies would be needed for more precise validation.

3:15÷3:30 p.m.

Jan Butra, *Wroclaw Technical University, Poland*

### **MINING OF COPPER ORES IN POLAND**

3:30÷4:00 p.m. Discussion

4:00÷4:30 p.m. Guests' presentations

4:30 - 7:00 p.m. Mining picnic

7.00 p.m. – Return to Krakow

**OUTGOING SESSION**

**10<sup>th</sup> September 2008**  
**Day 4 (Wednesday)**  
**BOT KWB Bełchatów S.A**  
ul. Św. Barbary 3, Rogowiec



PGE KWB Bełchatów S.A.

Organiser of the session

**Session 8: OPEN PIT MINING - TRENDS AND CHALLENGES**

Venue: BOT KWB Bełchatów S.A., Rogowiec

Chairman: Admir SOFTIC, Co-Chairman: Leszek TLAŁKA  
Secretary: Paweł KRZYWORĄCZKA, Anna SOŁTYS, Józef LIMANÓWKA

**9<sup>th</sup> September 2008**

9:00 meeting of the participants at the Main Hall of Auditorium Maximum of the Jagiellonian University, 35 Krupnicza Str.  
9.15 departure for World Mining Expo 2008 (Sosnowiec)  
11.00 a.m. – 2.00 p.m. Visit to World Mining Expo 2008  
2.00 p.m. departure of session to Bełchatów  
7:00 arrival in Bełchatów, accommodation at the hotel  
8.00 Dinner

**10<sup>th</sup> September 2008**

7.00 - 7.45 a.m.  
Breakfast

8.00 - 8.15 a.m.  
Opening of the Session

**8.15 - 8.40 Opening lecture - PGE KWB Bełchatów S.A.**

8.40 - 8.55 a.m.

Z. Kasztelewicz, J. Klich, W. Koziół, M. Zajączkowski, K. Koziół, *AGH University of Science of Technology, Poland*

**LIGNITE INDUSTRY IN POLAND - PROSPECTS OF DEVELOPMENT IN XXI CENTURY**

Poland has an enormous proved lignite reserves and it is one of the biggest producer of electricity from this energetic source in the EU. But Poland has still low factor of electricity consumption per one citizen

comparing to other countries. That factor is twice lower than in Czech Republic or Russia, not saying about other the EU countries. It is confirmed the necessity of increase of the electricity request in the future. All scenarios of polish economy development, formulated by particular polish governments, predicts lignite extraction at the level of about 65 million Mg per year in 2030. But there is a lack of instructions, that indicate from which of the lignite deposits and in which regions that extraction should be performed. Polish energetic policy should answer the strategic question, on what fuel polish energetic should be working in the future? In 2030 electricity gross production can come to: min. 300 TWh and max. 350 TWh. Settling down the perspective lignite deposits: Legnica, Gubin-Mosty, Zloczew, Rogozno, Piaski, Kozmin central field, Oscislowo, Tomislawie, Deby Szlacheckie-Izbica Kujawska or Makoszyn- Grochowiska in 30–40 years would allow to increase the lignite exploitation level up to about 100– 120 million Mg a year and make it stable on this level for at least 50–100 years. That level of lignite exploitation would guarantee a doubling of current lignite electricity production up to level of 15– 20 thousands MW. The paper presents the state and the production possibilities of lignite mines in currently operating mining regions in Poland. The characteristic of perspective reserves of lignite as well the possibilities of their opening for the purpose of energy sector are described. The analyst concerns the perspective reserves like Legnica, Gubin-Mosty, Zloczew and other deposits in Konin-Turek basin and shows their possible development in the aspect of power sector development in the next 50–100 years.

9.00 - 9.15 a.m.

V. Ravikumar, R.Deivam, R.Paramasivam, *Neyveli Lignite Corporation Ltd., India*

#### **NEYVELI LIGNITE MINING- TECHNICAL DEVELOPMENT A CASE STUDY**

Neyveli Lignite Mines play a major role in generating the energy needs of several states of South India. Lignite mining at Neyveli commenced about half a century ago by Neyveli Lignite Corporation Ltd (NLC), a Government of India Enterprise. Continuous mining technology using Bucket Wheel Excavators (BWE), Belt conveyors and Spreaders was adopted. The transfer and adoption of Bucket Wheel Excavator technology at Neyveli was a landmark event, and it has helped the company to reap profits during its life. The successful deployment of BWEs was made possible by adopting suitable modifications in the design of the buckets, teeth and structural parts to tackle the hard and abrasive nature of overburden strata. The lignite mining is also faced with adverse hydrological conditions caused by confined aquifer occurring below lignite seam, with an upward thrust of 5 to 8 Kg/cm<sup>2</sup>. The challenges posed by nature on lignite mining were aptly handled in the Neyveli mines by continuously upgrading the technology and capacity of BWEs and by continuously optimizing the Ground water pumping pattern. Initially smaller capacity 350 litre BWEs with 1000 mm fabric belt conveyors deployed were upgraded to 1400 litre Bridge type BWEs and 2400 mm steel cord belt conveyors, to augment the lignite production from 3.5 MT/Annum to 31 MT/Annum. A blackish alluvial clay formation occurs just below the surface in Mine-II which when wet causes choking of buckets affecting the free discharge of overburden from buckets. Several modifications were introduced in the buckets to overcome this problem. Over the years NLC, has evolved the Ground Water Control pumping in mines by making concerted efforts towards optimizing the pumping operations. NLC is expanding Mine-II from 10.5 MT/Annum to 15 MT/Annum with introduction of BWEs and conveyors with state-of-art technologies like Programmable Logical Circuits for easy fault diagnosis, Variable Voltage Variable Frequency drives, automation of excavation operations etc. The paper traces the history of these developments introduced in lignite mining at Neyveli mines during the past five decades. The present estimated Lignite reserves of 38.75 Billion tonnes in India have the potential to be tapped for sustainable development in future. It is planned to increase the total lignite production of India to 55.0 Million tonnes by 2011–12 and to 88.0 million tones By 2016–17 at a growth rate of 15%. It is projected that the production of Lignite will reach around 150 Million tonnes per year by 2031–32. The paper traces developments on clean coal technologies to be adopted in new blocks and other new lignite mining projects envisaged for attaining the goals set in the Five year plans in India.

9.20 - 9.35 a.m.

N. Valkanov, Iv. Rusinov, N. Bonev, St. Topalov, K. Boev, S. Tokmakchiev  
*Minstroy Holding, University of Mining and Geology, Bulgaria*

**A BILATERAL CONTRACT IN POWER SYSTEM FROM THE EUROPEAN UNION -TASKS, CHALLENGES AND PROGNOSSES**

There is a contract on the technological and technical security of production systems for coal extraction from the Maritsa Iztok field concluded by and between Bulgaria and Poland. The tasks, challenges and prognoses in our joint activity are based on certain clustering. Bilateral projects of a similar kind within the EU will acquire larger scale, significance and social character.

9.40 - 9.55 a.m.

S. Strunk, *RWE Power – Open cast mine Hambach, Germany*

**OPTIMIZING THE PRODUCTION OF PROBLEMATIC OVERBURDEN AT THE HAMBACH OPENCAST MINE**

At the Hambach opencast mine the composition of the overburden changed with the advance of mining activity into new grounds: on some benches the amount of unstable soils (difficult to transport and deposit) increased, on other benches hard concretions (difficult to excavate) appeared and at present form extensive clay ironstone horizons. Mining, transport and deposit of these two kinds of materials are the challenges the Hambach opencast mine presently faces. The management of unstable soils has become very complex from a planning and an operational point of view. Furthermore, the large amounts of unstable soils that need to be deposited on this dump may not affect its stability. Finally, clay layers in which hard siderite concretions occur decrease the productivity of bucket wheel excavators and cause damage to these excavators and the downstream conveyor belts. The results of the research and development at Hambach focussing on these issues will be highlighted.

10.00 - 10.15 a.m.

L. Jurdziaik, *Wroclaw University of Technology, Poland*

**BILATERAL MONOPOLY OF A LIGNITE MINE AND A POWER PLANT IN THE SHORT RUN**

It has been shown that there is the optimal solution (maximising joint profits) for bilateral monopoly (BM) of a lignite mine and a power plant in the long run. Realisation of this strategy is best secured by vertical integration. However there is no simple transmission of results to shorter periods. Therefore there is a need to analyse BM operations on the annual basis and find out if also in the short run there is an inherent conflict of individual and group rationality as for the long run. It is also interesting to check out if the double marginalisation problem has an influence on their relations.

10.20 - 10.40 a.m.

Coffee break

10.45 - 11.00 a.m.

D. Fodor, M.Lazar & I. Rotunjanu, V.O. Scortariu, N. Popescu, *University of Petrosani, Romania*

**EXPLOITATION AND REVALUATION OF LIGNITE DEPOSITS IN OLTENIA**

Romania has rich and various useful minerals deposits among which a special mention refer to the lignite deposits. The paper presents the Romanian electric power production and the contribution of the lignite to its production. Also it describes the Romanian lignite deposits, their production and distribution by mining basins and thermal power plants. The most important lignite deposits of the country are located in Oltenia region. In this region there have been implemented the largest open cast projects and underground mines and the working techniques, their machine and equipment endowment, production rates, productivity and costs are considered in the present document. The final part of the paper de-

scribes the problems the specialists face in relation with the mining process itself as well as the future trends of this raw material exploitation and beneficiation in Romania.

11.05 - 11.20 a.m.

S. Ya. Levenson, L. I. Gendlina, Yu. I. Eremenko, *Institute of Mining, Siberian Branch, Russian Academy of Sciences, Russia*

**OPERATIONAL BACK-GROUND AND THE OUTLOOK FOR THE VIBRATION MACHINE EQUIPPED WITH AN ELASTIC EXECUTOR IN THE MINING INDUSTRY**

The mineral mining process charts far and wide take advantage of the vibration feeders, where a sizeable proportion is occupied by the machines with an elastic executor, vibrating carpets. The vibrating carpets have serviced in the open mining, in loading units of quarries and on dumping. A promising trend for the vibrating carpets is conveying resistant materials such as clayey, sticky and caking materials from storage capacities. Growing volumes of mineral extraction and beneficiation have predetermined the birth of vibrating feeders for transportation of materials from storage reservoirs: ore chutes, blocks, bunkers. Vibration machines are advantageous for simple design and handling, relatively low cost both of the machine itself and of its installation, sufficiently high production output and safety; by virtue of which they are widely used in the mining, construction, chemical and other industries. A particular place among vibrating feeders belongs to a vibrating device equipped with an elastic executor that moves wave-like, developed at the Institute of Mining SB RAS.

11.25 - 11.40 a.m.

A. R. Mattis, V. I. Cheskidov, V. N. Labutin And G. D. Zaitsev, A.A. Kragel, *Institute of Mining, Siberian Branch, Russian Academy of Sciences, Russia*

**BLAST-FREE TECHNOLOGY FOR OPENCAST MINING TECHNIQUE AND AREA OF EFFECTIVE APPLICATION**

Nowadays countries with the advanced mining industry are more and more being interested in the blast-free quarrying rather than in the conventional drilling-and-blasting procedure that is used for rock mass development. In this respect, three scientific institutions incorporated in the Siberian and Ural Branches of the Russian Academy of Sciences, launched an integration project devoted to the feasibility evaluation of the most promising methods of rock destruction, trends of new equipment manufacturing for blast-free technology implementation, analysis of the existing machinery and effective ranges of application of this technology in terms of the Ural and Siberian deposits (Mattis, 2007). The content of this project is the basis of the given paper.

11.45 - 12.00 a.m.

A. Ekrem Yüce, Fırat Burat, Fırat Karakaş, Mustafa Özer, Vecihi Gürkan, Güven Önal, *Istanbul Technical University, Turkey*

**RECOVERY OF NICKEL AND IRON FROM ALBENIAN LATERITIC FE-NI ORE**

Low grade nickel ores containing large amounts of serpentine minerals have historically been difficult to process efficiently. The four major commercial routes that have been used for processing nickel laterite ores are ferronickel smelting, matte smelting, the reduction roast/ammoniacal leaching process known as Caron process and pressure acid leaching (PAL). As an alternative process route to recover of nickel is atmospheric acidic leaching of the ore and can be applied economically in industrial scales. The heap leach method comprises leaching of the ore with dilute sulphuric acid at ambient temperature. In this paper, leachability of nickel and iron were investigated by direct agitation leach and pugging following leaching of both metals. Metal content of run off-mine ore used in this study are 0,934% Ni and 49,50% Fe. Main target in the direct leaching tests at elevated temperature was to obtain higher nickel and

## SESSSION 8

21st World Mining Congress, 7-11.09.2008, Kraków, Poland

lower iron dissolution recoveries. At least 80% nickel extraction was expected while iron extraction would be less than 20%. In this case, although acid consumption is reasonable lower, unfortunately, no success was obtained in terms of extraction recoveries. As a second alternative to the abovementioned process, acid pugging following leaching tests at elevated temperature were conducted. According to the optimum test results, nickel and iron extraction recoveries were 92,7% and 80,6% respectively. Leach residue was removed with 0,216% Ni and 30,54% Fe content. At the end of leaching of the ore, acid consumption was calculated as 480 kg per ton of ore.

12.05 - 12.20 p.m.

Admir Softic, Suncica Masic, Zahid Basic, Amir Brigic, *Brown Coal Mining Company Banovici, Bosnia and Herzegovina*

### **OPTIMUM OF HEIGHT SUPPLYING - HEIGHT OF RE-PUMPING WITH OSCILLATION OF THE SUCTION ALTITUDE AND OSCILLATION OF CAPACITY SIZE OF PUMP IN EXPERIMENTAL EXAMPLE ON THE OPEN PIT «GRIVICE»**

In this work, we presented research results at determining of re-pumping altitude with oscillation of suction altitude and oscillation of capacity size of pump at re-pumping system drainage of deep open pits.

12.20 – 12.40 p.m.

Josef Schild, *Diabaswerk Saalfelden GmbH, Saalfelden, Salzburg, Austria*

### **THE NEW AUSTRIAN DIABASE OPEN PIT PROJECT “TAGBAU 21”**

The paper is about Austrian diabase open pit project called “Tagbau 21”. Autor shows pluses and minuses of this idea. The main attention is concentrated on agreements between the public interest in preserving natural environment and promoting tourism and the public interest in the exploitation of necessary raw materials.

1.50 - 2.50 p.m. Lunch

3.00 - 5.30 p.m.

Visit in Brown Coal Mine BOT KWB S.A. and in Power Plant "Bełchatów"

6.00 - 7.00 p.m.

Dinner

7.30 p.m.

Departure to Krakow

## OUTGOING SESSION

10<sup>th</sup> September 2008  
Day 4 (Wednesday)

The Salt Mine „Wieliczka”  
ul. Daniłowicza 10, Wieliczka

## Organisers of the session



Mineral and Energy Economy Research  
Institute of Polish Academy of Sciences



PRO FUTURO  
Society for the Restoration and Promotion of  
Queen Luise Adit in Zabrze "ProFuturo"

**Session 9: THE MINE AS A WITNESS TO HISTORY  
AND A MONUMENT OF TECHNOLOGY**

Venue: The Salt Mine „Wieliczka”

Chairman: Bronisław Barchański, Co-Chairman: Antoni Jodłowski  
Secretary: Michał Kopacz, Ludomir Wiśniewski

8:30 a.m. Meeting members of the session, Auditorium Maximum UJ, 35 Krupnicza Str.

8:45 a.m. Departure from Kraków

9.45 a.m. Transportation to Drozdowice 4 Chamber

10.15 a.m. Opening of the session

**Part 1 - 10.30 - 12.00**

10.30 - 10.45 a.m.

Zbigniew Zarębski, *Wieliczka Salt Mine PLC, Poland*

**THE WIELICZKA SALT MINE**

The Wieliczka Salt Mine is the oldest production company in Poland and one of the oldest in Europe. The oldest in Europe, complete salt-making records found in Barycz dating back 6 thousand years ago signify the thousands years of the salt mining tradition in the Wieliczka region. The historical beginnings of the mine itself date back to the medieval times when it was proudly named Magnum Sal – Great Salt.

10.45 - 11.00 a.m.

Adam Frużyński, *Coal Mining Museum in Zabrze, Poland*

**A COLLECTION OF PLANS AND TECHNICAL DRAWINGS OF STATE MINING  
AUTHORITY FROM WROCLAW AS A SOURCE TO MINING HISTORY ON  
UPPER SILESIA AT THE TURNOVER OF 18TH AND 19TH CENTURY**

This paper is devoted to presentation of a collection of plans and technical drawings, being one of the most important sources of information concerning the history of Upper Silesian mining at the turn of 18th and 19th centuries. At present, they are stored in the Archives of Historical Department and Mining Technique of Museum of Coal Mining in Zabrze.

11.00 - 11.15 a.m.

Eufrozyna Piątek

**THE TOWN OF WAŁBRZYCH FROM THE POINT OF VIEW OF THE MINING INDUSTRY DEVELOPMENT**

The article is an attempt to analyse the interrelations between the town development and coal mining as well as the significance of other industrial branches which developed owing to the abundance of coal and the products of which satisfied among others the needs of the local mining industry and inhabitants. The attention was paid not only to the statistical and structural image of the town, but also to its ever-changing social and living conditions. As the assumed size of the article and the adopted time framework do not allow a detailed presentation of all the issues, the article has been limited to a survey of the above mentioned phenomena, especially that the source material is scant and the number of studies limited. The aim of the paper is to present characteristic features of the town of Wałbrzych as an industrial centre based on coal deposits. In the studies published so far a quantitative approach to the urbanisation process may be observed; the man as a person, a subject is neglected and becomes lost in a statistical mass confronted with the automatism of objective technical and social changes.

11.15 - 11.30 a.m.

Jerzy Tomasz Bąbel, "Krzemionki Opatowskie" Archaeological Museum and Reserve "Krzemionki Opatowskie", Poland

**THE EARLIEST BEGINNINGS OF MODERN MINING**

In the region of Świętokrzyskie Mountains, there are outcrops of various types of flint and numerous prehistorical mines. One of the largest locations of this type in Europe is a relatively best known monument of prehistorical mining art, in the current "Krzemionki Opatowskie" Archaeological and Nature Reserve near Ostrowiec Świętokrzyski, Świętokrzyskie voivodeship.

11.30 - 11.45 a.m.

Gennadiy Gayko, *Donbass State Technical University Alchevsk, Ukraine*

**MINING ENGINEERING IN THE HISTORY OF CULTURE AND ENGINEERING (REFLECTIONS UPON THE EXPECTANT BOOK PAGES)**

It is determined the problem of inadequacy of mining engineering role with its share in the information area and historical science. It is shown the basic role of mining engineering in formation of technological and cultural parts of human civilization. It was studied the problem of metal development as the key stage of historical movement. It is substantiated the hypothesis of discovering metals by clans of ancient miners. There were noticed the important technical achievements, connected with mining engineering technologies. It is shown the topicality of basic textbook on the history of mining engineering for technical universities of European countries.

11.45 - 12.00 a.m.

Ludomir Wiśniewski, Jan Gustaw Jurkiewicz, *Society for the Restoration and Promotion of Queen Luise Adit in Zabrze "ProFuturo"*

**THE MAIN HEREDITARY KEY ADIT A TESTIMONY TO THE DEVELOPMENT OF UNDERGROUND BUILDING TECHNOLOGY IN THE 18TH/19TH CENTURY**

The development of hard coal mining in the region of Zabrze was connected with the activities of Prussian authorities, which having conquered Silesia became interested in its mineral resources, especially the ores of silver and lead near Tarnowskie Góry. Lead was necessary for the production of ammunition, while silver was to supply the state treasury. The development of a new ore mine and steelworks in Strzybnica required hard coal, which was used as a fuel in metallurgical furnaces and put in motion the drainage steam pumps of the mine ....

12.00 - 1.30 a.m. Lunch



**Part 2 - 1.30 - 3.00**

1.30 - 1.45 p.m.

Antoni Jodłowski, *Museum of Cracow's Saltworks, Poland***SALT MINE IN WIELICZKA - A HISTORICAL REMAIN OF MATERIAL CULTURE AND A HISTORY WITNESS**

Among old mining canthers of Europe, a special place is taken by Wieliczka salt mine, which is functioning all the time from the second half of thirteenth century until these days. Until 1772, it constituted – together with a neighbouring Bochnia salt mine – one big industrial enterprise (the biggest in Poland before the partitions) called Cracow saltworks, being the royal property, which during the medieval ages delivered about 1/3 of all the income to the then state treasury. After over 700 years of intensive exploitation, Wieliczka salt mine constitutes currently in its greater part a historic object of high historic value as a unique reserve and mining heritage park in the world ...

1.45 - 2.00 p.m.

Zenon Szmidtke, *The Coal Mining Museum in Zabrze, Poland***SKARBOFERM - 1922-1939. TECHNICAL AND TECHNOLOGICAL INNOVATIONS INTRODUCED BY THE CONCERN AND ITS EXPANSION ON GLOBAL MARKETS**

Skarboferm is an abbreviated name of a Polish-French company leasing state coal mines in the Upper Silesia, taken over by the Polish government from the Prussian authority. Its full name read: Polskie Kopalnie Skarbowe in the Upper Silesia, Lease Company, Stock Company in Katowice (Société Ferrière des Mines Fiscales de l'Etat Polonais en Haute-Silésie, Société Anonyme f Katowice) 1. Although it was formally established on 25th February 1922, the agreement concerning its foundation was signed before the plebiscite in the Upper Silesia, that is on 1st March 1921 in Paris. It was an expression of economic concessions made by the Polish government in Upper Silesia for French industry, in exchange for the French support for the matter of Polish national affiliation of the Upper Silesia ...

2.00 - 2.15 p.m.

Piotr Strzałkowski, *Faculty of Mining and Geology Silesian University of Technology, Poland***INFLUENCE OF MINING EXPLOITATION ON SURFACE - EVOLUTION OF VIEWS AND METHODS OF DEFORMATION FORECASTING**

The influence of mining exploitation on surface is the object of interests among the group of specialists in a mining range only about 200 years when the extraction of coal bed under Liege, the town in Belgium was carried out, causing numerous damages to buildings. On the basis of those experiences were created the first, often naïve, methods of forecasting deformation indices after exploitation. Many years of experience as well as careful analysis of measurement results allowed working out a number of mathematical models which are useful in a practical sense. In this work, there are presented computational methods- beginning with those worked out in the nineteenth century and finishing with contemporary ones, which demand the use of digital techniques.

2.15 - 2.30 p.m.

D. Fodor, V. Pop, *University of Petrosani & University of Baia Mare, Romania***PAGES OF ROMANIAN MINING HISTORY**

The paper focused on the beginning and development of the mining activity in Romania. The first part of the paper is a brief but relevant description of the useful mineral exploitation and processing since the Ancient times until the Dacia conquest by the Romans and the mining operation development during the Roman rule. The second part of the paper describes the decrease of the mining operations after the Roman retreat from Dacia and rehabilitation of the mining operations during the Middle Ages, as well as, the mining industry development during capitalism epoch. The third part presents the mining activity

developed after the World War II and the strong restructuring undergone by the Romanian mining industry by the end of the II<sup>nd</sup> Millennium and the beginning of the III<sup>rd</sup> one. The paper provides the mining zones, the useful minerals extracted and rendered valuable as well as the progress of technologies and working techniques or each development stage.

2.30 - 2.45 p.m.

Maciej Madziarz, *Institute of Mining, Wrocław University of Technology, Poland*

**800 YEARS OF MINING IN RADZIMOWICE. FROM A 13TH CENTURY ORE MINE TO URANIUM ORE MINING, AN EXAMPLE OF CENTURIES LONG HISTORY OF THE LOWER SILESIAN ORE MINING DEVELOPMENT**

Lower Silesia has been known for its minerals exploitation for centuries. Gold, ores of silver, lead, copper, tin, arsenic, cobalt, nickel, chromium, iron, uranium, hard coal, brown coal, rock material and even mineral waters were and partially still are a great treasure of this region. The main object of interest of ancient miners were numerous small metal ore deposits exploited periodically from the 13th until the 20th century, which were located in the Sudety Mountains and their piedmonts. The existence of ore in the neighborhood of Radzimowice in the southern part of the Kaczawskie Mountains has been known for a long time. The Stara Góra (Old Mountain) deposit was one of the most important mining centers in Lower Silesia.

2.45 - 3.00 p.m.

Zenon Duda, *AGH University of Science and Technology, Department of Mining and Geoengineering, Poland*

Janusz Wojciech Kotasiak, *The Archeological Museum in Ostrów Świętokrzyski in years 1962 – 2006, Poland*

**THE NEOLITHIC FLINT MINES IN KRZEMIONKI - PROBLEMS OF CONSERVATION AND ADAPTATION FOR DIDACTIC AND TOURISM EXHIBITION**

This article presents the description of mining and conservation works in the ancient flint mine rooted in the Neolithic Age in Krzemionki near Ostrowiec Świętokrzyski. The objective of this work is strictly related to the necessity of tourist safety improvement, resulting from the intensity of tourism movement as well as the necessity of adapting of this natural area to a didactic exhibition. Also presented is the relation of this undertaking within a strict and friendly long-term cooperation between the Archeological Museum in Ostrowiec Świętokrzyski and the University of Science and Technology in Cracow.

3.00 - 3.45 p.m. Coffee break

3.45 - 4.45 p.m.

End session - closing remarks

4.45 - 6.30 p.m.

Visiting the Wieliczka Salt Mine

6.30 p.m.

Departure to Krakow

**OUTGOING SESSION****10<sup>th</sup> September 2008****Day 4 (Wednesday)**

State Mining Authority,

**ul. Poniatowskiego 31, Katowice**

State Mining Authority

Organiser of the session

**Session 10: LEGAL ASPECT OF MINING ACTIVITY**

Venue: State Mining Authority, ul. Poniatowskiego 31, Katowice

Chairman: Piotr Gisman

Co-Chairman: Magdalena Śmieszek, Małgorzata Waksmańska

7.45 a.m. Meeting of the participants at the Main Hall of Auditorium Maximum of the Jagiellonian University, Krupnicza str.

8.00 a.m. Departure to Katowice

10.00 - 10.20 a.m. Opening address by the President of State Mining Authority

**1<sup>st</sup> Part of plenary session 10.20 a.m. – 12.20 p.m.**

10.20 - 10.35 a.m.

Karin Aust, *Federal Ministry of Economics and Labour, Austria***THE SCOPE OF GEOLOGICAL AND MINING LAW**

Before 1999 the mining industry was regulated by two laws: The Mining Act on the one hand and the Trade law that regulated all mineral raw materials not listed in the Mining act on the other hand. Since 1999 all kinds of mineral raw materials are under the jurisdiction of the law on mineral raw materials ("Mineralrohstoffgesetz"). The area of application of the mineral raw materials act refers to the exploration and production of mineral raw materials and the treatment of such substances in as far as carried out by the holder of the mining right title in the course of exploration and production operations. A number of provisions of the mineral raw materials act furthermore refers to the certain activities in as far as mining engineering aspects are concerned (like visitor-mines).

10.35 - 10.50 a.m.

Boris BALOG, *Ministry of Economy, Slovak Republic***CURRENT SITUATION AND PROSPECTS OF SLOVAK MINING LEGISLATION**

The Article deals with the current situation and prospects of Slovak mining legislation. The Article deals with the year 2007, as the National Council of the Slovak Republic adopted a new Geological Act and passed crucial and extensive amendments to both the Mining Act and the Act on Mining Activity.

10.50 - 11.05 a.m.

Simon Cook, *The Coal Authority, Great Britain*

**BACK INTO THE PRIVATE SECTOR - THE REGULATION OF GREAT BRITAIN'S COAL RESOURCE SINCE 1994**

The British coal industry was privatised in 1994 ending a period of 47 years of state ownership. The regulation of the private sector was handed over to the Coal Authority, a non-departmental public body established for the purpose and this paper looks at the function of the Coal Authority relating to the Licensing of the British coal resource. I will begin by providing a brief history of coal ownership and control through the nationalisation of the industry in 1947 to privatisation and the setting up of the Coal Authority in 1994. I will then set out the Coal Authority's statutory duties relating to the licensing of coal, the process by which operators apply for permission and the criteria for determination. I will look at other forms of Authority permissions necessary to access coal when not directly associated with mining activity and outline some of the challenges faced since 1994.

11.05 - 11.20 a.m.

T. Hámor, G. Szabados, *Hungarian Office for Mining and Geology, Hungary*

**AN ASSESSMENT OF FUTURE TRENDS IN MINING AND GEOLOGY LEGISLATION AND ASSOCIATED REGULATORY COMPETENCES**

The significant and rapid changes of the last two decades in the global socio-economic and political environment make decisionmakers to re-consider the mandate and mission of mining and geology related legislation, and the associated regulatory and supporting institutional scheme. This paper is a presentation of the authors' views on the major driving forces and trends of change in this stream of law. It is up to the specific situation in the given country to design how broad regulatory competences shall be defined in the relevant statutory legislation for a mining and geological authority, nevertheless, an array of core competences is shown hereby. The common historical roots, and the natural synergy of mining engineers and geologists via the special blend of scientific and technical professional capacities are potential advantages which were not exploited in the last two decades in a due manner, and which may form a strong basis for the successful future of this sector.

11.20 - 11.35 a.m.

Ilmar Joosepson, *Estonian Technical Surveillance Authority, Estonia*

**THE IMPLEMENTATION OF THE REQUIREMENTS OF ESTONIAN MINING ACT AND DIRECTIVES OF EU IN THE ESTONIAN MINING INDUSTRY**

The main mineral resource in use on the territory of Estonia is Eesti oil shale deposit. EU regulations and national legislation establishes the requirements for the competences of the employees and employers in the field of mining operations, geological explorations and recultivation of extracted areas. The framework EU directive (89/391 EEC) describes the general principles by which these improvements should be achieved and the EU directive 92/104 describes the principles on surface and underground extractive industries. The competences of mining supervision Authority in case of Estonian mining sector includes the mining supervision over the operations of mining technology, blasting and concentration processes. The national Mining Act provides the requirements for mining operations and according to the Earth Crust Act are issued licences for geological explorations. On the bases of the standard OHSAS 18001: 1999 „Occupational health and safety Management systems. Specification“ has been elaborated the national standard „Management systems of OH & S“ focusing on requirements of working environment.

11.35 - 11.50 a.m.

Ryszard Mikosz, *Silesian University, Katowice, Poland*

**The scope of Polish mining and geological law**

The principal aim of this paper is to briefly describe the regulation included in the Geological and Mining Law (Act of February 4th, 1994, Official Journal of 2005, No. 228, Item 1947 with amendments), in particular provisions concerning the scope of its applicability. The analysis shows that this Act regulates

relatively large list of different matters. First of all it specifies the rules and terms of: carrying out of geological works, minerals exploitation from deposits, storing of waste in the subsurface, including underground mining excavations with the exception of such storage in opencast mining excavations, as well as protection of mineral deposits, underground waters and other components of the environment in connection with carrying out of geological works and minerals exploitation. Beside of this the Geological and Mining Law regulates also: ownership and mining usufruct, concessions, relations with neighbours and liability for damage caused by mining plant operations, matters connected with organization and competences of geological administration authorities, state geological survey and mining supervision authorities, as well as penal provisions.

11.50 - 12.05 a.m.

Aleksander Lipiński, *Silesian University, Katowice, Poland*

#### **THE SCOPE OF GEOLOGICAL AND MINING LAW (IN LIGHT OF DRAFT ACT AFTER INTERMINISTERIAL CONSULTATIONS VERSION OF 21 JULY 2008)**

The draft act lays down above all requirements on carrying out geological works, mining of minerals and performance of other kind of activities inside the Earth crust (underground storage, underground disposal, construction and maintenance of some underground facilities). Allowance for the aggregates extraction by natural persons for their own purposes with the exclusion of geological and mining law is one of the crucial changes. Furthermore, facilities and equipment for treatment of the extracted minerals will no more constitute part of a mining plant.

12.05 - 12.20 a.m.

H.S. Welideniya, *Department of Earth Resources Engineering Faculty of Engineering, University of Moratuwa, Sri Lanka*

#### **LEGAL ASPECTS OF MINING INDUSTRY IN SRI LANKA AND REGULATORY PROCEDURES**

Mining licensing procedures and Environmental Impact Assessments (EIA) are well constructed and legislated under Mines and Minerals Act of Sri Lanka. Many government statutory bodies are involved in the licensing process which gives legitimate and exclusive rights for investors and developers to invest in the mineral sector. However there are also certain shortcomings in the EIA procedures which adversely affect project progress. These negative affects are mainly caused by time taken for EIA process, public environmental concerns and exaggeration of environmental effects over project benefits.

12.20 - 12.30 p.m. The presentation of mining exhibition (B. Szygula)

12.30 a.m. - 1.30 p.m. Lunch and the presentation of mining exhibition

#### **1.30 - 4.00 p.m. 2<sup>nd</sup> part of the plenary session**

##### **The competences of the mining supervisory authorities and the mining control authorities**

1.30 - 1.45 p.m.

Reinhard Schmidt, *President des Sachsischen Oberbergamtes, Germany*

#### **THE SETTING UP OF AND DUTIES OF APPROPRIATE MINING AUTHORITIES IN GERMANY**

By the German Federal Mining Act of 1980 the mine supervision is an affair of the federal states. The states realised the operating bodies differently. A number of states annacted the form mining inspectorates to the District Governments. Other States combined the mining inspectorate with the geology survey. The mining authorities formulate mining decrees and technical guidelines, they issue mining concessions and are generally responsible for overseeing and for licensing procedures including occu-

## SESSION 10

21st World Mining Congress, 7-11.09.2008, Kraków, Poland

patational health and safety and environmental protection also for water, mine, waste and immission protection in the field of mining operations.

1.45 - 2.00 p.m.

Karin Aust, *Federal Ministry of Economics and Labour, Austria*

### **COMPETENCES OF MINING SUPERVISION ORGANS AND MINING CONTROL ORGANS IN AUSTRIA**

2.00 - 2.15 p.m.

Julianne Knaul, *State Office for Mining, Geology and Minerals of Brandenburg, Germany*

### **COMPETENCES OF MINING SUPERVISION ORGANS AND MINING CONTROL ORGANS**

Mining authority, Mining Act, duties of supervising, safety measures, integrated pollution prevention and control, control of major accident hazards involving dangerous substances.

2.15 - 2.30 p.m.

Ivo Pěgřímek, Pavel Dvořák, Antonin Taufer, *The Czech Mining Authority, Czech Republic*

### **DUTIES OF MINING ORGANIZATIONS IN ORDER TO MINIMIZE CAUSES THREATENING WORK SAFETY AND THE SPHERE OF AUTHORITY OF THE STATE MINING ADMINISTRATION**

Despite a partial downturn over the years, the mining industry in the Czech Republic still belongs to the key industries of our economy. The very part of the machine industry, some additional industries and citizens depend on mining activities. It is also worth mentioning that the mining industry directly employs over 60 thousand employees.

2.30 - 2.45 p.m.

Y.G. Kale, Ranjan Sahai, C.P. Ambesh, *Indian Bureau of Mines, India*

### **SUSTAINABLE MINERAL DEVELOPMENT - POLICY & REGULATORY APPROACH IN INDIA**

Mining industry is one of the important industrial activities in India contributing significantly for the economic development and growth of the nation. In fact, with its rich and varied mineral resources, India has a long history of mining. It is endowed with variety of mineral resources comprising of fossil fuels, atomic minerals, ferrous and non-ferrous ores, fertilizers, refractory and many other industrial minerals.

2.45 - 3.00 p.m.

J.F. Cronjé, L.J. Van Wyk, C.S. Chenga, D. Van Wyk, L. Segwe

*North-West University Potchefstroom South Africa University of Kent, UK Bench Marks Foundation of Southern Africa, Johannesburg, South Africa Mudjarii Trading (Pt) Ltd., Johannesburg, UK, South Africa*

### **DEVELOPMENT ISSUES WITHIN A CSR FRAMEWORK IN THE SADC**

Mining communities in the Southern African Development Community (SADC) are mainly isolated, originally rural with high illiteracy rates and are very dependent on the mining companies for their livelihood and development. The mining companies are fast growing and are associated with high earnings, which have an impact on the local communities who are usually unable to respond to this across-the-board momentum, because of their rural based background. Consequently, mining communities throughout the region are characterised by poor environmental and social conditions. Globally and nationally, there has been pressure on corporations to behave more socially responsible. Therefore, to

## SESSION 10

21st World Mining Congress, 7-11.09.2008, Kraków, Poland

achieve corporate citizenship companies must be involved in sustainable development of the communities. The aim of this study was to investigate and address different environmental, social and economic developmental issues - against the background of a generally acceptable CSR framework - in three selected SADC countries, namely Malawi, South Africa and Zambia.

3.00 - 3.15 p.m.

A. Kijewska, J. Korski, H. Przybyła, *Silesian University of Technology, Poland*

### **STRATEGIC ROLE OF HUMAN RESOURCE MANAGEMENT IN COAL MINING**

Contemporary strategies of human resources management (HRM) should be based on business partnership and should result from settled business strategy. In strategic HRM we must take into consideration the activities that are directed to recruiting and retaining such employees, who will be working for the enterprise success and that are directed to increase in staff participation and involvement in the enterprise matters. Such activities are not observed today in coal mines although they are essential for continuous, uninterrupted functioning of coal mines, employee safety and required economic results. The attempt of solving problems to employ in coal mine proper quantity of people with adequately education in order to achieve organizational success has been presented.

3.15 - 3.30 p.m.

K.Gadowska, J.Martyka, K.Nowak, K.Tausz, *Jagiellonian University, Poland*

### **REFLECTION ON THE PRESTIGE OF MINE SUPERVISORY STAFF FROM THE ASPECT OF HARD COAL MINE MANAGEMENT**

The paper is devoted to the social prestige attributed to a specific category of managers – mine supervisory staff (mine officials). The mine supervisory staff is a large professional group constituting a hierarchised mine management structure; a group that should not only manage the production tasks but also participate in the planning of changes (and manage these changes) leading to the organisational and technical modernisation as well as economic effectiveness of individual mines and the mining sector as a whole. The participation of the mine supervisory staff in these activities has impact on their course (in the sense of the rate and scope of changes), and the dimension of prestige attributed to this group can strengthen or weaken the reliability of processes mentioned above. The data mentioned in the paper relating to the dimension of prestige attributed to the mine supervisory staff, its determinants and implications originate from a sociological survey conducted in 2007 among workers and underground mine supervisory staff of hard coal mines and students of two technical universities. The survey covered 230 underground workers, 90 underground supervisory staff of a hard coal mine, 48 last-year students before graduation of the Mining Engineering and Geology Department of the Silesian Technical University in Gliwice and 66 students of Department of Geology, Geophysics and Environmental Protection of the AGH University of Science and Technology in Cracow

3.30 - 3.45 p.m.

Piotr Gisman, *State Mining Authority, Katowice, Poland*

### **MINING SUPERVISION IN POLAND**

Presented on the basis of the brief description of the history of the legal regulations concerning the mining industry is the evolution of the state mining supervision functioning in Poland. The study contains a detailed description of the current tasks and entitlements of the mining authorities specified in the geological and mining law.

3.45 - 4.00 p.m. Discussion and closure of the session

4.10 - 4.30 p.m. Departure to the historic mine „GUIDO” in Zabrze

4.30 - 8.30 p.m. Visit to the historic mine „GUIDO” and mining fest

8.30 p.m. Departure from Zabrze to Krakow

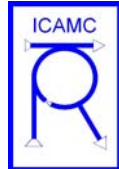
**SATELLITE SESSION****10<sup>th</sup> September 2008****Day 4 (Wednesday)****Main Hall A-0,****AGH University of Science and Technology****Al. Mickiewicza 30****Session 11****17<sup>TH</sup> INTERNATIONAL CONFERENCE ON AUTOMATION IN  
MINING ICAMC`2008**venue: Main Hall A-0, AGH University of Science and Technology,  
Ave. Mickiewicza 30

Chairman: A.K. GHOSE, Co- Chairman: Bolesław FIRGANEK

Secretary: Elżbieta ŚWIDER

9.00 – 9.10 a.m. Conference opening

Section I: Control Systems;  
Chairman Prof. A.K. Ghose

9.10-9.30 a.m.

A. Czechowski, M. Lubryka, J. Lubryka, *Elgór+Hansen, JSW S.A- KWK „Jas-Mos”,  
Poland***THE STUDY OF CONTROL SOFTWARE: SYSTEM AND VISUALIZATION FOR  
SPECIAL MINING MACHINE**

This paper presents the study of control software system and visualization for prototypical hardrock-miner, special mining machine. It introduces some selected issues relate to software design, model and the analysis of special mining machine control system working which interacts with frequency converters. The design and the implementation of the management system for such advanced equipment is not an easy task. The system is assumed to analyze multiple relationships, there must be anticipated the highest possible number of cases, situations and statuses of the machine itself, as well as very difficult surrounding environment. The developed software was applied in special mining machine, the ADS Hardrockminer 2006 by Bucyrus-DBT during the exploitation in a platinum mine in the Republic of South Africa, and met the expectations. The structure of the algorithm and the parameterization of the adjustment system were adapted to the dynamic properties of the special mining machine's working components. In similar solutions with application of a remotely controlled special mining machine interest the Jastrzębie Coal Company coal mines where there appears the problem of exploitation of deposits parts of irregular shapes with a use of short main walls. The direct extension of the issues discussed in this paper may be the concept of adaptive control utilizing the phenomenon of learning by artificial neural networks. This issue would require extensive recording and analyses of operation of identical special mining machines in various mining conditions in order to obtain sufficiently large amount of representative data that could form grounds for learning by fuzzy neural networks. The system is divided into two parts created in two collaborating software development environments by KW Software®. The visualization of the special mining machine and the process was created in ProVisIT® and the control application in Multiprog® environment.



9.30-9.50 a.m.

K. Opielka, J. Zientek, A. Jestratjew, W. Domagała, R. Makowski, A. Nowakowski, A. Bywalec, *Silesian University of Technology Department of Computer Science, Poland*

#### **SUPERVISORY CONTROL SYSTEM FOR MINING BELT CONVEYORS**

We present an architecture and implementation of a supervisory control system for a mining conveyor belts system. The control system is built of a set of programmable controllers local to each conveyor and a PC computer located on the surface. Local programmable controllers continuously monitor conveyor working conditions, control the conveyor and provide a user with an interface for parameters check and commands. The PC computer is connected with programmable controllers by specialized computer network. It runs a specialized SCADA (Supervisory Control And Data Acquisition) application responsible for central data acquisition and remote control of the conveyors. It also acts as a gateway that enables authorized users to monitor alarms and events data by local area network (LAN) or the Internet.

9.50-10.10 a.m.

E. Cieślak, A. Holik, *Elektrometal S.A., Poland*

#### **MEMORY MANAGEMENT IN ANNOUNCEMENT MODULE EM250 OF ELSAP-05 INTRINSICALLY SAFE CONTROLLER**

The paper describes general design of ELSAP-05 intrinsically safe controller. Available busses, modules, networking concepts and software tools are discussed. The memory map and its usage is shown in detail for EM250 voice announcement module. Memory is divided in fixed size blocks and the blocks are organized in lists. The size of block in a list is discussed. Other solutions of memory map organization and its efficiency is also presented. The configuration software is also presented. Its basic features are described.

10.10-10.30 a.m.

Z. Kasztelewicz, J. Szymański, *AGH University of Science and Technology, Poland*

#### **CONTROL OF THE CONVEYOR BELT AND CATERPILLAR MACHINES DRIVES IN THE BROWN COAL MINES**

In the paper aspects of a proper choice of the power converter and proper control method in order to achieve synchronized work of motors in the excavator, spreader and conveyor drives are presented. Control methods which were used assure high efficiency and equal load sharing in static and dynamic states. Energy saving squirrel cage motors which were used in these applications are controlled by means of scalar and vector control methods. The drive system is fed from low voltage IT mains. Mining machines which use described control methods are more commonly used in polish Konin and Belchatow brown coal mines.

10.30.-11.00 a.m. Coffee break

### **Section II: Safety and Communication; Chairman Prof. S. Cierpisz**

11.00-11.20 a.m.

Ch. Muller, *Embigence GmbH, Germany*

#### **UNDERGROUND MINE NETWORK COMMUNICATION: ADDING MINING SPECIFIC VALUE BY UNIFIED COMMUNICATION INFRASTRUCTURE**

For modern underground mine communication, today systems basing on the Ethernet standard are used. Even if such networks are used as the only underground communication system, they require a substantial investment into passive and active components distributed in the mine. The return on in-

vestment for this infrastructure can be increased by adding mining specific value to the underground network infrastructure thereby saving cost and maintenance effort for equipment and systems which otherwise would have to be purchased separately. This paper points out the mining specific added value of underground network installations and the benefits such integrative systems have for overall optimization of underground mining processes.

11.20-11.40 a.m.

K. Miśkiewicz, A. Wojaczek, *Silesian University of Technology, Gliwice, Poland*

#### **MINING COMMUNICATION SYSTEMS INTEGRATION**

Structures of mining telephone communication and alarm-broadcasting system used in Polish mines have been discussed. Integration opportunities have been presented of various communication systems. PABX telephone exchange integration has been suggested as well as alarm exchange and creation of uniform mining telecommunication system, which shall accomplish telephone communication functions as well as alarm-broadcasting ones.

11.40-12.00 a.m.

H. Passia<sup>\*</sup>, W. Skoropacki<sup>\*</sup>, F. Świergot<sup>\*\*</sup>, *Central Mining Institute, Katowice, Poland*, *Mining Electronics Factory „ZEG”, Tychy, Poland*

#### **IDEA OF EXPLOSION-PROOF POWER SUPPLY BUS INTENDED FOR CONTINUOUS WORK IN ATMOSPHERES ENDANGERED WITH EXPLOSION OF METHANE AND/OR COAL DUST**

The papers deals with presentation a conception of a remote power supply bus, which is able to transmit simultaneously both intrinsically safe power and informative signals using typical mining telecommunication cables.

12.00-12.20 p.m.

L.K. Bandyopadhyay, S.K. Chaulya, P.K. Mishra, *Central Institute of Mining and Fuel Research, India*

#### **DEVELOPMENT OF TRACKING AND MONITORING SYSTEM BASED ON RFID TAGS FOR DISASTER MANAGEMENT IN UNDERGROUND MINES**

A radio frequency identification (RFID) based wireless mine tracking and monitoring system based on IEEE802.15.4 mesh network has been developed. The paper describes briefly the different hardware and software modules of the developed system and some field trial experiences at underground mines.

12.20-12.40 p.m.

K. Miśkiewicz, E. Cieślak, *Silesian University of Technology, Elektrometal S.A., Poland*

#### **SELECTED PROBLEMS WITH LOCATION OF TRAPPED MINERS IN UNDERGROUND MINES**

Location of a trapped miner is a significant element of some rescue operations in underground mines. For the location needs the miners are equipped with location transmitters, which are the source of magnetic field in the form of magnetic dipole, with magnetic moment of 0.08 Am<sup>2</sup>. Location transmitter is an element of a cap lamp. The location receiver (with antenna), which is used to localize the location transmitter, measures the value of magnetic field produced by location transmitter. The position of location transmitter is determined on the basis of magnetic field strength value (H) and by applying of appropriate measuring procedures. The rules of location are presented in this report. Location uncertainty has been determined with using of new, digital location receiver MinSearch-08, developed by Elektrometal S.A. Company.

12.40-1.00 p.m.

P. Golicz, *Central Mines Rescue Station, Poland*

**GLON-GLOP MINING SYSTEM FOR LOCATING PEOPLE CAPTURED BY FALL OF THE ROOF**

The operating principle and technical parameters of the system for locating miners, used in Polish coal mines, and the methods for testing transmitters have been described. The system, based on equipping each miner with a GLON transmitter, operating in the myriameter wavelength range (VLF), was developed in Poland in the 70-ties and is broadly (and obligatorily) used in coal mines. The operating principle involves the measurement of the intensity of magnetic field generated by a transmitter incorporated in miner's lamp. Proper selection of the operating frequency and the transmitter design allow to determine the distance between the transmitter and GLOP receiver (i.e. between the miner and rescuer) with the accuracy of around 10%, within the range of 2–25 m.

1.00-3.00 p.m. Lunch

Restaurant Hall (Level -1), Auditorium Maximum of the Jagiellonian University (35 Krupnicza str.)

**Section III: Monitoring Systems;  
Chairman Prof. V. Strakoš**

3.00-3.40 p.m.

E.S. Lapin, V.V. Matveev, M.I. Abdrakhmanov, M.G. Sopochnikov, *Ural State Mining University, Russia*

**THE PROBLEMS OF AUTOMATION OF EXPLOSIVE GAS WITHDRAWAL COMPLEXES IN MINES**

To provide the safe content of explosive gases in mine atmosphere two main methods of preventing penetration of explosive gases from rock masses into mine workings are used. They are the method of degassing and the combined method of airing (ventilation). To solve these problems different technical complexes (systems) of withdrawing explosive gases are used, they being groundbased and mobile degassing and gas-suction plants. The report presents brief outlines of controlled units and requirements for automation systems.

S.O. Kuzmenko, A.V. Vilgelm, S.E. Lapin, *Ural State Mining University, Russia*

**ANALYSIS AND FORECAST SAFETY THREATS AT MINING ENTERPRISES**

The article is devoted to the problem of analyzing and forecasting mine-technological unit state by wavelet-transformation method in data processing. The issues under consideration are methods of analyzing various technological factors' influence upon major characteristics of industrial safety at a mining-technological enterprise. The analysis is based on the use of weight coefficients characterizing how various factors influence a particular operating feature.

A. Babienko, S. Orzehehovsky, S.E. Lapin, L. Kulin, *Ural State Mining University, Russia*

**MINING SAFETY INCREASE BY MEANS OF INTEGRATED IMPLEMENTATION OF REQUIREMENTS FOR GAS CONTROL AND PERSONAL EQUIPMENT OF MINERS**

The authors analyze a possibility of integrated implementation of requirements for staff location surveillance, emergency warning and people search while accident, mine air control providing mining safety increase in coal mines. The principles of the development of an integrated system of accident prevention and technical facilities allowing implementing the suggested approach are worked out.

S. Skobtsov, D. Reshetnikov, E.S. Lapin, *Russia*

**MINE SOURCE OF SUPPLY**

In the article the authors present results of development of power supply devices set for mine measuring, monitoring and information systems, systems of mine automation, warning and communication. The concept of organization of a complex power supply is given, main requirements to parameters are settled both from the side of switching to industrial networks and from the side of switching in loads.

3.40.-4.00 p.m.

S. Peters, T. Gorka, *DMT GmbH, Germany*

**MONITORING OF THE ROOF ROCKS OF ROADWAYS IN UNDERGROUND COAL MINING WITH THE ANCHOR BOREHOLE INSPECTION TOOL**

The Anchor Borehole Inspection Tool is an instrument designed for the optical digital survey of the walls of short slim boreholes. The monitoring of the roof rocks allows the convergence control and the systematic inspection of damages of the roadway support. The Anchor Borehole Inspection Tool offers relevant advantages by its speedy and cost-efficient method of evaluating the rock mass parameters with relevance to safety and guaranties an objective documentation during roadway driving.

**Section IV: Modelling and Optimization;**

**Chairman Prof. E. Lapin**

4.00-4.30 S. p.m.

Cierpisz, K. Kalinowski, R. Kaula, J. Pielot, *Silesian University of Technology, Poland*

**PRODUCTION CONTROL AND OPTIMISATION IN A GROUP OF COAL PREPARATION PLANTS**

A simulation analysis of the production of various steam coal blends and coal concentrates by several coal preparation plants to supply several clients is presented. The aim of the simulation was to find the best combination of washed and unwashed fine coal in each plant and the best mix of products that matches client's preferences. The optimization criterion was to provide the maximum overall tonnage of concentrates of required quality at the constant overall tonnage of the blend.

4.30 - 5.00 p.m. Coffee break

**Section IV: Continuation**

5.00-5.20 p.m.

Z. Neustupa, N. Zdeněk, B. Stalmachová, R. Klimunda, *Czech Republic*

**THE INFORMATION SYSTEM AND MODELLING OF RECLAMATION OF SUBSIDENCE PONDS AND SETTLING LAGOONS IN THE UPPER SILESIA MINING LANDSCAPE.**

A simulation analysis of the production of various steam coal blends and coal concentrates by several coal preparation plants to supply several clients is presented. The aim of the simulation was to find the best combination of washed and unwashed fine coal in each plant and the best mix of products that matches client's preferences. The optimization criterion was to provide the maximum overall tonnage of concentrates of required quality at the constant overall tonnage of the blend.

5.20-5.40 p.m.

M. Karamoozian, S.Z. Shafei, R. Kakai, *Kerman University of Applied Science and Tehnology, Iran*

**SEMIAUTOGENOUS MILL LINER WEAR KINETICS MODEL**

Liner condition is the main factor that influences the availability of the industrial semiautogenous (SAG) mill. Therefore having a mathematical model that can determine the liner conditions is very important. In this study, a method was proposed and tested to make a mathematical model for determination of SAG mill liner wear. It was found that a first order kinetics model could well be used to describe the loss of liner thickness over time ( $R^2 = 0.955$ ). The model is an exponential formula that is based on the wear rate constant ( $k$ ) and operating time. To determine the rate constant and also to examine the validity of the first order kinetics model, the normalized liner thickness versus operating time was drawn in a log-normal graph. This model could calculate the liner thickness at any given time.

5.40 – 6.00 p.m.

T. Niedoba, *AGH University of Science and Technology, Poland*

**APPROXIMATION OF OPARTICLE SIZE COMPOSITION CURVES BY BAYESIAN ESTIMATORS OF WEIBULL DISTRIBUTION FUNCTIONAL PARAMETERS WITH APPLICATION OF CUT NORMAL DISTRIBUTION FUNCTION**

The comminution products are often the sub-products or final products in mineral processing system. As for every product, the very important thing is its quality. In case of the grained materials, one of the most important features describing the product is its particle size distribution. Very often, it determines its adequacy for certain applications, as well the economical effects depend highly of the quality of the product. That is why, the correct evaluation of the particle size distribution is so important. One of the most popular, traditional statistical distribution functions being applied to that purpose is Weibull distribution function (called also Rosin-Rammler-Bennett distribution function – RRB). Usually, the parameters of that function, namely shape and scale parameters, are being calculated by the least squared method and linearization. However, not always the given results are obtained with satisfying level of fitting to the empirical data. The author propose the method based on Bayes theorem to estimate the parameters of Weibull distribution functions (so-called Bayesian estimators), applying the cut normal distribution function to this purpose. It was done on the basis of the results of porphyry crushing in jaw crusher, which were obtained by 10-stageous process. For each stage of crushing, the feed was the product from the previous one. The author chose one of the stages, for which the approximation of the Weibull particle size distribution function was the worst fitted to the empirical data. For this case, the method of Bayesian estimators was applied to estimate the parameters of Weibull function. The statistical verification of the given results was done on the basis of mean squared error factor, which compares the results given by approximation with the empirical data. The selected method should be applied when the simpler methods fail and the results cannot be easily approximated by the ordinary methods, like linearization.

6.00 p.m. Closing of the Conference

8.00 p.m.

Banquet at Auditorium Maximum Jagiellonian University, Krupnicza str., Restaurant Hall (Level -1)

**SATELLITE SESSION**10<sup>th</sup> September 2008

Day 4 (Wednesday)

MH A - A Part of Middle Hall in AM

Auditorium Maximum of Jagiellonian University,

35 Krupnicza str

Organisers

AGH University  
of Science and TechnologyInternational Society  
for Mine Surveying**Session 12****RISK MANAGEMENT & SUBSIDENCE ENGINEERING**

Venue: A Part of Middle Hall in Auditorium Maximum

Chairman: Axel Preusse, Co- Chairman: Ryszard Hejmanowski  
Secretary: Agnieszka Malinowska

9.00 - 9.05 Opening of the session

9.05 - 9.45 a.m.

Axel Preusse - keynote speaker, Anton Sroka, *RAG Aktiengesellschaft, Germany***FUTURE DEMANDS ON MINING SUBSIDENCE ENGINEERING IN THEORY AND PRACTICE**

On the basis of the Law on Financing Hard Coal Mining dated 28 December 2007, the subsidized German hard coal mining industry will be shut down to the end of the year 2018 in a socially acceptable manner; in 2012 this decision will be reassessed. Even after the abandonment of all mining activities subsequent burdens are inevitable. In this paper, the possible long-term effects resulting from a mining industry history, which is spanning more than 200 years, and their possible consequences are pointed out, in particular in connection with the abandonment of mine water drainage measures which is economically meaningful in the long term. According to the decision situation as it presents itself today, this point in time will be far beyond 2018. However, with the planned shutdown of the subsidized German hard coal mining industry the tasks of mining subsidence engineering will change. 9.45 - 10.00 a.m.

9.45 – 10.00 a.m.

Zenon Pilecki, *AGH University of Science and Technology, Poland***THE ROLE OF GEOPHYSICAL METHODS IN THE ESTIMATION OF SINKHOLE THREAT IN THE POST-MINING AREAS OF SHALLOW EXPLOITATION IN THE UPPER SILESIA COAL BASIN, POLAND**

The main aim of the paper is to present a methodology for recognition of destructive processes induced by voids and loosening zone in rock mass by geophysical methods. That recognition has a particular

meaning in the estimation of sinkhole threat in the areas of post-mining exploitation of different deposits. Presence of a non back-filled void or discontinuity induced by mining creates unspecified in time risk for the surface area. Discontinuous deformations occur not always over the area where shallow deposit exploitation took place. Time and place of their occurrence are difficult to predict. Deformations observed till now in areas of shallow exploitation in GZW (Upper Silesian Coal Basin) and Olkusz region occurred shortly after mining activities closing and, as late as, over hundred years after. 39 Geophysical researches, because of their measurement and interpretation capabilities, require distinct changes in physical properties of a rock mass. Those changes should be greater than errors and uncertainties of measurements carried out in particular conditions. The theoretical basis of geophysical recognition has been presented in the paper, as well as examples of that method use in the area of Upper Silesian Coal Basin in Poland. Specific features of geophysical investigations with reference to their measurement and interpretation possibilities are discussed. The methodology for recognition of the degree and range of terrain surface threat with discontinuous deformations in post-mining areas has been presented. This method consists in carrying out appropriately designed geophysical investigations and their control by means of drillings and special measurements in the borehole. The paper presents detailed methodology for selected geophysical measurements performed in geological- -mining conditions of the GZW. The effect of geophysical work consists of as wide as possible information acquisition, which is to be used for optimal designing of subsurface protection in the areas of shallow mining threatened with discontinuous deformations.

10.00- 10.15 a.m.

V. Sokoła-Szewiła, *The Silesian University of Technology, Poland*

#### **METHOD OF EVALUATING THE PROBABILITY OF A STRONG TREMOR**

The method of evaluating the probability of a strong tremor using the relationship between the size of the ground surface deformation and recorded seismic activity of a rock mass. Seismicity induced by conducted mining was characterized by total seismic energy of the tremors  $E$  and the number of tremors  $N$ . The assumption was made that there is a relationship between the volume of the subsiding through created on the surface and observed seismicity of a rock mass. The cross-section area  $P_w$  of the subsiding through along the observation line situated parallel to the direction of an advancing wall front was assumed as an index of the deformation of the ground surface in the model. The method described uses a logit model. The total seismic energy  $E_i$  recorded in time-periods of realized geodesic surveying was used in the model, on the basis of the results, in which the  $P_w$  was determined. It was assumed that the seismic energy which should be released is proportional to the increasing area  $P_w$ . The aim of the evaluation is to determine the probability of a strong tremor occurrence on the basis of the increasing area  $P_w$  and  $E_i$  (total seismic energy released in  $i$  time-period of realized periodical geodesic levelling surveying). It was assumed that the relationship will be searched that will allow us to calculate the probability of a strong tremor with the energy of the order of above  $5 \cdot 10^4$  [J] on the basis of the determined logit model. The relationship between the occurring frequency of particular values of the dependent variable and the selected independent variables was described in the model. The method was applied for the set of observations obtained as a result of the research project 4T12A 032 26. The functional relation between  $E_i$ ,  $P_w$  and  $L$  (logit) was determined. The calculated multiple correlation coefficient  $R = 0.528$  is on the level  $p < 0.05$  significantly different from zero. The model can be used for forecasting the probabilities of strong tremors occurrence.

10.15 - 10.30 a.m.

Xueyi Yu , Bingchao Zhao, Guoliang Zhao, *Key Laboratory of Western Mine Exploitation Hazard Prevention Xi'an University of Science and Technology, China*

#### **DAMAGE CONTROLS MODE OF MINING SUBSIDENCE ABOUT SHAANBEI-JURASSIC COALFIELD IN CHINA**

The development of theories and control technologies on mining subsidence damage is summarized in the article. By analyzing laws and particularities of mining subsidence damage about Shaanbei – Jurassic Coalfield, the article advances that we can apply geology, mine, landform and regional environment and so on to synthetically partition and ascertain control technologies and comprehensive improvement modes about mining damage, then gives the modes of divisional control and improvement on mining

## **SESSION 12**

21st World Mining Congress, 7-11.09.2008, Kraków, Poland

subsidence damage. All of these provide a base of theory and technology for large area mining and zoology environment protection.

10.30 - 11.00 a.m. Coffee break

11.00 - 11.15 a.m.

Wolfgang Bush, *Germany*

### **GERMANY SUBSIDENCE MONITORING USING SAR INTERFEROMETRIC TECHNIQUES**

11.15 - 11.30 a.m.

Eligiusz Jędrzejec, Piotr Kalisz, Andrzej Kowalski, Jerzy Kwiatek

*Central Mining Institute, Poland*

### **NEW SOLUTIONS IN THE FIELD OF SURFACE DEFORMATION PREDICTION AND OBJECT PROTECTION IN MINING AREAS**

The paper contains four solutions developed at the Central Mining Institute (GIG), presented in a synthetic way, comprising: the description of transient surface deformations, computer deformation prediction according to the Knothe-Budryk theory and solutions relating to the assessment of building object reliability, as well as new technologies of pipeline construction and renovation in mining areas. The measurement results of transient deformations (instantaneous, depending on time) at one of hard coal mines were presented. These results constituted among others the basis to propose a new generalised form of the function of time. The developed computer programmes for the prediction of continuous surface deformations were described. New solutions and tool programmes for cooperation with other programmes and external databases were mentioned. Values of safety coefficients of construction reliability of building objects serving the assessment of possibility of mining exploitation conducting were proposed. They can be also used to design building objects in mining areas. The possibilities to use new technologies of construction and renovation of installation networks in mining areas for the protection of sewage systems, water-pipe and gas distribution networks against unfavourable influence of surface deformations were presented.

11.30 - 11.45 a.m.

Agnieszka Malinowska, *AGH University of Science and Technology, Poland*

### **A FUZZY LOGIC-BASED APPROACH TO BUILDING DAMAGE RISK ASSESSMENT CONSIDERING THE SOCIAL AND ECONOMIC VALUE**

Reliable assessing of mining-induced ground movement impact on building structures poses significant problem in Poland. Due to the lack of accurate methods of building damage risk assessment, mines bear high costs of building repair and protection. This problem results from the fact that optimum modeling of potential building damage requires numerous factors which, due to their imprecise and vague characteristics, are difficult to implement into prediction models. With the application of fuzzy logic, dealing with uncertainty and imprecision in decision-making becomes possible. This paper discusses a method that uses a fuzzy inference system to evaluate the degree of structural damage with regard to a building's social and economic value. After summarizing the theoretical framework, the paper provides an example of an application of a fuzzy inference model to structural damage risk assessment in one of the Polish mining areas.

11.45 - 12.00 a.m.

Augustyn Holeksa, Mieczysław Lubryka, Jerzy Majchrzak, Jerzy Śliwiński, „Jas-Mos” coal mine, *Poland*

### **THE IMPACT OF THE EXPLOITATION OF „JAS-MOS” COAL MINE ON THE ROUTE OF A-1 MOTORWAY**



In 1970's and 1980's, within the confines of the search for the optimum passage of the A-1 motorway through the area of the Silesian Province, several options of situation of the passageway crossing heavily urbanised area of the Silesian conurbation were analysed. Each of the proposed options of the motorway route causes environmental, special and social conflicts. The option selected for implementation to some extent interferes with planned mining exploitation. This paper presents the impact of the exploitation of „Jas-Mos” Coal Mine on this motorway.

12.00 - 12.15 p.m. Andrew Jarosz, *Curtin University of Technology-Western Australian School of Mines, Australia*

**DEVELOPMENT OF INSPECTION SYSTEM FOR EVALUATION OF ORE-PASSES AT GRASBERG MINE, PT FREEPORT, INDONESIA.**

The Vertical Opening Inspection System (VOIS), developed at the Western Australian School of Mines, provides inspection and surveying capabilities of vertical openings up to 1000 metres deep. The unique gyro system stabilises the inspection pod and significantly improves the quality of collected data. The system was modified and further developed to allow inspection and survey of the ore passes at Grasberg Mine (PTFI), which are more than 600 m deep. By combining information collected by VOIS with geological and geotechnical data, the mine is able to better manage and plan maintenance and repairs of these ore passes.

12.15 - 12.30 p.m.

Peter Fischer, Axel Preusse, Anton Sroka, *RAG Aktiengesellschaft, Germany*

**EXTRACTION OF HARD COAL CLOSE TO A SHAFT**

Reducing mining costs has become such an important factor in the German coal industry that operators are forced to work only those areas where production costs can be kept low. These areas will normally be located close to the mine shafts because they are easily accessible. Even the shaft pillar is now being considered as part of the winning zone. Before working coal in shaft pillar zones it is essential to assess the impact this will have on the shaft lining. There is a huge difference between sliding and strata-anchored shaft systems. However, if the overburden comprises lightweight soil both types of shaft will have a tendency to protrude from the surrounding ground. The following paper presents the geometrical reasons underlying this reaction and the methods used for predicting and measuring it.

12.30 - 12.45 p.m.

O.O. Glukhov, A.V. Aantsyferov, O.I. Kompanets, *UkrNIMI NAN of Ukraine, Ukraine*

**METHODS AND PRACTICAL RESULTS OF USING GEOMARK GEOINFORMATION SYSTEM IN MINING**

The report gives a description of methods and practical results of using *GeoMark* geoinformation system in mining. It has been developed in the UkrNIMI Institute to solve a wide range of computational problems in the field of mine and land geophysics, geomechanics, and mine-surveying.

12.45 - 1.00 p.m.

Edward Popiołek, Ryszard Hejmanowski, *AGH University of Science and Technology, Poland*

**FORECASTING AND MONITORING OF UNDERGROUND MINERAL SEAM EXPLOITATION INFLUENCE**

This paper presents the most modern view and solutions used in mining areas for the forecasting mining influence on particular buildings and other infrastructure. The main role in our solution plays Knothe theory, forecasting mining influence. The theory has been modified according to current conditions of exploitation fields and implemented in our so called MODEZ software. In the next part of our paper, the most modern instruments and technologies useful in mining areas monitoring are presented. GPS laser scanner and other electronic instruments were described. In detailed form InSAR technology was de-

## **SESSION 12**

21st World Mining Congress, 7-11.09.2008, Kraków, Poland

---

scribed, especially our experience in using it in mining regions of Poland was pointed out. The made so far interferograms for mining area of LGOM allowed the assessment of the possibility to apply satellite radar interferometry in the monitoring mining areas. Underground mining exploitation, in particular in copper mines, is connected with the emission of strong mining tremors. The analysis of the correlation between the shape of isoclines subsidence in interferometric maps and the situation of epicentres indicate that, most tremors cause changes of in the structure of subsidence. In addition, new techniques of spatial data analyses and data distribution based on GIS system were presented. Geographic Information Systems nowadays, play important role in the mining data management and the decision making processes in the mines.

1.00 - 3.00 p.m. Lunch

8.00 p.m.

Banquet at Auditorium Maximum Jagiellonian University, Krupnicza str., Restaurant Hall (Level -1)

**SATELLITE SESSION**10<sup>th</sup> September 2008

Day 4 (Wednesday)

MH A - A Part of Middle Hall in AM

Auditorium Maximum of Jagiellonian University, Krakow

**Session 13****CONTRIBUTION OF STRATA MECHANICS TO MINING  
TECHNOLOGY AND WORK SAFETY****International Symposium organized by the International Bureau  
of Strata Mechanics (IBSM)**

Venue: A Part of Middle Hall in AM (Auditorium Maximum, Krupnicza str, Krakow)

Chairman: Raimo Matikainen, Co- Chairman: Marek Cała  
Secretary: Piotr Małkowski

3.00 - 3.15 p.m. Introduction

3.15 - 3.30 p.m.

T. Szwedzicki, *AusWest Pty Ltd. Perth, Western Australia, Australia***PRECURSORS TO ROCK MASS FAILURE IN UNDERGROUND MINES**

Analysis of documented case studies indicates that each rock mass failure is preceded by a precursory manifestation of rock mass behaviour. Structural damage and progressive failure is manifested by the presence of geotechnical warning signs (indicators and precursors) and can be exacerbated by triggers. Indicators suggest that the rock mass may be prone to damage, whereas geotechnical precursors prove that the rock mass has been damaged and may precede possible failure. The failure process starts with a failure initiation phase, progresses through a propagation phase and ends up in rock mass collapse, rockburst, outburst or inundation. Geotechnical analysis shows that the failures do not happen at random and are not unpredictable in terms of the type of failure and its location. Indicators and precursors have to be interpreted in conjunction with mine design, mining activities and potential triggers. Geotechnical monitoring of the precursory behaviour of the rock mass provides timely warning and allows for implementation of remedial measures.

3.30 – 3.45 p.m.

H. Marcak, *AGH University of Science and Technology, Poland***THE STRUCTURE OF SEISMIC ACCELERATION SIGNALS RECORDED ON  
GROUND SURFACE**

In Poland, there are copper mines in Lower Silesia and coalmines in Upper Silesia where seismic tremors appear. They produce strong ground motion and cause building damage mostly weak, sometimes serious. The damage appears at an epicenter zone and the motion intensity diminishes rapidly with distance. It is difficult to assess the space distribution of seismic signals structure recorded at ground level. The wide band of wave frequency transmitted through rock masses, the influence of focal mechanism and amplification of seismic vibrations due to geological structures causes uncertainty in seismic signals interpretation. The tops of seismic wave amplitudes, commonly used to describe the potential of seismic wave destruction have a particularly high level of uncertainty. It can be shown that the seismic acceleration tops depends on the rupture direction. Also the time of dynamic loading should be considered when estimating the predicted influence of seismic vibrations on buildings. In this paper it is pro-

posed to estimate the parameters of model describing the envelopment of particle ground motion acceleration, due to mining tremors, with the formula  $u = G \cdot \exp(kt)$ . The estimation of parameters  $G$  and  $k$  from a smoothed power spectrum gives an ability to estimate the maximum value of signal envelopment and its length. Ground motion recorded in the coal mine is analyzed and building damage risk is assessed on the basis of some combination of the  $G$  and  $k$  parameters.

3.45- 4.00 p.m.

T.V. Lobanova, V.N. Oparin, A.V. Leontiev, *Institute of Mining, Siberian Branch, Russian Academy of Sciences, Russia*

#### **FEATURES OF ROCK MASS MOVEMENTS UNDER ITS HIGHER GEODYNAMIC ACTIVITY IN TERMS OF THE TASHTAGOL MINE, RUSSIA**

The paper gives consideration on the comprehensive study of the earth surface and rockmass movements in the area of the Tashtagol Mine, Russia. The mine is located in the conditions of higher geodynamic activity, including rock bursts. The authors used methods of traditional and satellite geodesy in their research.

4.00 - 4.15 p.m.

U. Ruppel, U. Langosch, *DMT GmbH, Germany*

#### **STATE OF THE ART. DIMENSIONING OF SHIELD SUPPORT TO OPTIMIZE LONGWALL ROOF CONTROL**

Basic rock-mechanics research has always set itself the target of improving roof control measures at the coal face. The results of this work frequently led to the development of new support equipment. Between 1999 and 2003 a series of underground investigations was carried out as part of a DSK R&D project whose aim was to predict the roof fall frequency and from this to determine the roof control measures required at the longwall face, with a view to submitting recommendations for the operation of the production faces. The interpretation of the coal-face observations yielded the following results: – The geological-geotechnical features and characteristics of the roof strata call for a critical distance between the tip of the shield support canopy and the coal face; only if this critical tip-to-face distance is exceeded can roof falls occur. In order to prevent roof falls the shield supports have to be specifically chosen for each face in such a way that the critical tip-to-face distance is never exceeded under any operating conditions. – If the tip-to-face distance is allowed to exceed the critical threshold, the frequency with which roof falls occurs can be predicted using an empirical equation. From time to time, however, the strata are stressed to such a degree that the technical capabilities of the support system are not sufficient to keep within the critical tip-to-face distance. Roof falls will then be unavoidable. This set of circumstances produces a further set of planning requirements. – Where in the strata is there a suitable layer of rock above the coal seam for optimum roof control? – Will the extension range of the supports still be suitable for this strata layer? The paper provides answers to these questions, presents the results of the recent R&D work and uses practical examples to explain how these state of the art calculation methods can be used.

4.15 - 4.30 p.m.

N. Bulychev, *Tula State University, Russia*

#### **ANALYTICAL DESIGN METHOD FOR VERTICAL SHAFT LINING**

A modern theory of underground structures design has been developed in Russia. The basic principle in the theory is that of joint contact interaction of rock mass and a lining as elements of "rock-support" system subjected to external loads. Main postulate of the theory is that the elastic medium can be taken as the rock mass model. All underground structures design methods of the theory are based on rigorous analytical solutions of the corresponding elasticity theory contact problems. The analytical design method for vertical shaft lining is based on this theory. In generally the reason of shaft lining loading is intact rock mass stress state induced by rock own weight and tectonic forces. Consequently the magnitudes and directions of in situ principal stresses in the rock mass are the important input data. Shaft sinking technology plays an important role in shaft lining loading.

4.30 - 5.00 p.m. Coffee break

5.00 - 5.15 p.m.

N. Fotieva, N. Bulychyev, P. Deev, V. Vladova, *Tula State University, Russia*

**DESIGN OF SUPPORT OF MULTIPLE NON-CIRCULAR WORKINGS IN TECTONIC AREAS**

A new method for the design of support of deep multiple non-circular workings located in tectonic areas, is presented. The method is based on a new analytical solution of the 2D problem of elasticity theory for a linearly deformable medium simulating the rock mass, weakened by an arbitrary number of arbitrarily located openings of different shapes, supported by rings from the other materials simulating the workings support. The action of tectonic forces is simulated by initial stresses in the medium the principal axes of which are inclined under an arbitrary angle with respect to the horizontal and the vertical. The corresponding software has been developed. Examples of the design are given.

5.15 - 5.30 p.m.

S. Prusek, S. Bock, *Central Mining Institute, Poland*

**ASSESSMENT OF ROCK MASS STRESSES AND DEFORMATIONS AROUND MINE WORKINGS BASED ON THREE-DIMENSIONAL NUMERICAL MODELING**

This paper presents an example of application of three-dimensional modelling for the purposes of assessing condition of rock mass around a coal bunker located at a depth of 300 m. The calculations were performed using the Coulomb-Mohr criterion and the method of finite differences. The rock mass modelling was performed by means of the programme FLAC3D developed by HCltasca. The software enables spatial modelling of considerable deformations and destruction of rock mass as well as resolving complex problems stepwise. The applied values of rock mass parameters were gained during underground investigations which included: macroscopic observation, penetrometer tests, introspective tests and laboratory test on samples taken from the bunker's lining and surrounding rocks. Based on that it was possible to assess the rock mass according to the RMR and GSI classifications, as well as to determine values of the key rock-mass parameters used in the numerical methods. Based on an analysis of the spatial stress-and-strain state of the rock mass around the coal bunker as well as taking into consideration the results of the underground tests and observations an assessment of the referred to working's stability has been made.

5.30 - 5.45 p.m.

E. V. Kasparian, *Mining Institute Kola Science Centre RAS, Russia*

**HIERARCHIC-BLOCK MODELS OF ROCK MASS IN MODERN GEOMECHANICS**

The paper describes the properties of hierarchy-block models, their advantages and examples of their application in solution of practical problems concerning the assessment of underground mine workings, open pit benches and slopes stability under the mining conditions on the Kola peninsula. Using hierarchy-block medium models in solution of conventional geomechanical problems substantially reduces the earlier adopted safety coefficients and makes the technical solutions more effective, with the necessary level of safe mining operations being preserved.

5.45 - 6.00 p.m.

A.N. Shashenko, E.A. Sdvizhkova, *National Mining University, Ukraine*

**ANALYSIS OF SOME FAILURE CRITERIONS AND ESTIMATION OF SCALE EFFECT IN ROCKS**

The analytical failure criterion named Parchevsky -Shashenko is proposed in given paper. The comparative analyses shows that Parchevsky -Shashenko criterion describes well enough failure of rocks

**SESSION 13**21st World Mining Congress, 7-11.09.2008, Kraków, Poland

---

and gives more realistic results for strong, brittle rocks than empirical Hoek – Brown failure criterion. Given criterion involves only two mechanical characteristics: uniaxial compressive strength and a factor of brittleness. The scale effect in jointed rocks is accounted for by using statistical strength theory and applying structural factor. It depends on a variation of samples compressive strengths, which characterizes a degree of rock mass heterogeneity on micro-level. To estimate scale effect on macro-level a distance between joints is involved while statistical data processing.

6.00 - 6.15 p.m. Summary

8.00 p.m. Banquet at Auditorium Maximum Jagiellonian University, Krupnicza str.,  
Restaurant Hall (Level -1)

**SATELLITE SESSION****10<sup>th</sup> September 2008****Day 4 (Wednesday)**

PH - Portrait Hall

**Auditorium Maximum of Jagiellonian University,****Krupnicza str**

SESSION SPONSORED BY:

**SESSION 14  
ECONOMICS, MANAGEMENT AND DESIGN  
IN THE MINING INDUSTRY**

Venue: PH - Portrait Hall of Auditorium Maximum

Chairman: John E. Tilton, Co-Chairman: Roman Magda  
Secretary: Patrycja Bąk

9.00 - 9.15 a.m.

G.G. Pivnyak, U.T. Rasumny, A.V. Rukhlov, *National Mining University, Ukraine***ASPECTS OF THE FUEL INDUSTRY DEVELOPMENT IN UKRAINE**

A wide use of systems of decentralized (independent) power engineering should be considered as the modern tendency. One of the priority directions of providing hard fuel power engineering with coal is its quality increase up to economically reasonable level. One of solutions is the effective use of limited financial resource of Ukraine assigned to coal mine construction. The application of combined systems of electric power supply and their working regimes is a very effective solution.

9.15 - 9.30 a.m.

G. G. Pivnyak, P.I. Pilov, *National Mining University, Ukraine***STRATEGY OF COAL INDUSTRY DEVELOPMENT IN UKRAINE**

Positioning of Ukraine on the world power markets can be assessed by means of the following factors. Negative factors are: scantiness of own gas, oil, and nuclear resources; lack of diversification of power product supply sources; the use of overwhelming share of capacities of own water resources; great technogene load as for environment; disappointing technical situation with a part of objects to transport power products. Strategy of coal industry progress in Ukraine is oriented to the increase of volumes of effective and harmless use of coal by power industry taking into consideration investment attractiveness of projects. Realization of the strategy will need to increase production capacities to develop new deposits at the expense of construction of new mines and reconstruction of running ones. [red.]

9.30 - 9.45 a.m.

J. Engel, P. Rybár, *Faculty BERG Technical University Kosice, Slovakia***SUBSTITUTABILITY OF CAPITAL AND SUSTAINABLE DEVELOPMENT IN MINING**

Development and status of mining as well as accessibility of the earth resources is, besides other points, related to the following factors: desired environmental conditions, development and status of

population, maintenance of the sustainable development, advancement and realization of new technologies of all-important countries and coalitions on the world's map. In order to follow its sustainable developmental strategy, the OECD Forum on Future recommended a direction that might effect long-term mutual interaction of technology, economy, society status, and state governments [2]. This recommendation forming development is expected to be mandatory.

9.45 - 10.00 a.m.

V. Bauer, *Faculty BERG Technical University Kosice, Slovakia*

#### **THE RISK EVALUATION IN EXPECTED URANIUM MINING AT SLOVAKIA**

The paper deals with possibilities uranium deposits utilization occurring at the territory of the Slovak Republic. In a brief overview is mentioned the economic potential of existing of exclusive uranium deposits, that are at present time in prospection activities stage. Along with discussed issues there are reviewed qualitative and also quantitative characteristics some today completely prospected, respectively were already in the past before extracted uranium deposits, first of all from rationality and environmentally underground mining with properly selected mining methods point of view. Expected mining activities on the selected underground uranium deposits there are estimated in term of economic because the uranium utilization is very perspective for energy industry and also by electric power production. On the present the energetic uranium deposits utilization constitute very important introduction in the very important field of worldwide contractors activities. The substantial part of contribution refers to both environmental and ethical issues of uranium mining in underground according to existing valid criterium and condition.

10.00 - 10.15 a.m.

K. Doerfler, M. Wurm, *Rio Tinto Minerals Austria, Austria*

#### **TALC MINING IN AUSTRIA: SUSTAINING ACTIVITIES IN THE FACE OF SCARCE RESOURCES AND COMPETING INTERESTS**

Rio Tinto Minerals is the global number one supplier for talc products, which are found in the paint, polymer and paper industries. The subsidiary in Austria operates two mines both based on deposits bearing long term reserves. Mining activities have to care for long term concepts clearly outlined and integrated into the regional policies. For extension projects social and environmental aspects have to be studied carefully in advance to guarantee the sustainability of operations. Heading for excellence: Starting with a precise model of the deposit mine planning is focused on providing maximum value for all stakeholders including environmental and social aspects. Great efforts are made in planning dumps and rehabilitation in the existing open pit mine minimizing the footprint and visibility of all mining activities. By respecting these principles Rio Tinto Minerals has successfully expanded an existing open pit mine for another pit and opened up a new underground operation.

10.15 -10.30 a.m.

Discussion and comments

10.30 - 11.00 a.m.

Coffee break

11.00 - 11.15 a.m.

F. Buse, I.N. Tiuzbaian, N. Dobritoiu, *University of Petrosani, Romania*

#### **THE SIMULATION OF LONGWALL COMPLEX MECHANIZED OPERATING FACE SYSTEM**

For complex mechanized longwall faces, in view of production management in collieries, several kinds of simple process modeling were developed. Existing models don't allow breakings. The proposed model is based on allowing the accidental character of breakings of the equipment's operation. For every face, the average length of the phases is calculated, based on the probability laws and occur-



rence frequency for three types of breakings and considering the equipment's advancing speed. To solve the obtained model, we used a software based on MATLAB language.

11.15 - 11.30 a.m.

N. Tiuzbaian, F. Buse, N. Dobritoiu, *University of Petrosani, Romania*

**THE INFLUENCE OF 'LABOR' PRODUCTION FACTOR UPON WORK QUOTING AND PRODUCTIVITY IN MECHANIZED MINING**

Every mining work of opening or preparing in execution, respectively every mining front, represents a well-established production system, characterized by its own production function. This function determines the quantitative link among the input factors, specific to the individual production system, and the results obtained due to its functioning, results represented by meters of drift or tons of coal. Coal production extracted from a mining depends both on the resources allocated and consumed within the mining and on the natural conditions characteristic to the mining. The production level achieved is a direct result of the mining technology applied as well as of the number of humans that work in the mining. After choosing the mining technology, according to a organizational model selected by the management according to the characteristics of the mining technology chosen, the number of mining workers is going to be established, that is the force of the mining face.

11.30 - 11.45 a.m.

M. Jaszczuk, J. Kania, *Silesian University of Technology, Poland*

**THEORETICAL CONSIDERATION IN ESTABLISHING THE PARAMETERS OF LONGWALL PANEL**

The proposed method is based on a different approach to a longwall face, including the analysis of the costs of the preparatory works stage previous to extraction works. The inclusion of the time factor has led to the derivation of three costs categories: absolutely fixed costs *KBS*, relatively fixed costs *KWS*, variable costs *KZ*. On the grounds of the above mentioned three costs categories an economic model was designed, enabling the designation of daily coal output depending on the reserves of a given longwall panel and its extraction time, for the assumed profit level, or for the assumed balance between the costs of coal production and the incomes from coal sales. The model incorporates the total costs of coal production, including all stages of the production process: preparation works of the longwall panel, longwall moves, extraction works, longwall shut down. The grounds for the model, in accordance with the assumed methodology, were provided by economic modeling used in diagnosing critical functional zones of longwall faces or coalmines. The analysis of the possibilities of obtaining high concentration of extraction under definite mining and geological conditions of a given longwall face requires a model that should make it possible to designate the coal output in view of the technical potential of the longwall system. If it is assumed that the coal output is mainly conditioned by the technical parameters of the shearer loader, the model of the production process in the longwall may be utilized, as it includes: theoretical capacity of the shearer loader, the degree of its utilization under given mining conditions, parameters of the longwall face, actual worktime of mining machinery on a face, cutting sequence. Thus, the analysis entails the technical, organizational and technological aspects. Considering a different course of the production process in the longwall, related to a specific nature of the two basic cutting sequences, the daily coal output from the longwall is function of: theoretical capacity of the shearer loader, available work time of mining machinery on a face, work time availability, operational efficiency index. The theoretical capacity of the shearer loader under given mining conditions is derived in consideration of the technical parameters of the shearer loader and other parameters associated with the natural conditions and a given extraction system. A suggested method for determination of required daily production, which is an indicator of mining production concentration in the aspect of balancing the total cost of coal winning and the revenue from coal selling, can be used for: — determination of minimal daily production, which will ensure effective mining, in conditions of a given longwall (given height, length and panel) and with a use of technical equipment available in the mine, — determination of longwall panel parameters and determination of mining duration for technical equipment available in the mine, selection of technical equipment which will enable effective mining in conditions of a given longwall, for assumed total costs of coal winning.

11.45 - 12.00 a.m.

R. Magda, T. Franik, *AGH University of Science and Technology, Poland*

**PLANNING AND DESIGN OF RATIONAL PARAMETERS OF LONGWALL PANELS IN UNDERGROUND HARD COAL MINES**

Improvement of the management processes in mining companies is the major factor to improve their efficiency. Restructuring actions in the coal mining sector have changed the management structure and organisational systems in the mines and mining companies. Cost and responsibility centres have been identified, the departmental cost accounting, budgeting and controlling systems have been introduced, which opened new perspectives for development of mathematical models and methods to optimise the mine operations. A panel is perceived as a costly element of the spatial structure of mining activities, as it involves both the mining production and development works. A group of neighbouring panels operated by the same equipment unit might be defined as a panel field. Both longwall and exploitation panels are the points where costs are generated. Owing to the application of the departmental cost accounting, costs can be identified and accounted at points where they are generated. This offers new potential for research, particularly in analytical studies, creation of simulation models and calculation procedures supported by state-of-the-art computer techniques and the available numerical modelling packages. This study briefly outlines a certain field within the framework of methodology of designing rational parameters of longwall panels, starting from the analytical method in the deterministic approach, right through to the method supported by stochastic modelling. Application of the Monte Carlo method permits a simulation procedure such that during each iteration the random variables are drawn in such a manner as to fit the probability distribution pattern determined a priori. After a large number of random draws, we get a set of values of the adopted optimisation criterion. Statistical treatment of those values yields the expected value of the investigated criterion and the standard deviation, which is thought to be the best measure of risk.

12.00 - 12.15 p.m.

R. Magda, T. Woźny, S. Głodzik, J. Jasiewicz, *AGH University of Science and Technology, Poland*

**DATA MANAGEMENT FOR THE MINE PRODUCTION PLANNING AND DESIGN**

Key aspects of mining production management involve planning and design, which are very often done by departments of production planning in each mine. This production is very specific because it is inherently accompanied by uncertainty and risk which result from geological, mining, technological and financial- -economical aspects. Alongside the knowledge of mining technologies, those responsible for design of mining operations have to be acquainted with all aspects of underground mining, which sometimes can not be expressed in quantitative terms. Geological and mining conditions of the mine production are unique, therefore, it is necessary to learn them all the time. This imposes on the production planning teams the obligation of systematic learning. In order to facilitate the learning process special tools are needed. The tools must be able to register facts and assist the analysis and the assessment which are necessary to derive the afterthought being the starting point of the feedback in the learning cycle. When monitoring the practical implementation of the planning and design task, we can encounter phenomena which could not be foreseen, difficulties which require adjustments or natural conditions which make change our assumptions. The system of monitoring and data acquisition about the implemented production process becomes of key importance. The system has been developed to be used by the production planning team in correcting the current solution or creating a new one. Thus collected information can be stored in the dedicated database. The paper briefly reviews the concept of a database for the purpose of design and planning of the mining production. This database shall comprise the information on previous mining activities, covering the geological and mining data, technological and financial data. The database is updated accordingly, to account for the progress of mining operations. Of particular importance is the cost accounting at the points where these costs are generated (using the departmental cost accounting, controlling systems and other financial recording and documentation systems). The database might also comprise the fresh and duly processed data to be utilised in the design and planning, for example, it might contain descriptive statistics and probability distributions of parameters used in stochastic models of mining activities (such as: costs, advance of mining equipment, mining advance, shutdown time, repairs, and other random parameters) as well as correlation

and regression functions. The main purpose of the database is to collect information required for stochastic modelling of mining operations taking into account the involved risk and uncertainty.

12.15 - 12.30 p.m. Discussion and comments

1.00 - 3.00 p.m. Lunch

3.00 - 3.15 p.m.

Q. Wang, X. Gu, D. Chu, *College of Resources and Civil Engineering Northeastern University Shenyang Liaoning, China*

#### **A DYNAMIC OPTIMIZATION METHOD FOR DETERMINING CUTOFF GRADES IN UNDERGROUND MINES**

Cutoff grade optimization is an old topic that has been studied by many researchers. However, existing methods cannot find the real optimum solution because they are based on the grade distribution of the entire deposit, while the grade distributions of different sections of the deposit may be much different from that of the entire deposit. A new method is proposed to overcome this shortcoming. This method solves the problem in three steps: 1) Divides the entire deposit into "decision units" based on the mining method and long term mining schedule, 2) the grade distribution of each unit is computed based on the samples falling in the unit, and 3) each unit with its grade distribution is considered as a stage in a Dynamic Programming scheme and the problem is solved by applying the Dynamic Programming algorithm. The new method has been successfully applied to the Chambishi copper mine.

3.15 - 3.30 p.m.

J. Sattarvand, Ch.Niemann-Delius, *RWTH Aachen University, Germany*

#### **PERSPECTIVE OF METAHEURISTIC OPTIMIZATION METHODS IN OPEN PIT PRODUCTION PLANNING**

From mathematical point of view, the problem of open pit production planning is a very large and complex model to solve. Clear definition of ore bodies, normally needs that several millions of blocks to be included in the block model. Uncertain amounts of economic and operational parameters like revenues and costs of mining, estimated grades and geomechanical properties of rocks makes the optimization model almost impossible to be solved totally using traditional mathematic programming methods. In this paper applicability of the metaheuristic optimization methods such as Genetic Algorithm, Simulated Annealing, Ant Colony optimization, Particle Swarm optimization and Tabu search in optimization of open pit mine planning will be discussed. These methods that are widely used in artificial intelligence and other engineering fields have potential of simultaneous solution of very large and complex models, despite their higher calculation time which could be rectify with computer hardware developments in near future.

3.30 - 3.45 p.m.

A. D. Akbari, M. Osanloo, M.A. Shirazi, *Mining Engineering Department Azad University Science and Research Branch, Iran*

#### **ULTIMATE PIT LIMIT (UPL) DETERMINATION THROUGH MINIMIZING RISK COSTS ASSOCIATED WITH PRICE UNCERTAINTY**

Instant development of a pit as same as confining the pit extra development would be practically impossible, if the mine planner didn't have a provision before. Also the bad financial effects of inadequate development will harm the project. Under-development will cause lost benefit while over-development will cause loss. Furthermore estimating the correct fleet of needed machinery, human workforce, and capital investment depend on determining the Ultimate Pit Limit (UPL). The deliberations in this study showed that the most important factor among impressive factors in the UPL determination is the metal price. Further deliberations showed the metal price time series are non-stationary time series and their behaviors are difficult to predict, whereas the entire UPL determination algorithms haven't noted to the factor of metal price uncertainty until now. Hence this study tried to formulate the problem through a risk assessment model. The resultant formulae of this study altogether forma UPL determination model

based on a risk costs minimizing strategy. This heuristic methodology includes three main types of formulae for the lower and upper boundaries and also for in the middle circumstances which their combination is capable of finding the UPL in different situations.

3.45 - 4.00 p.m.

A. Shahinkar, K. Shahriar, A. Asadi, A.D. Akbari, *Mining Engineering Department Azad University Science and Research Branch, Iran*

#### **FEASIBILITY STUDY OF OIL MINING - A FUZZY AHP DECISION MAKING APPROACH**

Today, unheard increasing oil price up to 115 \$/bbl as well as using new technologies, concurrent with decreasing the World's light oil resources, made enhanced heavy oil recovery very economically attractive. Recovering the remained heavy oil at oil fields after primary production (oil gushing under its own pressure or being pumped) involves two stages, called *Secondary production* including technologies such as water flooding and gas injection by enhanced recovery factor about 15–33% and *Tertiary production* including technologies such as CO<sub>2</sub> and steam injection or polymer flooding by enhanced recovery factor about 35–38% respectively. This means that about 65% of oil can not be recovered even after applying the mentioned technologies. Mining oil is the fourth order of oil recovery technology which may result in the economic production of up to 90% of the oil remaining in the unrecoverable reservoirs. Last evaluations in the literatures returns in two decades, so in this paper a comprehensive feasibility study has done by using a new Fuzzy AHP approach. Finally a sensitivity analysis of the criteria and sub criteria is done to observe the effects on the final recovery method with changes in the status of the individual factors.

4.00 - 4.15 p.m.

H. Owladeghaffari, K. Shahriar, Gh. R. Saeedi, *Mining Engineering Department of Shahid Bahonar University, Iran*

#### **ASSESSMENT OF EFFECTIVE PARAMETERS ON DILUTION USING APPROXIMATE REASONING METHODS IN LONGWALL MINING METHOD, IRAN COAL MINES**

Approximately more than 90% of all coal production in Iranian underground mines is derived directly longwall mining method. Out – of – seam dilution (namely 20–30%) is one of the essential problems in these mines. Therefore the dilution can impose the additional cost of mining and milling. As a result, recognition of the effective parameters on the dilution has a remarkable role in industry. In this way, this paper has analyzed the influence of 13 parameters (attributed variables) versus the decision attribute (dilution value), so that using two approximate reasoning methods, namely Rough Set Theory (RST) and Self Organizing Neuro-Fuzzy Inference System (SONFIS) the best rules on our collected data sets has been extracted. The other benefit of later methods is to predict new unknown cases. So, the reduced sets (reducts) by RST have been obtained. Therefore the emerged results by utilizing mentioned methods shows that the high sensitive variables are "thickness of layer, length of stope, rate of advance, number of miners, type of advancing".

4.15 - 4.30 p.m. Discussion and comments

4.30 - 5.00 p.m. Coffee break

5.00 - 5.15 p.m.

R. Sayadi, M. A. Hosseini, V. Bozorgi, *Tarbiat Modarres Universit, Iran*

#### **PRICE INSTABILITY AND TERMS OF TRADE FOR MINERAL COMMODITIES IN THE LAST TWO DECADES**

Variation and instability of goods prices and TOT as indices for reviewing their behavior through time are used to evaluate gains from exchange of commodities for countries. In recent two decades, the world prices of mineral commodities have experienced dramatic variation and fluctuation. In this re-

search, the behavior of mineral commodities prices, with the help of indices of price trends, instability of prices and TOT, is investigated. The results show that the greatest degree of instability and fluctuation has related to minerals commodities prices and their TOT, relative to those of industrials products, have improved more than twofold. Although the shares of many minerals commodities, specially oil and nickel, in world trade have increased, but the greatest fluctuation and instability also relate to these commodities.

5.15 - 5.30 p.m.

B. Soliński, I. Soliński, *AGH University of Science and Technology, Poland*

**ECONOMICAL APPRAISAL OF THE ENERGETIC APPLICATION OF HARD COAL IN CO-COMBUSTION PROCESS WITH BIOMASS IN SYSTEM POWER PLANTS**

The profitability analysis of co-firing biomass with coal is an important issue from the view point of possible increase and the development of biomass utilization for electricity production. The paper deals with the economic appraisal of co-firing biomass with coal. Utilization of biomass in large power plants is analyzed with special emphasis on the impact of additional cost of biomass feedstock on final cost of electricity and on the benefit resulting from reduced payments for emission as well as from selling green certificates in large system power stations.

5.30 - 5.45 p.m.

M. Sierpińska, A. Kustra, *AGH University of Science and Technology, Poland*

**BONUS SYSTEMS IN MINING INDUSTRY, CURRENT SITUATION AND FUTURE DEVELOPMENTS**

The paper covers an analysis of bonus systems in mining industry and offers a proposal of changes in this matter. Bonuses represent from 7 to 10% of the total remuneration of all mining industry workers. In Authors' opinion these bonuses should represent at least 15–20% share in the structure of the remuneration. There is a need for adjusting basis for granting bonuses and implement indicators used in controlling. The most crucial parameter for granting bonuses should be meeting budgeted costs. In addition this basis should control for assignments aimed at improving quality, increase in productivity of assets involved directly in mining and financial results. Authors advocate consistency to be maintained in evaluation and bonus systems at all management levels in mining industry.

5.45 - 6.00 p.m.

A. Kustra, *AGH University of Science and Technology, Poland*

**COST CALCULATION IN THE MINING ACTIVITY TREATED AS A PROJECT - STRATEGIC AND OPERATIONAL APPROACH**

The subject of the report is costs calculation in the mining factory in order to manage its effectiveness. Two approach ways were presented: strategic and operational, depending on needs and analysis level. Strategic approach identifies cost recognition and its evidence on each stage of the mining-geological project connected with the deposit exploration and estimation, building mining factory, exploitation and mine liquidation. Operational approach presents project approach with a parcel exploitation being part of the hard coal stratum in the underground mine.

6.00 - 6.15 p.m.

A. Dyczko, M. Kopacz, *Mineral and Energy Economy Research Institute of Polish Academy of Sciences, Poland*

**DILUTION INFLUENCE ON VALUE OF MINING INVESTMENT PROJECTS AND SELECTED PRODUCTION FIGURES BY A COPPER MINE EXAMPLE**

Mine production activity is connected with resources exploitation of specified quality parameters. However, it is often necessary to increase the output of production by adding extra rocks, containing some amount of metals having industrial utilization. Determining and measuring the influence of dilution on the

miners' economics results, also on technical level, is an important and interesting issue. One of the basic factors, deciding in majority on the effectiveness of mining and utilization of mining products is **dilution**, often considered as quality losses [4]. It is understood and indisputable that crude ore exploited by the company is usually characterized by worse qualities than those indicated by deposit's ore sample. Such phenomenon usually takes place in case of metal deposits and is referred to as **dilution**. Commonly, three kinds of dilution are distinguished: — dilution deriving from mixing natural ore resources with rocks, — dilution deriving from mixing gangues with ore resources, — dilution deriving from loss of rich but little fractions of useful metals. Dilution regarded in such way, considered only on a mine's level, can be defined as traditional approach; as such, it has already been precisely recognized and described. The problem here is how to transform the knowledge about amount and type of dilution given at separate stages of exploitation process into information useful for assessment, both at the technical and economical level of the entire technological process? How to provide the collected information with new quality, necessary in the process of creating and controlling production effectiveness of a big mining corporation [5, 6]? Nowadays, it is almost a truism to say that precise knowledge of the actual content of copper and other metals in a vein of processed material is a very important part of the production process. Contemporarily, it is known that such knowledge constitutes a basis for measuring production effectiveness, and combined with cost-related information allows for profit assessment. In such approach, the dilution referred to quality losses of reserves, rises to one of the most important issue describing the structure of the process in the technological continuum from mines to processing and, further on, to copper concentrate refining. In the literature, there are many relations to the problem connected with reserves utilization. Besides the general characteristic of dilution, the authors provide classification and present various formulas allowing for its quantification, measurement and calculation in different geological and mining conditions. On the other hand, there is no clear answer what is the dilution influence on both the mining effectiveness and the value of investment projects classified to the same category because of specific environment condition and development. In the presented paper, besides verification of dilution influence on investment projects' value, variability of key parameters were assessed, including: revenues, production costs, production of copper concentrate, production of copper (Cu), production of silver (Ag). Possessing series of empiric data determining production results from one of the leading global producers of copper in the years 2005–2007, it was decided to quantify the influence of dilution on example of experimental copper project X. The project joined a concept of development of an already existing mine and new elements proposed by the authors to execute research purposes. The key assumption was verified by constructing a modified Discounted Cash Flow-model, including elements of income statement and mathematic modelling. The indicator used for measuring the economic value of the project was NPV (Net Present Value).

6.15 - 6.30 p.m.

P. Bał, *AGH University of Science and Technology, Poland*

#### **SECURITIZATION AS A METHOD OF FINANCING COAL MINING INDUSTRY**

Internal capital, which finances the development of the already existing company generally comes from the owner's capital share and the retained profits. The company which values its market position spends all or some of its profits on investments, thus limiting payments of the dividend. Another means of enlarging the internal capital is gaining it from the former or new owners. The possibilities of capital accumulation are varied and they depend on the organizational and legal structure of the entity. Internal capital in a joint stock company is enhanced through shares issue. The development of the company can also be done by external capital, namely long-term bank credits, loans given by financial entities and bonds. Bank credits are the main source of gaining external capital on the Polish market. Companies can make use of credit which are offered by competing banks. Another source of external capital is issuing and sale of the company bonds. Bonds are a long-term instrument for financing large companies. They also give access to capital other than bank credit. Economic development, changes of the capital market and investment knowledge of Polish entrepreneurs create conditions for new forms of capital gaining, such as securitization. It is a financial technique which makes capital gaining possible for those entities, which have had no possibilities of obtaining financial means on securities markets. Both investment and flow capital can be obtained that way. The process is based on the transfer of assets which were separated from the company balance into securities. These securities become then an object of flow. Asset securitization is an alternative form of financing economical activity as compared with bank credits or issuing securities. In Poland, securitization is still a novelty on the capital

## **SESSION 14**

21st World Mining Congress, 7-11.09.2008, Kraków, Poland

---

market. In Western Europe, these instruments are most often purchased by investors. Securitization is then another step towards new methods of financing.

6.30 - 6.45 Closing Session

8.00 p.m.

Banquet at Auditorium Maximum Jagiellonian University, Krupnicza str., Restaurant Hall (Level -1)

**POSTER SESSION**

**11:30 a.m – 12:30 p.m,  
11 September 2008 Auditorium Maximum  
of the Jagiellonian University (Krupnicza str.)**

Z. Adamec, *GEMEC – UNION, Ltd. Company, Jivka, Czech Republic*

A. Grmela, *VSB – Technical University of OSTRAVA, IGI, Ostrava–Poruba, Czech Republic, ATH – University of Bielsko-Biala, IEEP, Bielsko-Biala, Poland*

K. Novotny, *GEMEC – UNION, Ltd. Company, Jivka, Czech Republic*

V. Slivka, *VSB – Technical University of OSTRAVA, IGI, Ostrava–Poruba, Czech Republic*

**THE REVITALIZATION OF UNDERGROUND AND SURFACE ENVIRONMENT  
OF THE LIQUIDATIONS MINES – ELIMINATION OF RISKS FROM MINE  
WATERS AND GASES DISCHARGE ON SURFACE**

Establishment of an underground environment of a mine should in any case prevent geomechanical and environmental risks. Condition of use of basic mixture of any type is a necessity to carefully evaluate the underground hydrogeological situation and hydrological bonds between a mine and surface water-courses or other bonds between mine workings and the environment. Complex research of these relations and practical application of these bonds were realized in the Czech Republic on the mine J. Sverma in Zacler (systematical filling of available mine workings by self-solidifying flood mixture on a basis of ash material from the lowest levels up to the surface). From the beginning of the systematical mine liquidation (1994) to the final phases (2006) the hydrogeological situation of mine workings and surface was monitored, as well as discharges and migrations of mine gases. The results are compared with other procedures and methods of liquidation of underground mines (simple flooding of mine workings, liquidation of only opening workings /shafts, adits/ etc.). Results of observations of mine mash of a coal seam in the depth of 70m below the surface are also presented and especially from the viewpoint of the risks during underground operation (intention to leave a tourist route) and influence on the environment in the places of bassets seams onto the surface.

H. Aghajani, *Shahrood University of Technology, Shahrood, Iran*

A. Moradzadeh, *Shahrood University of Technology, Shahrood, Iran*

**SALT DOMES' DEPTH ESTIMATION USING NORMALIZED FULL GRADIENT  
OF GRAVITY DATA**

The normalized full gradient (NFG) technique applies to interpret potential field data in order to detect any hydrocarbon prospect. This method was generally used for the downward continuation of potential data for detecting of any possible reservoir. In this study, several models such as, spheres and vertical cylinders with different radius and depths have been used to produce synthetic data to calculate NFG values at the first stage. The NFG approach has then applied on two sets of real field gravity data to determine the location and depth of the Mors salt dome, Denmark and Humble salt dome in USA. The obtained results on synthetic gravity data indicate the maximum of NFG values coincide with the locations of synthetic spheres. The application of this method on real data illustrates the NFG method is able enough to locate salt domes and their depth of burial precisely but its results highly depend to the number of terms of Fourier series and length of profile.

S. Anaç, N. Tamzok, *Turkish Coal Enterprises, Ankara*

**STRUCTURAL TRANSFORMATION IN THE TURKISH MINING INDUSTRY**

The extensive transformation in the general economy policy of Turkey since the 1980s has shown some critical reflections on the mining industry of Turkey approximately in the same period. Mining legislation and the institutional structure of the industry have undergone some comprehensive changes. The public sector-dominant structure of the mining sector of Turkey has been transformed into a private capital-



dominant one especially as from the 1990s. In this study, the transformation process in the mining industry of Turkey has been presented and some outcomes of the process have been examined.

V. Arad, R. Moraru, G. Băbuț, T. Goldan, *University of Petroșani, Petroșani, Romania*

**THE IMPACT OF UNDERGROUND MINING ON THE SURFACE GROUND IN JIU VALLEY**

Besides the conservation and closing activities, an important issue to achieve is the environmental rehabilitation of the mining perimeters, also assuring the continuity and viability of the mining activity in the Jiu Valley. The restructuring process of the mining industry has important implications in the coal exploitation and tailing from coal preparation in Jiu Valley. In the mining industry, as a consequence of repeated changes suffered by the basic rocks the roof and floor of deposits are weakened from a geo-technical point of view. Underground mining has negative influence to the surface land. There are producing many landfalls, land subsidence and land breakages affecting the buildings in this area. Protection of the surface land and of underground mining works is provided by means of supporting pillars. Underground coal pillars support a total surface of about 2450 ha, and these include coal reserves amounting about 460 millions tones.

Wojciech Batko, Andrzej Mikulski, Witold Cioch, *batko/mikulski/cioch@agh.edu.pl AGH University of Science and Technolgy, Department of Mechanics and Vibroacoustics*

**NEW METHOD OF DIAGNOSTIC OF STEEL REINFORCEMENT IN MINING SHAFT**

This article presents a new testing method allowing for expeditious recognizing of the condition of elements of the entire shaft and selecting the most worn-out elements, which can be subsequently subject to more detailed examination. For the purpose of evaluating the technical state in a short time and at the same time securing the reliable results, new examination procedures were formed, helpful in detection and localization of damages in the elements of mining-shaft reinforcement. The essence of this method is examining the dynamic properties of a structure with the application of pulse test that involves exciting vibrations in the structure and measuring excitation response. The procedures relate to modal experiments, supplementing contained in those experiments procedures of signal processing with algorithms of wavelet expansion. This solution extended the possibilities of pulse-test applications and generated new carriers of information on the state of diagnosed elements. Starting point is the assumption that in the moment of damage occurring in the structure, basic dynamic parameters (e.g. damping) change. Mathematical tools hinge on simultaneous signal processing in time and frequency domains. It involves signal analysis with the application of Fourier transformate of wavelet function. The analysis was implemented in designing and constructing of portable microprocessor-based measurement system dedicated to non-stationary signal analysis. Diagnostical device constructed with the application of most recent electronic technologies is fitted with control keys and LCD display. It was programmed with consideration of diagnosing guiding-rails for mining-shaft lifts, using pulse test methods Timeconsuming operations of signal processing were executed in reprogrammable FPGA systems. Verification of the developed method of examining shaft reinforcement was conducted on one of the mining-shafts at Copper Mining & Metallurgy Complex „Polska Miedz” in Polkowice. Results of conducted examinations of over 80 guiding rails of different wear-state are discussed in the article.

Nadil Berbic, Abduselam Adilović *Univerzitet u Tuzli, Tuzla, Bosna i Hercegovina*  
Amir Brigic, *RMU “Banovici” d.d. Banovici, Banovici, Bosna i Hercegovina*

**THE ESTIMATION OF IMPERILING OF THE NEAREST SURROUNDINGS OF STRIP MINING BY THE NOISE OF TRUCK TRANSPORTATION**

Ibrahim Lapandić, *RMU “Banovici” d.d. Banovici, Banovici, Bosna i Hercegovina*  
High stage of noise accrued with excavation assembly process represents the problem. That problem in some cases more or less disrupts quality of living in the area which immediately surrounds excavations. In other words in some areas is not rare case for mineral raw materials exploitation to be done near

urban areas with big number of population which more endanger that area according to ecological aspect. This project is only concerned with noise problem in that area and its basic characteristics. In order of solving this noise problem it is necessary to commit noise transmission and its parameters of basic assembly machines and process. In this labour is analysed noise impact on area the truck transport produces on excavations. Some equivalent measures were done on the ground and based on its basic clues they were given for the spoilt methodology of the realistic estimate and danger state that surrounds excavation.

Jian-hong Chen, Li-bing Yang, Yun-cai cheng, Hai-yang Yang, *The School of Resources and Safety Engineering of Central South University, Changsha, Hunan province, China*

### **SIMULATING AND OPTIMIZING OF ORE TRANSPORTATION SYSTEM IN STRIP MINE**

The ore transportation system of strip mines is a representative discrete-event system, so the data concerning facilities and resource are collected and extracted to obtain their statistical probability by Expertfit; Based on Flexsim, Then 3D model is developed, incarnating the relationship among transport, resource and facilities, thereby, which vividly simulates, anal sizes and optimizes the producing-transport system of strip mines. It puts forward two dispatching method, Grade-threshold dispatching and Passive-Dispatched Truck, and sets three indexes in orthogonal designs, including truck utilization ratio, producing-facility utilization ratio and standard deviation of Aluminum to Silicon ratio(DAS). Those optimization schemes, referring to site-transportation network and dispatching plan, can minimize the cost and optimize material composition by analyzing simulation model; It gains the optimization decision-making of temporary reserves in washing bauxite site, number of trucks and ways of dispatching, meanwhile, forecasts and analyzes latency influence factors and sensitivity. The simulation results validate the rationality and correctness of simulation system.

V. Driban, *UkrNIMI, Donetsk, Ukraine*

### **ON THE NEW APPROACH TO THE PROBLEM OF MAINTENANCE MINE WORKINGS**

Based on experimental data analysis and obtained by the author novel solutions on distribution of stress fields and deformations in rock mass enclosing mine workings it is shown that in the course of deformation rock mass undergoes successively discrete series of states that correspond to a definite ratio of physical-mechanical properties of rock mass and rock pressure level. It is determine that when an outline of mine working is deformed by 12-18%, the latter bifurcates (looses its stability) that corresponds to bifurcational solutions for plasticity equations.

M. C. Fu, *School of Land Sciences and Technology, China University of Geosciences, Beijing, China*

J. H. Zhou, *Tangshan Branch of China Coal Research Institute, Tangshan, Hebei, China*

Q. J. Chen, *School of Surveying and Land Information Engineering; Henan Polytechnic University, Jiaozuo, Henan, China*

### **LANDSCAPE PATTERN EVOLVEMENT IN MINING AREA: A CASE OF LIYUAN TOWN IN CHINA**

Landscape pattern in mining area is both the result of long-term action of multi driving forces and the base of regional coordination and development. This paper takes Liyuan Town, where Jinggezhuang locates, in Tangshan as an example and analyzes land use changes in the year 1997 and 2003 using GIS. The results showed that in mining area in urban-rural fringe of plain area, the number and the fragmentation of the patches increased and the patch density as the whole was in a rising trend. And the patch number of each type of landscape distributed unevenly. The landscape pattern characteristics and evolvment in Liyuan Town indicates that under the double functions of mining development and urbanization, it is necessary adequately to obey the evolvment regularity of special landscape in region

to promote the evolvement of landscape destruction, restoration, reconstruction and function, in order to realize the regional coordination development.

Z. Z. Fuginski, S. P. Reshetnyak, *“SPb-Giproshaht”, St.-Petersburg, Russia*

**BASIC CHALLENGES IN THE MODERN THEORY AND PRACTICE OF IRON ORE OPEN PIT MINES DESIGN**

Russia owns vast experience in low-grade iron ore open pit mining (25–30% magnetic iron content). Many iron pits have currently 300 m depth to be 600–800 m deep in future. Fore these pits there have been developed: combined transportation including ore and waste; advanced blasting in near-wall areas; new wall design having slope angles of up to 60°.

Z. Z. Fuginski, *SPb Giproshakht, Askar Enikiev, Business Development and Planning, SPb Giproshakht St. Petersburg, Russia*

**INCREASED DEMAND FOR COAL – GROWING MARKET FOR DEPOSIT EVALUATIONS AND MINE DESIGN SERVICES IN RUSSIA**

The coal reserves in the territory of Russia are more scattered than those of oil and natural gas, and at the same time the main coal reserves are concentrated in several large coal basins including Tunguskij having reserves of 2,345 billion tonnes, Lenskij (1647 Bt.), Kuznetskij (725 Bt) and Kansk- Achinskij (601 Bt). The biggest coal mining operations are also concentrated in Central and East Siberia and in the Far East. The Russian share of the explored world coal reserves is 12% and estimated resources are equal to 30% of the total global coal or to 6.8 trillion tonnes, 70% of which is hard coal. The collapse of the USSR resulted in a significant part of its coal base transferring to Ukraine and Kazakhstan. In 1990 the share of coal production in the Russian Federation equaled 55.7%, that in Ukraine 23.7% and Kazakhstan 18.8%.

B. Füsser, *Karl Hamacher GmbH, Germany*

**PERFORMANCE INCREASE OF LONGWALL SYSTEMS – PRESERVATION OF RESOURCES**

In the last ten years the performance of longwall systems has been increased significantly. This was made possible by an acceleration of shearer speed as well as extended panel length and/or width. But all of these factors have an enormous impact on the pressure supply systems at the face. For this it will be crucial to point out the actual effects and to show economically reasonable solutions.

S. Zh. Galiyev, A. A. Boyandinova, A. C. Bektureev, E. A. Shabelnikov & Zh. A.

Boyandinova, *Mining Institute after D. A. Kunayev NC IMR, Kazakhstan*

K. K. Zhusupov, *Joint-stock company “Kostanay minerals”, Kazakhstan*

**CONCEPT OF CORPORATE MANAGEMENT OF GEOTECHNOLOGICAL COMPLEXES ON SURFACE MINES**

Creation of new state-of-the-art productions in the branch and transition to higher technical and technological level are possible only on the basis of active motivation of scientific organization of production ensuring the sustainable development of mining city-forming companies in the mineral resource market. These issues in the mining field should be considered by the science called “mining systemology” studying the regularities of development and methods of determination of geosystems’ parameters, management of its functioning and use in view of consequences of mining for society and nature. The geosystem – its new definition – is a complex of natural and artificial objects with the properties of the system, created and used in the purpose of mining. It covers concepts of production, natural and technical, territorial, social and economic and other objects of mining when its study and management is done by means of detection, analysis, generalization and evaluation of the systems’ structure, determination of its properties...

M. Golestanifar, *Department of mine engineering, Science and Research branch, Islamic Azad University, Tehran, Iran.*

S. Behzadnia, *Department of marine science & technology, Islamic Azad University, North Tehran branch, Tehran, Iran.*

A. Aghajani Bazzazi, *Department of Mining Engineering, Islamic Azad University, Savadkooh Branch, Iran*

**INSITU BIOTREATMENT OF COAL SPOIL HEAP DRAINAGE WITH PERMEABLE REACTIVE BARRIERS (PRBS)**

Coal spoil heap drainage, characterized by low pH and high concentrations of sulfate and heavy metals, is an important and widespread environmental problem related to the coal mining industry. Permeable reactive barriers (PRBs) can degrade or immobilize contaminants in-situ without any need to bring them up to the surface. As the contaminated groundwater moves passively through the treatment wall, the contaminants are removed by physical, chemical and/or biological processes, including precipitation, sorption, oxidation/reduction, fixation, or degradation. The reactions that take place in such systems depend on a number of parameters such as pH, oxidation/reduction potential, concentrations, and kinetics. Therefore, successful application of this technology requires a sufficient characterization of contaminants, groundwater flow regime and subsurface geology. In this paper a comprehensive review of effective parameters for design PRBs with a proposal prepare to Central Alborz Coal mine is considered.

J. E. Pérez González, Y. Martínez Lobaina, *Empresa de Servicios Minero Geológico-EXPLOMAT, Havana City, Cuba*

**NATURAL RECULTIVATION (RESTORATION) OF QUARRIES AND OPEN PIT MINING**

Natural Recultivation (Restoration) is one of the methods ensuring better technical and economic results. Classification of the main processes of the Natural Recultivation (Restoration) are as follows: • Natural Recultivation (Restoration). • Technical Mining Recultivation. • Biological Recultivation. The paper discusses determination of the main conditions, allowing to proceed with the Recultivation (Restoration). Moreover, the paper presents the methodology of calculation of the main mining works, allowing to carry out the closing of mines so that Natural Recultivation can be performed.

I. L. Gumenik, V. V. Panchenko, *National Mining University, Dnipropetrovsk, Ukraine*

**DEVELOPING METHODOLOGY OF DESIGNING AND PLANNING MINING OPERATIONS UNDER OPEN-CAST MINING OPERATIONS OF IRON-ORE DEPOSITS**

Basic conceptions of creating and developing new methodology of designing and planning open-cast mining operations have been offered. System number of new methodology constituents from the point of view of these conceptions has been substantiated. The results of development and approbation of its separate constituents are given.

Zijad Ibrisimovic, *Prof. University of Tuzla*, Kemal Gutic, *Dr. Sc University of Tuzla*  
Amir Barakovic, *Prof. University of Tuzla*, Sejid Osmanovic, *Mr Sc Mine "Breza"*

**POSSIBILITIES FOR REVITALIZATION OF THE MAGNESITE MINE "KONJUH" KLADANJ, BOSNIA AND HERZEGOVINA**

In this work there are presented possibilities for revitalisation of the Magnesite mine "Konjuh" in Kladanj, on topic mineral reserves, exploitation technology, investments and ecology. This work, also, presents development program of mine, from starting production minerals to building new plants for manufacturing final products by caustic and sinter magnesite.

Juraj B. Ďurove, *Technical University of Košice, Slovakia*; Imrich Dúdor, *SMZ, joint-stock company, Jelsava, Slovakia*;

**MINING ACTIVITIES OF MAGNESITE EXTRACTION IN JELSAVA MINE**

Magnesite works in Jelsava is the greatest mining and manufacturing magnesite plant in the Slovak Republic (Slovakia). The magnesite deposit in Jelsava is largest deposit of this non-metallic raw material in Slovakia. The extraction and processing of this magnesite has been carried out longer than one hundred years. During the time of its existence the company went through different kinds of transformation process. Nowadays, it is a property of joint-stock company. The volume of magnesite products from Slovakia covers the fourth place in the world scale, and it is supposition that it will hold in the future, too.

Klishin V. I., Kokoulin D. I., Repin A. A., Alekseyev S. E., Druzhinin M. M., *Institute of Mining, Siberian Branch, Russian Academy of Sciences, Novosibirsk, Russia*

**DRILLING RIGS FOR MAKING ANCHORS AND BLAST HOLES AT COAL MINES**

A brief review of drilling rigs for making technological and anchor holes is reported. The demand for development of new drilling rigs, being efficient for hard rock interlayers ( $\sigma_{ж} \leq 140$  MPa), is substantiated. Specifications are given for drilling rigs and pneumatic punches. Data on bench and prototype field tests are supplied.

N. P. Kosarev & V. A. Gordeev, *Ural State Mining University, Ekaterinburg, Russia*

**TRAINING OF MINING ENGINEERS IN THE URALS**

Training mining engineers in the Urals is being carried out at 14 colleges and 4 universities. The oldest higher school in the Urals – Ural State Mining University – trains specialists in 58 specialities, including 16 mining ones. More than 12 thousand students are being taught at the university. The basis of teaching is the task of development and realization of the single and continuous vertical structure of education – from a pre-school level till a postgraduate one. This integrated vertical structure provides for a high quality of professional training and guaranteed employment of graduates.

G.V. Kyryk, *Concern "Ukrrosmetall", Ukraine*

**USAGE OF MEMBRANE GAS SEPARATING STATIONS FOR FIRE PREVENTION AND EXTIN-GUISHING IN MINE WORKINGS**

The results of design and use of membrane gas separating stations for fire prevention and fire extinguishing in the coal mines of Ukraine are cited. The characteristic of different types of gas separating stations and its working parameters are given.

O. Music, *Faculty of Mining, Geology and Civil Engineering, Univerzity of Tuzla, Bosnia and Herzegovina*

S. Zekan, *Faculty of Mining, Geology and Civil Engineering, Univerzity of Tuzla, Bosnia and Herzegovina*

M. Memic, *Tuzla Mining Institute, Tuzla, Bosnia and Herzegovina*

**ROOM DESIGN BY FUNCTION OF MINE-GEOLOGICAL DEPOSIT CONDITIONS**

One of the base parameters at mining engineering is determination of room shape which is in function of mining-geological conditions of massif. It is given new approach of determination of basic room shape elements (width, length and height). Room and pillar width calculation, is done theoretical and presented primer in case brown coal mine « Djurdjevik » in Djurdjevik, Bosnia and Herzegovina.

Oleksandr F. Nehreshchenjuk, A. V. Martovitskij, Petro N. Klanovets, SC «Pavlogradvugilla», Pavlograd, Ukraine, Viktor V. Lapko, National Mining University, Dnipropetrovsk, Ukraine

**MODERN CONDITION AND PERSPECTIVE DIRECTIONS OF DEVELOPMENT OF COAL MINES OF THE WESTERN DONBASS**

Modern technical and economic position of the State Company (SC) "Pavlogradugol" is presented. The basic content of «Program of perspective development of SC "Pavlogradugol" till 2015 with an intrusion of new progressive technologies and the equipment» is opened. The coal deposit of the Western Donbass is located on the left slope of Dneprovsko-Donetsk cavity, in basin of the river Samara, the left inflow of the Dniپر river, and occupies about 12 thousand sq. km (length 250 km, width of 40–50 km). The deposit covers the Petropavlovsky, Pavlogradsky, Novomoskovsky, Tsarichansky areas of the Dnepropetrovsk area and Lozovsky area of the Kharkov area ....

Parate N. S. Professor and Head, & Jim Pae Lem, *MPhil Student*, Department of Mining Engineering, PNG University of Technology, LAE, Morobe Province 411, Papua New Guinea. E-mail: nparate@mining.unitech.ac.pg ;jlem@mining.unitech.ac.pg

**DISPOSAL OF MINING WASTES AND MILL TAILINGS IN PAPUA NEW GUINEA**

Papua New Guinea being a major producer of gold and copper, has three world class and two medium-scale gold and copper mines most of which have life of more than ten (10) years. These mines though contribute two-thirds of country's GDP, produce a lot of mine and mill wastes that are not properly controlled. Papua New Guinea mines have a record of poor wastes management since the mine and mill wastes do not have permanent impoundments. The mill wastes are discharged directly to the river systems or ocean whereas the mine waste rocks that are dumped at temporary sites on the surface also finds their way to the water systems through surface run-off. The paper discusses the present status of environmental impacts of different waste disposal practices in Papua New Guinea

Henryk Pawełczyk, *Stowarzyszenie Inżynierów i Techników Górnictwa*  
**METHOD OF DESIGNING AND EXECUTING DOG HEADINGS ALONG WITH ASSESSMENT OF DRILLING EFFECTIVENESS – WS COEFFICIENT**

The objective of the paper is to prove the argument that it is possible to provide mathematical specification and assessment of progress in the driven or designed dog heading in view of: – natural hazards, – operational difficulties, – organisational factors, – other phenomena, often of fate origin. The argument was verified under the following conditions: – in the mined rock mass there are typical geological and mining situations of similar nature, irrespective of the mine and of the drilling place, – drilling the headings was executed with AM75 gallery shearers and, to a lesser degree, with AM65 and AM85, – the measures and method of output haulage and delivery of materials were of supplementary nature. The methodology of the research was based on: – collecting the necessary data within a proper document focused on the argument, – monitoring and analysing the collected data in monthly cycles, – determining the set of data, the so-called "RcZ" set, which consists of 10 selected parameters which are related to the objective and to the argument, – preparing classification of parameters of the "RcZ" set: the "weights" and, in consequence, defining the empirical formula to enable calculation of the Ws coefficient, – determining the impact range of the Ws coefficient and building of a chart with progress assessment zones for practical application. The prepared base constituted the basis for the comprehensive analysis and drawing conclusions in the subject matter. According to the author, the method will allow increased effectiveness and safety and more effective management of preparatory works.

A. Rafiee, *PhD Student, Zanjan University, Iran*, M. Vinches, *Lecturer, Alès School of Mines, France*, C. Bohatier, *Professor, Laboratory LMGC, University of Montpellier 2, France*

**APPLICATION OF THE NSCD METHOD TO THE STABILITY ANALYSIS OF JOINTED ROCK MASSES**

This paper introduces the application of a new method for the mechanical modelling of a fractured rock mass. The Non-Smooth Contact Dynamics (NSCD) method is a numerical method for computing the dynamical motion of collections of bodies submitted to the unilateral constraints of mutual non-interpenetrability, taking into account an interaction law in the case of contact and the velocity jumps which may arise from collisions. The essential non-smoothness of the problem is tackled without resorting to any regularizing approximation such as artificial repulsion or artificial viscosity. The method is used here for the simulation of a jointed rock mass model, generated using the statistical analysis of the discontinuity orientation data derived from the field measurements in a stone quarry located in the southwest of France. The 3D jointed rock mass model is generated in the Auto CAD® environment by the code developed for this purpose. In addition, stability analyses are performed in three and two dimensions using the LMGC90 code in which the NSCD method is incorporated. This calculation code is able to perform simulations for the collection of discrete bodies in two dimensions for both rigid and deformable elements, and in three dimensions for rigid elements. The application of the LMGC90 code and the algorithm used for generating the jointed rock mass model are discussed in detail for the case study.

Sima Seyed Salmasi, Mohammad Hosein Basiri, *Tarbiyat Modarres University*

**RISK EVALUATION IN THE MINING INDUSTRY**

Mining is a long term, risky business and needs advanced engineering practices as well as considerable amounts of capital. This paper highlight the aspects, namely that of sourcing the capital required both to locate and put a mining operating into being. Many of the issues, such as country risk assessments, are perceptual rather than factual, but they do have a major bearing on where money flows will be directed. Overall capital will find its way to those projects that offer the best combination of potential capital return and security. In this study the major factors that will come into play before a positive investment decision is made to commit capital to a mining or exploration projects.

A. N. Shashenko, E. A. Sdvizhkova, *National Mining University, Dnipropetrovsk, Ukraine*

**ANALYSIS OF SOME FAILURE CRITERIONS AND ESTIMATION OF SCALE EFFECT IN ROCKS**

The analytical failure criterion named Parchevsky -Shashenko is proposed in given paper. The comparative analyses shows that Parchevsky -Shashenko criterion describes well enough failure of rocks and gives more realistic results for strong, brittle rocks then empirical Hoek – Brown failure criterion. Given criterion involves only two mechanical characteristics: uniaxial compressive strength and a factor of brittleness. The scale effect in jointed rocks is accounted by using statistical strength theory and applying structural factor. It depends on a variation of samples compressive strengths, which characterizes a degree of rock mass heterogeneity on micro-level. To estimate scale effect on macro-level a distance between joints is involved while statistical data processing.

Gurdeep Singh, *Centre of Mining Environment/ Department of Environmental Science & Engineering, Indian School of Mines University, Dhanbad, INDIA*, Arun Kumar Shukla, *DGM (Env.), NMDC Ltd., Masab Tank, Castle Hills, Hyderabad INDIA*

**ENVIRONMENTAL ISSUES WITH BEST PRACTICE EXAMPLES OF RESPONSIBLE MINING IN INDIA**

Mining, despite the very substantial benefits it bestow on society, stir strong emotions. Mining operations damage the environment and ecology to an unacceptable degree, unless carefully planned and

controlled. The rapid, unchecked and sometimes biased activities result in air, water and noise pollution, land degradation, health hazards, loss of forest wealth and agricultural land, drying of wells, rehabilitation problems leading to large scale environmental deterioration. The negative impact of mining on health, land, water, air, plants and animals, and other aspects of society can be reduced by careful planning and implementation of mining activities. It is essential to strike a balance between mineral developments on the one hand and the restoration of the environment on the other.

R. Šišić, A. Bašić, E. Delić, Z. Karadžin, *University of Tuzla, Faculty of Mining, Geology and Civil Engineering, Tuzla, Bosnia and Herzegovina*

### **EXPANSION CHAMBERS AS STRUCTURES FOR PROTECTION AGAINST DYNAMIC COMPONENT OF EXPLOSION WAVES IN UNDERGROUND MINES**

Preventative measures against thermal or chemical action of explosion are integrated into mining practice and legislative. However, dynamic explosion action, i.e. action of high overpressures created due to explosion are insufficiently researched. There is no clear view of changes in air-dynamic potentials, i.e. intensity of shock wave during explosion movement down an mining gallery, nor influence of geometry and configuration of mine rooms and ventilation network on shock wave properties. A great number of influencing factors, specificity of mine ambient, insufficient number of experiments conducted in real (mine) conditions, are the main causes for possessing only rough assumptions on dynamic action of explosion waves. There is a specific strategy defined for industry of liquid and gas hydrocarbons (oil and gas) against dynamic action of explosions. Due to specificity of conditions in underground mines, this strategy can not be simply copied, but gives general guidelines and tools required for defining possible prevention and protection systems, of both humans and equipment, against relating dynamic actions ...

G. I. Solovyov, O. K. Moroz, J. A. Liashok, *National Technical University, Donetsk, Ukraine*  
S. S. Griebionkin, *National University of Management, Donetsk, Ukraine*  
S. D. Kierkiez, A. M. Galchenko, *«Lisichanskugol» State Holding Company, Lisichansk, Ukraine*

### **COMBINED METHODS OF STABILITY PROVIDING IN PREPARATORY MINE-WORKINGS OF DEEP MINES IN DONETSK REGION**

Here proposed the new conception of preparatory mine-workings stability providing in deep mines on account of new combined method of arched timbering hard-longitude reinforcement with cast band and the layer roofing crutching

M. Stjepanović, *Engineering Academy (JINA), Belgrade, Serbia*  
Mile Bugarin, *Mining and Metallurgy Institute Bor, Serbia*  
Dimča Jenić, *B. Mining – Smelting Basin Bor, Serbia*  
Milenko Ljubojev, *Mining and Metallurgy Institute Bor, Serbia*

### **CURRENT PROBLEMS AND OUTLOOKS FOR THE UNDERGROUND MINING OF DEPOSITS IN SERBIA**

In many countries of the world as well as in Serbia, mining is under the process of changing and all of them, as regards their reality and potential, take into account the issue of finding a solution for restructuring and adaptation to the newly established conditions. This report gives the evaluation of condition and outlooks for underground mining development, especially involving deep deposits of mineral resources in Serbia, with the emphasis on directions and priorities of scientific research for the purposes of production in transformation from current CONVENTIONAL MINE MODEL at higher level of MECHANIZED MINE MODEL and level of so called "INTELLIGENT MINE", followed by larger development and implementation of new alternative technologies for mining.



V. D. Sydorenko, I. S. Paranko, *Kryvyi Rih technical university, Kryvyi Rih, Ukraine*

**THE INTEGRATED SOLUTION OF ECOLOGICAL, ECONOMIC AND SOCIAL PROBLEMS OF MINING REGIONS AS A GUARANTEE OF THEIR SUSTAINABLE DEVELOPMENT (BY THE EXAMPLE OF KRYVYI RIH IRON-ORE BASIN)**

For many years a one-sided approach in studying and producing mineral raw materials in Ukraine mining complexes has been formed. For example, the main minerals of Kryvyi Rih iron ore basin are ferruginous quartzites; the main mineral of Donbass is coal; the main minerals of Nikopol basin are manganese ores; the main mineral of the Western Ukrainian sulphur region is sulphur and so on. In addition, from 30 to 70% of mineral mass which is mined from the mineral reserves and contains commercial concentrations of ore-bearing elements and non-metal minerals are stored in dumps and tailing ponds thus threatening the environment.

M. A. Trevits, L. Yuan, A. C Smith, E. D. Thimons, G. V. Goodman, *National Institute for Occupational Safety and Health, Pittsburgh Research Laboratory, Pittsburgh, PA, USA*

**THE STATUS OF MINE FIRE RESEARCH IN THE UNITED STATES**

During the time period from 1990-2007, 1601 reportable fires occurred in the U.S. mining industry (an average of 89 fires per year). The leading causes of U.S. mine fires were flame cutting and welding operations, frictional heating and ignitions, electrical shorts, mobile equipment malfunctions, and spontaneous combustion. The fact that mine fires continue to occur with an alarming regularity reinforces the importance of recognizing and eliminating the potential hazards and the overall need for improved fire control and suppression technology to ensure the best possible outcome during a mine fire. The National Institute for Occupational Safety and Health (NIOSH) is conducting an evolving comprehensive program of research that is addressing mine fire prevention, detection, management and suppression. This paper presents a summary of recent research accomplishments and provides an overview of the next phase of the NIOSH mine fire research program.

Academician K. N. Trubetskoy, Yu.P. Galchenko, G.V. Sabyanin, *Russia, Institute of Problems of Complex Development of Bowels of the Earth of the Russian Academy of Sciences (IPCDB RAS)*

**CONCEPT OF SUBSURFACE DEVELOPMENT OF BOWELS OF THE EARTH ON THE BASIS OF "FRAMEWORK" GEOTECHNOLOGY**

Technological pressure on natural ecological systems during extraction of Earth subsurface resources leads to irreversible changes of those systems. This impact quickly becomes global in nature. Internal dynamic of mining industry influence on the environment is defined today by the increasing contradiction between the constant market demand of mining exploration cost reduction, and ecological necessity to preserve the environment in its entirety. Evolutionary development of geo-technologies historically did not take into account the importance of ecological factors. Consequently, the increase in productivity and profitability of applied mining technologies is accompanied by rapidly increasing destruction of nature and environmental contamination. Implementation of Frame Geo-Technology for underground subsurface resources exploration can provide us with unique opportunity to overcome this contradiction. Modern views on the advances in the area of the excess stress relaxation in continuous ...

L. Tsotsorkov, 'Assarel – Medet' JSCo, L. Totev, *University of Mining and Geology 'St. Ivan Rilski', Al. Chobanov, 'Assarel – Medet' JSCo*

**THE PERSONNEL PROBLEM OF THE MINING COMPANIES IN BULGARIA – STATE AND PERSPECTIVE. ASSAREL-MEDET'S EXPERIENCE IN INCREASING THE EMPLOYEES' QUALIFICATION AND MOTIVATION**

During the years of the transition in Bulgaria, after 1989, the issue with the personnel provision of the mining company was seriously intensified. On one hand this was caused by the liquidation of uranium mining, fading functions of the major coal mining and ore mining companies and their subsequent liqui-

dition and on the other hand by the opportunity for the young educated specialists to leave the country and look for their realization abroad – mostly in Western European countries, the USA, Canada. The demographic decrease also had its input to the problem aggravating.

L. Tsotsorkov, 'Assarel – Medet' JSCo, N. Lulov, 'Assarel – Medet' JSCo  
**SUSTAINABLE DEVELOPMENT BETWEEN ENVIRONMENT AND MINING  
INDUSTRY. ASPECTS OF THE ENVIRONMENTAL RESPONSIBILITY OF  
ASSAREL-MEDET JSC, BULGARIA**

Since the dawn of their development mining and processing industries have created a continuously sharpening conflict between the use of natural resources and environment preservation and protection. Even unconsciously in the beginning, by mining ores and minerals, men exposed waste products to secondary autogenous treatment causing local environmental problems. However, they were small and did not have a significant impact upon natural systems and they allowed them to self-adjust and maintain them. On the other hand, in the remote past there were no unbiased prerequisites for unsustainable usage of natural resources taking into consideration the small volume of mining activities and primitive equipment and the priorities of the ancient miners and societies used to differ significantly from the contemporary ones.

S. B. Tulub, A. N. Shashenko, A. B. Ivanov, V. I. Korol, *National Mining University,  
Dnipropetrovsk, Ukraine*

**DEVELOPMENT OF ACOUSTIC METHOD FOR ROCK MASS STRESSED  
STATE MONITORING IN THE COURSE OF UNDERGROUND MINING**

Rock pressure in the critical areas of mine stope and development workings under complicated mining and geological conditions often leads to catastrophic sudden outbursts of coal, rock and gas. Existing methods and means aimed at providing the underground workings stability and workers' safety do not give the desired effect. The most general approach to a problem of ensuring the underground workings stability under conditions of burst risk and geological irregularities is estimation of the potential energy accumulated in the rock mass with complicated structure. Use of acoustic fluctuations as the informative parameters is the most applicable for solving the problem of prognosis of burst risk zones in the rock mass. The prognosis is based on the fact of interaction of these vibrations energy with potential energy enclosed in the area of their extension. In the National Mining University, Ukraine, the principally new method of the zone active probing with use the artificial signal created by noise from operating machines is developed. The results, obtained by this method, do not depend of the natural rock mass noise. They are integral estimation of the studied area condition and provide control of mechanical tensions occurred in it. The obtained results made possible to suggest the method for use in the automated control system of a heading machine and corresponding recommendations were elaborated.

Valentin Tzatzov, Ellatzite Med Ltd., [v.tzatzov@ellatzite-med.com](mailto:v.tzatzov@ellatzite-med.com)

**REVIEW OF THE TUNNEL CONSTRUCTION SERVICING THE WORK OF  
“ELLATZITE” OPEN-PIT MINE**

“Ellatzite” open-pit mine is situated approximately 80 km east of Sofia, on the northern side of the Balkan Mountains, close to the town of Etropole. The construction of the ore-dressing complex started in 1976. The ore deposit is managed by open-pit mining. The mining technology is classical – drill-and-blast works conducted with modern mining equipment through the drilling and blasting of 15-meter steps with cartridge and emulsion blasting materials produced by Geotechmin Ltd.

Song Zi-an, Wang Zhi-jie, *Longkou Mineral group Industry Construction Co. Long-  
kou Shandong Province, China*

**THE COMPARISON OF MECHANICAL ELEMENTS OF ROCK WITH  
DIFFERENT CALCULATION METHODS**

The mechanics computing by the application of the outer collapse angle  $\alpha$ , Which has basic relationship of the mechanical parameters ( $\alpha$ ,  $c$ ,  $\sigma$ ), they have characteristics of clear and intuitive. The outer col-

lapse angle formula can calculate various mechanical elements of rock underground. The mechanical elements of rock underground of different rock character calculated by the Kastner formula and the outer collapse angle formula, we can see the commonalities and differences of the calculating formula.

\*\*\*

### **Articles published in proceedings of Session no 1: NEW TECHNOLOGIES IN MINING**

Gennadiy Gayko, Vladimir Kasianov, *Donbass State Technical University, Alchevsk, Ukraine*

#### **THE CONCEPT OF MINE-POWER-STATION INVOLVING THE UNDERGROUND BURNING OF COAL STRATA**

The problem of increasing the productivity of coal thermo-chemical processing within the area of its bedding is considered. The new mining method of flame bit run of thin coal layers is offered. Parameters heat-technical system "a rocky massif a pipe header – electrical generating units" are investigated. Was given the analysis of socio-economic perspectives of a new technology.

B.B. Danilov, *Institute of Mining, Siberian Branch, Russian Academy of Sciences, Russia*

#### **SUBSTANTIATION AND SELECTION OF BASIC TECHNOLOGICAL PRINCIPLES FOR THE EVOLVEMENT OF A NEW PROCEDURE OF THE CONTROLLED HORIZONTAL DRILLING**

The paper presents the classification of methods for piping in a soil mass, considering physics of holing, stabilization of holes and force impact on a work tool. Analyzing the principal piping methods points to the paths of technological advancement. The author has formulated the classification features for the promising methods of piping in a soil mass. The advantages of piping jointly with the force impact on a tool and partial removal of rocks are theoretically reasoned and experimentally proved. It is proposed to remove rock from a hole by using the compressed air stream. Having determined the key parameters of an air conveying system, the author has shown feasibility of designing a new drilling machine for the described piping method.

B.N. Smolyanitsky & A.A. Lipin, *Institute of Mining, Siberian Branch, Russian Academy of Sciences, Novosibirsk, Russia*

#### **DOWNHOLE AIR-HAMMER DRILLING MACHINES WITH CENTRAL DRILL FINES CONVEYING**

The status and development trends are discussed for the downhole air-hammer drilling machines with central drill cutting conveying (counter-current circulation) in the opencast and underground mining, and in drilling the exploration holes to obtain representative samples. The paper presents specifications for new-generation machines with a feeding-rarefying air distribution system, which allows the machine to operate with a core tool for rock breaking. The circulation and downhole cleaning by the return energy carrier is described, that ensures collecting the drill cuttings all over the drilled hole and conveying them into the main drill cuttings pass-way for the analysis of samples and referencing them to the particular intervals of the hole.

P. Czaja, J. Hydzik, *AGH – University of Science and Technology, Faculty of Mining and Geoengineering, Krakow, Poland*

#### **NEW GENERATION CONCRETE IN UNDERGROUND CONSTRUCTIONS**

A continuous increase of demand for mineral resources requires the opening up of new deposits, which results in the necessity to sink new shafts and dip roads from the surface. The application of new materials, especially of HPC and SCC, to build new underground constructions in difficult mining and geological conditions may significantly influence the changes in the construction of lining, increase the

durability and lower the construction costs. The possibility analysis to make such concrete structures in difficult shaft conditions was carried out in laboratory tests and in numerical computations.

Vladimir I. Klishin, Sergey V. Klishin, *Mining Institute, Novosibirsk, Russia*

**ESTIMATION OF THE DEFLECTED MODE IN EDGE ZONES OF A COAL PILLARS**

Equipment, which has not analogues are developed and made for realization of the method of directional hydraulic fracturing in the conditions of underground mining. Algorithms and original software are developed, allowing to numerically investigating the most important characteristics of the deflected mode of a roof, a powered support and a coal pillar, and also their interaction. Solutions of boundary-value problems on deformation and destruction of massif and pillar both in case of continuous rocks, and in case of the rock weakened by directional cracks of a hydro breakage are received.

A.G. Temchenko, V.S. Morkun, V.D. Sidorenko, *Kryvyi Rih Technical University, Kryvyi Rih, Ukraine*

**MINING EFFICIENCY INCREASE BY USING ENERGY SAVING TECHNOLOGIES**

Ukraine's technological strength greatly depends on iron ore industry state. The most important factor providing metallurgical raw materials competitiveness is the quality of products. Iron content in iron ore extracted from Kryvyi Rih basin is 5% less and silica content is 10% higher than those of main world producers. Thus, as to raw material grade, iron ore products of Ukraine's mining enterprises cannot compete with other exporters such as Brazil, Sweden, Republic of South Africa and others. In order to solve different significant economy problems of raw mineral production and processing, especially Kryvbas iron ores, the research group of Kryvyi Rih Technical University, National Mining University and production staff of "Ukrudprom" association studied, developed and brought out (1970–2006) the complex of resource and energy saving technologies for raw material production and processing, technical means of their monitoring with control system and ore mining production optimization. Besides, theoretical grounds have been considered, a complex of technical and program means, process and technical – organizational decisions have been made and realized on an industrial scale. Using operating capacity of mining enterprises these factors enable to increase iron ore extraction into a concentrate, to extend its output, to cut down operating costs, to reduce production costs and, thereby, to guarantee product competitiveness in the world market. In 2006 this project was awarded with Ukraine's State Prize in the field of science and engineering.

Andrzej Papiński, *Institute of Industrial Organic Chemistry, Warsaw, Poland*

Andrzej Maranda, *Institute of Industrial Organic Chemistry, Warsaw, Military University of Technology, Warsaw, Poland*

**INVESTIGATION OF ENERGETIC CHARACTERISTICS OF EMULSION EXPLOSIVES CONTAINING COOLING SALTS**

Energetic characteristics of newly developed emulsion explosives are investigated. Since several years emulsion explosives become to be one of the basic shot agents that are employed in Polish mining industry. However, up to nowadays emulsion explosives are applied in rock blasting only. Simultaneously, for a couple of years extensive research works are carried up to develop the optional kinds of explosives that can be used in shot operations done in presence of coal dust and methane. In the present paper the results of explosive characteristic of emulsion explosive containing cooling salts are presented. The explosives containing sodium and ammonium chlorides are considered. Experimental registrations of detonation velocity confirm preserving of satisfactory performance of obtained explosive mixtures. In all investigated samples the detonation velocity was at about of 4500 m/s, by salts content of about of 10+15%. To explore the explosive properties of investigated class of emulsion explosives the thermodynamical analysis of the influence of added salts upon energetic characteristics of explosion products is performed. The evaluation system based of minimization of the thermodynamic potential of considered reactive mixture is used. The developed algorithm enables of effective identification of the presence of components in condensed phase, i.e. in liquid or solid state, in explosion products. Temperature of explosion products, explosion energy as well as the amount of gaseous products, per unit mass of explosive, are estimated. The ranges of cooling salts concentrations up to of 40%, by mass, in

the explosive mixture are investigated. Obtained results indicate the reciprocal relations that occur between the process of lowering of the temperature of explosion products and reduction of explosive performance (explosion energy and the amount of gaseous products of explosion). The presented results enable to examine the dependence between lowering of temperature explosion products that is necessary to assure the safe use of explosives in possible presence or combustible substances like methane and coal dust, in the shot neighbourhood and, with loosing of the explosive performance that occurs by addition of cooling salts. Additionally, auxiliary characteristics, oxygen balance and enthalpy of formation of investigated explosive mixtures are presented.

Shobeir Arshadnejad, *Mining Engineering Department, Islamic Azad University, Mahalat branch, Iran*, Hossein Hassani, *Faculty of Mining, Metallurgical and Petroleum Engineering, Amirkabir University, Tehran, Iran*, Dariush Kave Ahangaran, *Mining Engineering Department, Islamic Azad University, South of Tehran branch, Iran*

**EMPIRICAL MODELS FOR PREDICTION OF FLY ROCK IN DEMOLISHING OF BRICK CHIMNEYS**

One of the important requirements of big cities are demolishing of old buildings and making some new buildings. Demolition is a mixture of mining engineering and civil engineering techniques. Fly rock and determination of safe distance is a main problem in demolition technique that is considered in this paper. A physical modelling was used for this research. The model was a brick chimney and was used three types of blasting mat in around of body chimney. The blasting mat covered the drilling area. Usual specific charge for a brick wall with 35 cm (thickness) is  $3.5 \text{ kg/m}^3$  but specific charge was  $2.45 \text{ kg/m}^3$  by 32 mm drill holes, in the research. About 70 samples were used for regression analysis. Three experimental models are presented by three parameters. These parameters are mass of particles, throw distance and maximum bearing tensile of blasting mats. For other value of blasting mat strength can be interpolated in the final diagram.

\*\*\*

**Articles published in proceedings of Session no 2:  
METHODS OF UNDERGROUND AND OPEN PIT MINING**

S. Duzy, *Department of Geomechanics, Underground Construction and Land Surface Protection, Faculty of Mining and Geology, Silesian University of Technology, Gliwice, Poland*

**THE EVALUATION OF HEADING STABILITY MAINTENANCE CONDITIONS IN COLLIERIES UNDERTAKING INFORMATION UNRELIABILITY**

Conducting mining exploit causes the need to make many accessible and preparatory headings, to design which much data is used. The analysis of the heading support construction reliability and safety can be conducted based on deterministic and probabilistic methods. In the used probabilistic method as the heading support reliability gauge, the probability of heading stability loss is accepted. On the basis of heading behaviour and stability loss probability relation analysis, a classification, that specifies 6 classes of heading stability maintenance conditions, was compiled. The boundaries of each class have been defined with the assumption, that the heading behaviour, defined for each class, occurs with a 0.95 probability. The conducted comparative analysis have shown great result similarities between theoretical considerations and observations in headings in collieries.

Thomas Drnek, Thomas Frömmer, *RHI AG, Austria*.

**DEVELOPMENTS, CHALLENGES AND TRENDS IN AUSTRIAN MAGNESITE MINING**

Magnesite has been mined in Austria since the middle of the 19th century. Magnesite is the main source for magnesia, which is mainly used in the refractories industry. The company RHI, or its forming companies have been mining magnesite in Austria since 1881. It started with the mine in Veitsch. In 1903

the mine in Breitenau followed, and then the Radenthein mine in 1908. Operations in Hochfilzen began in 1957. Today the existing mines are expanded further to cover the growing demand for magnesia from the world's steel industry. This article describes the company RHI, the magnesia refractories market situation and, in detail, the new developments at the mines in Breitenau, Radenthein and Hochfilzen.

S.B. Stazhevsky\*, A.A. Kramadzhyan\*, B.N. Smolyanitsky\*, M.Ya. Kritsky\*\*

\* *Institute of Mining, Siberian Branch, Russian Academy of Sciences, Russia*

\*\* *Siberian State University of Communications, Novosibirsk, Russia*

**DOWEL BARS AND ROCKBOLTS, TECHNOLOGIES AND MACHINES FOR THEIR INSTALLATION**

The paper proves the efficiency of dowel bars and rockbolts with retainers made of granular materials, to be used for reinforcement of slopes in soil masses. The interaction between the installations and geomedium has been considered. The authors give recommendations on application of the technologies and impulse-forming machines for installation of the discussed structures, and present their test data.

Volodymyr I. Bondarenko, Petro I. Pilov, *National Mining University, Dnipropetrovsk, Ukraine*

**QUALITY CHANGING IN TECHNOLOGY FOR BROWN COAL, PEAT AND SLIMES BRIQUETTING**

The new bracketing technology of secondary fuel and brown coal is developed at National Mining University, Dnipropetrovsk, Ukraine. It is based on the adhesion and chemical processes, proceeding in viscously plastic systems, formed by thin disperse particles of coal and occurrence their knitting properties. It is possible to make composite fuel which components is the mix of coal and anthracite slimes, brown coal, and various waste products containing organic substances.

A. Khodadadi, *Amirkabir University of Technology, Iran*

**Investigation of gas migration in Khangiran wells**

Gas leakage through cemented wellbore annuli is a major problem in many oil wells in the world. Enormous amounts of money are spent on squeeze cementing these affected wells often without affecting a permanent solution. It is important to differentiate between "Gas Migration" and "Gas Leakage". "Gas Migration" occurs by incompatible contraction – expansion mechanism during cement setting, whereas "Gas Leakage" occurs by some secondary mechanisms after cement setting. The objective of this study was to clarify that which of the above mentioned phenomena has occurred in the Khangiran gas field. Nine main factors that could be effective in "Gas migration" or "Gas Leakage" have been compared. Consequently, be clarified that "Gas Leakage" has occurred in Khangiran gas field because of some factors such as use Bentonite and supplement water in lead and tail cements, no cement return, poor mud and mud cake removal, mechanical stresses and produced, induced, thermal micro annulus.

\*\*\*

**Articles published in proceedings of Session no 3:  
UNDERGROUND MINE ENVIRONMENT**

Strumiński\*, B. Madeja-Strumińska\*\*, \* *Kghm Cuprum, Wrocław*, \*\* *Wrocław University Of Technology, Faculty Of Geoengineering, Mining And Geology, Poland*

**PREDICTING BASIC AEROLOGICAL HAZARDS IN UNDERGROUND MINES**

In coal and copper mines, different aerological hazards, especially methane, fire, climate, toxic gases etc., may appear. The previous methods of their evaluation concern in general „the past”, and exceptionally „the present”, what results from the current measuring technique, which give the aerological parameters, in general, after some shorter or longer period of time. It means that we know „the past” of the hazard conditions, or exceptionally, when we use special gauges, the hazard conditions at the

moment of measurements. If the results show that the specific regulations or standards are exceeded, we have the failure dangerous for the miners safety. Such failures usually require stopping the production and starting the rescue action, what is vital with regard of work safety and mining economy. From the point of mining practice, in order to increase the work safety and coal or copper production effectiveness, the knowledge about „the future” of specific mine hazards is especially important. Since it may facilitate the selection of effective technical and organizational measures, in order to avoid the aerological failures which are the cause of mine accidents. Taking this into consideration some methods of hazards prediction, which are caused by toxic and explosive gases and temperature, were presented.

Zbigniew Isakow, Zdzisław Krzystanek, Stanisław Trenczek, Piotr Wojtas  
*Centrum Elektryfikacji i Automatykacji Górnictwa, Katowice, Poland*  
*Research and Development Centre for Electrical Engineering and Automation in Mining EMAG, Katowice, Poland*

### **INTEGRATED SYSTEM FOR ENVIRONMENTAL HAZARDS MONITORING IN POLISH MINING**

In the paper the Authors briefly described the main environmental hazards occurring in the Polish mining have been characterized regarding their potential level determined according to regulations in force. There has been emphasized that a real state of hazards may differ from the potential level. Therefore a continuous monitoring of the occurring hazards is extremely important. The impact of research development and of dangerous and tragic events occurred and caused by hazards on expending knowledge about these phenomena and improvement in regulations has been discussed. It results in necessity to use the most safe machines and devices, mining technologies, suitable control and measuring equipment for short-term measurements and continuous monitoring of hazards and to organize properly mining works. Intensity of respective hazards in the last sixty years of the Polish hard coal mining has been presented. In the beginning i.e. in the years 1945-65 a fire hazard was prevailing, then in the years 1965-85 a methane hazard played a crucial role and next in the years 1985-95 a rock-bump hazard was important. Since 1995 the associated hazards are prevailing, so it means these are the hazards which interact and intensify in this manner a level of danger. A history of development of measuring instruments, devices and systems designed for monitoring and control of gas and rock-bump hazards in the Polish mining has been presented in the paper. They were used for control and monitoring of the prevailing hazard and were characterized by high dynamic of development of them. Next there have been presented in the paper the up-to-date Polish implementations of the systems designed for a complex monitoring and control of gas and rock-bump hazards. The monitoring systems, unique all over the world and awarded many times, have been shown. There has been emphasized at the end of the paper, that the increasing level of hazards requires intense research to be continued on solutions allowing increase in hazard to be compensated by wider range of control/monitoring and accuracy of measurements.

Z. Burtan, A. Zorychta, D. Chlebowski, *AGH University of Science and Technology - Krakow, Poland*

### **TRENDS IN THE DEVELOPMENT OF PREVENTIVE MEASURES AGAINST NATURAL HAZARDS IN POLISH COLLIERIES**

The distinctive feature of the mining sector in Poland is that underground mining operations are threatened by nearly all natural hazards whilst the scale and intensity of their occurrence seems to be growing each year. That applies mostly to hazards associated with methane emissions, self-ignition of coal seams, seismic activity of the rock strata and adverse climatic conditions. The paper summarizes the mining and geological conditions characteristic of coal deposits in Poland as well as technical factors that might further intensify those natural risks. Of particular interest are: depth of the deposit, structure and physico-mechanical properties of coal seams and the surrounding strata, geological disturbances, previous mining activities, the employed mining method, concentration of coal production and sub-level mining. Natural hazards encountered in Polish collieries are summarized and outlined: methane emissions, coal dust bursts, fire, climatic impacts, caving-in, rock bursts, gas outbursts and water hazard. The analysis of the mining conditions and the hazard conditions clearly reveals that these hazards might be intensified in the future, particularly the methane emissions, fires, climatic impacts and rock bursts.

Preventive measures are outlined, involving the monitoring, forecasting and control measures. Thus defined preventive actions include: – development of existing and new measuring and recording systems for the monitoring of natural hazards: fires, methane emissions, rock bursts – design of new preventive measures and the best harmonised procedures in case of concurrent hazards Improvement of existing methods and development of the new monitoring and preventive techniques will permit safety-oriented mining activities in the future.

Zdzisław Iwulski, *AGH - University of Science and Technology, Krakow, Poland*

**MATHEMATICAL MODEL FOR HIGH-ENERGY TREMOR PREDICTION**

In this paper mathematical model to describe phenomena connected with underground exploitation of copper ore was shown. In many cases huge experimental equipment (infrastructure) necessary to get complete information about phenomena is inaccessible. In cases of incomplete information, empirical model should be used. In fact, mechanistic models and empirical models are radically different. Models used here are hybrid of them. Especially, it's possible to use theoretical information to recommend category (class) of mathematical functions, which could be used to fit empirical data. That means, that number of model parameters and their values are estimating on the basis of empirical data. The scope is using seismological observations for evaluation of bumps risk on the basis of interpreted sequence of seismological data composed of vectors containing following information: time, localization and energy of seismological events. Author's objective was to build mathematical model, which could let estimate development of high-energy tremors that come. Not any model is genuine absolutely. Follow that, at sufficient number of data, statistic tests can reject model, which is completely satisfactory for our purposes. On retreat, tests could not discover serious deviations from accepted assumption, if these tests are insensitive on type of occurring deviations. The best way is application most sensitive statistic methods with simultaneously preparation that we would use model worst adjusted if they are rudiments for that. It is obvious, that diagnostic verification must put model in some threat, i.e. must be sensitive for deviations that could occur. Not any system of diagnostic verification is complete, because leaving out of some properties of unexpected data could always happen. However, if carried diagnostic verification has been applied intelligently for selected model, based on proper big numbers of data and if it has not showed serious deviations, it is possible to use this model with great confidence.

Mirosław Bagiński, *Central Mines Rescue Station S.A., Poland*

**PROTECTING WORKERS IN MINING COMPANIES WITH RESPIRATORY PROTECTIVE EMERGENCY ESCAPE DEVICES – QUALITY AND EFFICIENCY**

The present paper gives an overview on the issues related to the protection of miners with the respiratory protective emergency escape devices in consideration of valid regulations, necessity and methods of use. The topics discussed herein refer to apparently important issues related to the training systems and equipment, specifications and necessity to use the equipment, which – due to the close links with the safety in underground mining workings – should be considered and organised, and make it possible to outline the scope of activities for all parties, namely the employers, mining supervision bodies and the legislator. Due to the specific conditions

L. Tsotsorkov, Al. Chobanov, *'Assarel – Medet' JSCo, Bulgaria*

**THE COMPANY POLICY FOR PROVIDING OF HEALTH AND SAFETY LABOR CONDITIONS**

Our contemporary society is setting higher challenges towards the development of the technologies for the mining and processing of ores and towards providing of such labor conditions, in order to have no risk for the life and health of the employees, or this risk to be within the minimum levels. For Republic of Bulgaria the providing of health and safety labor conditions is a requirement of the Constitution, Law for health and safety labor conditions, dated 1996 and the special Regulation, transposing Directive 92/104 of the EEU for the minimum requirements for safety and health in the mining of minerals /mines/.



Jerzy Rydlewski, *AGH University of Science and Technology, Krakow, Poland*

### **SELECTION OF THE SAFEST MINE BASED ON MEASUREMENT OF WORK SAFETY RANKS**

The paper presents the way of choosing the safest hard coal mine from the period 2004-2006. The analyzed mines were those, where no fatal or severe accidents happened in the researched period. Additionally, values of a new, preventive index, index of occupational disease incidence and index of person-endangerment related to work conditions were calculated. The mentioned indexes were ranked, according to an ordering criterion, with the calculated sum of ranks determining the selection of the safest mine. The abovementioned method can also be used for selecting the safest copper ore mine or other mines, conducting exploitation of raw materials in any period of time.

\*\*\*

### **Articles published in proceedings of Session no 3: COAL MINING – CHANCES AND CHALLENGES**

JERZY ANTONIAK., *Silesian University of Technology, Gliwice, Poland*

### **NEW TECHNOLOGIES OF MINE TRANSPORT AS BASIS OF COAL PRODUCTION CONCENTRATION FROM LONGWALLS**

Increase of production concentration from coal longwall faces started at the beginning of the nineties in the last century (Staszic and Czczcott Collieries). An increase of production concentration from one longwall has become possible due to an implementation of the state-of-the-art belt conveyors, equipped with soft start systems and with slow burning and anti-electrostatic rubber belts of high strength (with fabric-ply cord – up to 3150 N/mm and with steel cord – up to 4500 N/mm) for a transportation of the run-of-mine. Belt conveyors of relatively big lengths (1000–2000 m) with the belt of the width 1200 or 1400 mm are commonly used. The belt speed does not exceed 4 m/s. An introduction of belt conveyors (of linear, curvilinear, horizontal and inclined ways) to underground mines has given them big economic benefits, resulting from closing down an excessive number of shafts and from stopping the transportation of the run-of-mine, using underground mine railway systems. Economic benefits also result from a wider and wider use of sub-level mining. In the scope of belt conveyor technology the following tasks can be expected: designing and production of energy-saving belt conveyors of the belt width 1400 and 1600 mm; developing and implementing slow burning and anti-electrostatic belts with the cord made of aramid strands; designing model constructions of discharge stations, ensuring a significant protection of the belt and a full protection against dusting; an intensification of activities aimed at an implementation of electro-mechanical dispatching units and solving other important problems in the scope of the run-of-mine conveying. The changes in the run-of-mine conveying systems correspond to deep changes in the means and systems used for a transportation of materials, machines and personnel. A transport by railways with rope drive has been replaced by suspended monorails and floor-mounted railways, driven by diesel and battery locomotives as well as articulated diesel tyre-mounted vehicles. More and more often rack-and-pinion drive in connection with friction drive is used. Many mines introduce a containerization of materials and an integrated transport

V. Arad, S. Arad, R. Moraru, G. Băbuț, T. Goldan, I. Neag, *University of Petrosani, Romania*

### **GEOMECHANICAL STUDY ON METHANE EMISSIONS IN VALEA JIULUI COAL BASIN, ROMANIA**

An analysis between coal and geomechanical characteristics was realized based on underground measurements. The dependencies between coal and rock porosity and methane concentration were assessed and between porosity, permeability and methane flows from the coal seams. Based on the theoretical and experimental research carried out, a mathematical model describing the coal bed methane emissions was developed for the specific conditions within the Valea Jiului coal basin, in Romania.

V.D. Baryshnikov, L.N. Gakhova, *Institute of Mining, Siberian Branch, Russian Academy of Sciences, Russia*, A.N. Cherepnov, *ALROSA Joint-Stock Company, Mirny, Republic of Sakha (Yakutia), Russia*

**GEOMECHANICAL ESTIMATE AND CONTROL OF THE CAP PILLAR CONDITIONS WHEN CHANGING FROM THE OPEN TO UNDERGROUND MINING**

With changing from the open to underground mining, a cap pillar is formed below an open pit bottom, and mining is carried out by slicing with backfilling. The authors have analyzed stress-strain state of this cap pillar, and, by mathematical modeling, have estimated preliminary variations in the stress-strain state and parameters of movements of the cap pillar at different stages of secondary working. Based on that, the control methods and instruments are chosen to monitor the cap pillar conditions. The comprehensive geomechanical research and observation data have made it possible to specify deformation features in the cap pillar and to make recommendations on stoping.

G. Ceglarska-Stefańska, A. Nodzeński, K. Czerw, S. Hołda, *AGH University of Science and Technology, Department of Fuels and Energy, Kraków, Poland*  
**COAL-MINE GASES SYSTEMS IN THE ASPECT OF METHANE RECOVERY AND CO<sub>2</sub> SEQUESTRATION**

For many years, one of the issues undertaken by Department of Fuels and Energy are investigations of the system coal – mine gases in the aspect of outburst problems, methane recovery and limiting greenhouse gases' emission by carbon dioxide sequestration in geological strata containing coal. The basis for description of these kinds of phenomena in these relations are the results of researches of sorptions/desorptions of single gases (CO<sub>2</sub>, CH<sub>4</sub>) and their mixtures of thereof of different percentage. The experiments were conducted at the temperature of 298 K, by the application of classical volumetric method on grain samples, plates (10 × 10 × 5 mm) and lump samples, cut of pieces of primal coal (cubicoids 20 × 20 × 40 mm). The aim of tests conducted on such various coal samples was finding relations between coals' porosity, sorption capacity and gas capacity in a broad range of gas pressures. The presented research results indicate the influence of coals' petrographic composition, their rank and the dozed gas pressure on capability for gaining a sorption equilibrium state in the researched systems. Firstly, they represent higher affinity of the tested coals towards CO<sub>2</sub>. Carbon dioxide injected into coal seams will not only be sorbed, but it will also replace the sorbed methane. Moreover, tests of sorptions of gas mixtures lead us to finding an inverse of selectivity of these gases for coals of different ranks.

Lidia Gawlik, *Mineral and Energy Economy Research Institute of PAS, Kraków, Poland*  
 Eugeniusz Mokrzycki, *MEERI PAS, AGH University of Science and Technology, Kraków, Poland,*

Roman Ney, *MEERI Polish Academy of Sciences, Kraków, Poland*

**ACCEPTABILITY OF COAL – A WAY TO ENERGY SAFETY**

Coal is and will be an important raw material for the world's energy needs. Its resources are large and its geographical distribution is fairly even. Technical and economical accessibility favors the growing use of coal, especially in developing countries. However, coal is seen as a danger to the environment and this point of view hampers the development. Lack of the acceptability of coal is very often caused by the shortage of knowledge about clean coal technologies, which limit or even remove the negative impact of coal on the environment. The article presents the development of clean coal technologies. This development of both coal burning technologies and the technologies using coal as a chemical raw material gives the possibility of using coal energy in the way which is most effective and does not harm the environment. The article presents the plans of the EU concerning safe supply of Europe with energy and names projects aiming at zero-emission use of coal.

V.I. Klishin, Yu. M. Lekontsev, P.V. Sazhin, *Institute of Mining, Siberian Branch, Russian Academy of Sciences, Novosibirsk, Russia*

**DYNAMIC PHENOMENA IN COAL MINES – PRACTICE OF PREVENTION BY DIRECTIONAL ROCK MASS HYDROFRACTURING METHOD**

The paper dwells upon the directional hydrofracturing method developed at the Institute of Mining SB RAS, and describes the method implementation facilities with their parameters substantiated. The authors show the effect of the method application at the Kuznetsk Basin coal mines for the purpose of reaching the higher safety and productivity of stoping in various process flow charts, for instance, deloading of protective pillars in mine workings conserved for re-use, decrease in spacing between primary roof cavings when powered roof support gets out of an installation chamber, redistribution of bearing pressure in near-face area of a coal seam, rock-burst and outburst hazard decrement.

I. Onica, E. Cozma, B. Cozma, *University of Petroșani, Romania*  
G. Chiril, *National Hard Coal Company Petroșani, Romania*

**PERFORMANCES AND FAILURES IN THE TOP COAL CAVING MINING**

The top coal caving mining methods and technologies were adapted to the specific geo-mining and technical-mining conditions of the Jiu Valley hard coal basin. In the beginning of this paper, there are presented, synthetically, the main top coal caving methods and technologies used in this coal basin and the technical and economical performances obtained. The main part of this paper is focused on the analysis of certain grave accidents produced within the framework of these mining methods, ended with important economical losses, accidents and human life losses, because of the development of certain geomechanical phenomenon, some associated with methane gas explosions. Finally, there are presented a series of solutions for to prevent in the future the similar phenomenon.

I. Onica, E. Cozma, *University of Petroșani, Romania*

**STRESS AND STRAIN STATE DEVELOPED AROUND THE LONGWALL FACES IN THE JIU VALLEY COAL BASIN**

In this paper, there is presented a synthetic analysis of the results of the measurements provided in the last 50 years, in the hard coal basin of Jiu Valley (Romania) regarding the stress and strain state developed around the longwall faces, situated in the thick coal seams, mined within the horizontal and inclined slices and with the caving rocks roof control.

S. SHIMADA, *Department of Environment Systems, Graduate School of Frontier Sciences, The University of Tokyo, Japan*

**RECENT COAL UTILIZATION TECHNOLOGY IN AN ENVIRONMENT CONSTRAINED SOCIETY IN JAPAN**

Japan imports about 200 Mt coal annually and about 60% of them is used for power generation. Coal, as an abundant primary energy resource, has been considered as a key resource to maintain a stable future energy supply. However, compared with other primary energy resources, the use of coal usually creates high environmental burden. To overcome this disadvantage, clean coal technology (CCT) is proposed and regarded as a key bridging technology to the future hydrogen society. The recent Japanese technology developments in CCT and future prospects are summarized. The highlight of the recent technology is IGCC (Integrated Coal Gasification Combined Cycle) and the future one is IGFC (Integrated Coal Gasification Fuel Cell Combined Cycle). Pilot plant of air blown IGCC with 250 MW output has started last year at Nakoso City and its net thermal efficiency is expected to be 42%. Geological CO<sub>2</sub> storage is one of the fields concentrating the technological developments in Japan. CO<sub>2</sub> emitted from coal firing power station is captures and stored in a geological formation (CCS). Cleaner use of coal resources through CCT and CCS creates the emission free coal energy system.

M. Turek, Z. Lubosik, *Central Mining Institute, Katowice, Poland*

**ASSESSMENT OF MINING POSSIBILITY OF HARD COAL SEAM  
REMAINDERS**

During the processes of hard coal extraction non-mined parts of seams called remainders are left because of different reasons, e.g. safety aspects, mining and technical conditions, application possibility of the given extraction system, exploitation profitability and other factors. Safe and economically profitable extraction of these reserves is advantageous, because it leads to the improvement of the seam extraction ratio, increase of the reserves basis of the mine and time extension of its activity, improvement of work conditions in workings existing in the zone of remainder impact, growth of the mine's profit etc. The decision, which of these remainders could be mined, ensuring an appropriate safety level and economic efficiency, should be based on an assessment suitably carried out. Such an assessment is difficult, because a number of parameters should be taken into consideration, both these characterising the given remainder as well as those resulting from the extraction system applied. In this paper a way of carrying out of an assessment relating to the possibilities of mining of hard coal seam remainders was proposed. Attention was drawn to the changing prices on the hard coal market. The assumptions regarding the preparation of deposit development plans, definition of coal seam remainders and the results of a preliminary assessment of reserves left in remainders of coal seams in the Upper Silesian Coal Basin were presented. The impact of selected geotechnical factors concerning the extraction possibility of these coal seam parts was described. The algorithm of proceeding in the assessment process of operation safety and work conditions in the remainder as well as the algorithm of seam remainder selection and its inclusion in the extraction process were presented. Furthermore, a way of economic verification of extraction of hard coal seam remainders was proposed. The problems presented in the paper should facilitate the decision on coal seam remainder extraction, what leads in consequence to a more rational deposit management.

Klaus Weyand, *Becker Mining Systems AG, Friedrichsthal, Germany*

Tomasz Budniok, Józef Rusinek, *Becker Warkop Sp. z o.o., Świerklany, Poland*

**INNOVATIVE SOLUTIONS FOR COAL MINING TRANSPORTATION SYSTEMS**

The paper presents experiences of mines in application of different solutions concerning the transport of materials and machines for longwall systems. A suspended cog wheel-driven haulage system (power 80 kW) and cog wheel-driven haulage system with a combustion haulage gear (power 125 kW) have been introduced for exploitation. The DZK (pneumatic) haulage gear is used for any manoeuvre functions. In order to improve monitoring of the route and safety conditions an intrinsically safe TV camcorder and a local monitor installed in the operator's cabin have been introduced. In addition to it a system of wireless communication BeckerCom Leaky Feeder has been introduced.

Krzysztof Wodarski, Andrzej Karbownik, *Silesian University of Technology, Gliwice, Poland*

**RISK MANAGEMENT IN A LARGE PROJECT IN THE HARD COAL MINING  
INDUSTRY**

While deciding whether or not to undertake an investment project we first have to be sure that its performance and operation in the future will be efficient from the economic point of view. The investments in hard coal mining are ones of the largest both in terms of their scope and in terms of their outlays and performance time. Performance of the projects is connected with the same risk. This paper deals with the problem of managing risk of a large investment project insisting in extension of a colliery. The proposed risk assessment has been based on the Monte Carlo method

Jialin Xu, Mingguo Qian, Xiexing Miao, Wenqi Lai, *Department of Mining Engineering, China University of Mining & Technology, Xuzhou, Jiangsu, China*

**GREEN MINING OF COAL RESOURCES HARMONIZING WITH ENVIRONMENT**

To the serious environment problems of coal mining, a new concept of green mining is advanced. The connotation of green mining is to view and treat coal, coal-bed methane, ground water, rock waste and any other useful resources in abroad sense as "resources". Its basic starting point is based on the law of

strata movement to prevent or to alleviate the adverse influence of coal mining on other resources and the environment as far as possible. The goal is to maximize the economic and social benefits. The technique frame of green mining includes water-preservation in mining areas, coal mining to retard surface subsidence, simultaneous extraction of coal and coal-bed methane, reducing of rock waste, underground coal gasification, etc.

\*\*\*

**Articles published in proceedings of Session no 7:  
ORE MINING – TRENDS AND CHALLENGES**

Neşet Acarkan, Gülay Bulut, Alim Gül, Olgaç Kangal, Fırat Karakaş, Fırat Karakaş  
*Istanbul Technical University, Istanbul, Turkey*

**AU-AG RECOVERY FROM COMPLEX PB-ZN ORES**

Gold and silver concentration processes usually consist of gravity separation, flotation, cyanidation or a combination of these processes. Actually, the choice of those processes depends on the mineralogical characterization and gold and silver content of the ore. Flotation has been applied on native and free gold and silver particles for many years. The floatability of gold and silver particles depends on the modifiers and collectors. This paper presents the recovery of the Au-Ag from complex Pb-Zn ores. The lead-zinc ore sample containing 3.45% Pb, 3.15% Zn, 12.2 g/t Au and 256 g/t Ag was subjected to this experimental study and taken from Bolkardağ, Niğde, south eastern part of Anatolia. According to the mineralogical studies, the representative ore sample contains primarily native gold, electrum, native silver, and argentojarosite as gold and silver minerals, cerusite, anglesite, galena, pyromorphite, mimetite and plumbojarosite as lead minerals, smithsonite, hydrozincite, hemimorphite, adamite and sphalerite as zinc minerals, limonite, hematite, goethite, pyrite, magnetite and siderite as lead minerals and quartz, feldspar, albite and muscovite as gangue minerals. Beneficiation of complex lead and zinc ore was investigated using flotation method. Various parameters such as particle size, flotation stages, collector type, collector amount, control reagents were investigated to recover of gold and silver bearing minerals. At the end of the experimental studies, the flotation experiments performed with Aero 208 + Aerophine 3418 A (350 + 350 g/t) collectors at pH 4.5 gave the best result. -38 microns particle size and 1000 g/t of Na<sub>2</sub>SiO<sub>3</sub> as depressant were used at these conditions. At the end of the experiments, a process was designed for evaluation of the ore. According to the process, a concentrate having 920 g/t Au and 10100 g/t Ag can be obtained with the recoveries of 54.1% and 31.1%, respectively.

Ivan Antonov, Ivan Vladov, Valentin Ketipov, Kiril Chobanov, Angel Tomov,  
*Bulgaria*

**NEW CRUSHING TRANSPORT SYSTEM AT COPPERMINE ELLAZITE-MED AD**

The mine floatation complex Ellazite AD has been operational since 1982. It processes copper porphyry ores with design capacity of 10 millions ton. The complex is situated at two platforms. There is an open mine and the Primary Crushing Department for the ore in the north of the ridge of Balkan. In the south of the mountain there is a floatation plant, waste depot and the waters supply system. They are connected with the help of a rubber transport conveyor, 7 km long, installed in a tunnel with a slope of 7%. In the process of exploitation the transport distance from the obtaining locations to the Primary Crushing Departments have increased. In the last few years there is constant tendency for price increase of the petrol products. The construction of a new Crushing Transport system aims to reduce that negative impact by decreasing the share of the automobile transport and increasing the conveyor one. As a result new rubber transport conveyors are added to the existing one, all installed in tunnels and the crushed ore material is stored on the number 1 open storage. The connecting tunnel is driven in predominantly hard rock, but one part of the tunnel passes through inhomogeneous rock and soil materials, which require a special method. Also the problem with the ventilation system is specifically addressed in order to avoid the inhalation of gases by the staff, servicing the Crushing Department and the tunnels. The existing infrastructure of the site is considered so as not to affect the intense production schedule of the complex. The realization of the new Crushing Transport system will help reduce the production expenses, the dust pollution, gas and vapour emission and to increase the reliability of the transport in the mine during the winter months.

A.A. Eremenko, V.A. Eremenko, *Institute of Mining, Siberian Branch, Russian Academy of Sciences, Novosibirsk, Russia*

A.P. Gaidin, *“Evrazruda” Joint-Stock Company, Novokuznetsk, Russia*

### **GEOMECHANICAL PROBLEMS OF IRON-ORE MINING IN THE ALTAI-SAYAN MOUNTAINOUS AREA**

Under discussion is a new development trend for the enlargement of metallurgical raw-material base in Western Siberia, namely, Altai-Sayan mountainous area, described by the higher seismic activity. On the strength of the studies into the stress-strain state of the rock mass, the efficient patterns and parameters have been specified for a geotechnology of mining at the rockburst-hazardous ore deposits. The new technology allows for the compatibility of production processes during ore drawing, hauling, crushing and transportation. Also, it makes provision for the streamlined production and enhanced yield in the deeper mining conditions. The higher mining safety and effectiveness measures have been elaborated.

Hongtao Chu, Aimin Zhou, *Changsha Institute of Mining Research, Changsha, Hunan, National Engineering Research Centre for Metal Mining, China*

### **UNDERGROUND MINING METHOD FOR EXPLOITING WATERY ORE DEPOSIT OF METAL MINE IN CHINA**

This paper introduces the underground exploitation status quo and mining method for watery ore deposit of metal mine in China. Then comment on the mining method of watery ore deposit.

Iliya Kairyakov, *Bulgaria*

### **RESTORING THE MOLYBDENUM PRODUCTION IN THE FLOTATION PLANT OF COPPERMINE ELLATZITE-MED AD IN BULGARIA**

The present paper is about the restoration of the molybdenum production in the floatation fabric of Ellatzite-Med AD in Bulgaria with Vemco inert gas floatation machines, where the oxidizing of reagent sodium hydrosulphate is reduced to its possible minimum values. This solution will improve the economical indices of the plant.

## **Articles published in proceedings of Session no 8: OPEN PIT MINING - TRENDS AND CHALLENGES**

Z. Kasztelewicz, J. Klich, W. Koziół, M. Zajączkowski, *AGH –University of Science and Technology, Krakow, Poland*

### **SELECTED EXAMPLES OF RECLAMATION OF POST-MINING AREAS IN THE BROWN COAL MINING IN POLAND, GERMANY AND THE CZECH REPUBLIC**

The paper presents an attempt of a general comparison of the current achievements in the scope of reclamation and revitalisation of post-exploitation areas in the main three countries where brown coal is mined in Europe, i.e. in Poland, Germany and in the Czech Republic. A short characteristics of the brown coal industry has been presented for these countries in the scope of acquiring areas for mining operations and disposing land after completion of reclamation activities. The prevailing reclamation is focused on agricultural, forest, recreational and water uses. The paper presents several selected characteristic of the facilities in Poland, Germany and the Czech Republic, which prove a very serious attitude of mining companies to protection of the environment, especially to reclamation and revitalisation of post-exploitation areas. The examples in the form of reclamation and management of post-exploitation headings with a view on water and recreation areas, skiing tracks, horse-riding centres, motor car training grounds, artificial water courses or various museum facilities help persuade the local communities to accept mining activities. Nowadays, this acceptance is a very important factor which determines further growth of brown coal mining.

Z. Kasztelewicz, J. Klich, W. Koziol, K. Polak, M. Zajaczkowski, *AGH – University of Science and Technology, Krakow*, K. Koziol, *BOT KWB Belchatow S.A., Belchatow, Poland*

**METHODS OF LIGNITE EXTRACTION AND UTILIZATION IN THE 21ST CENTURY BEARING THE INFLUENCE ON THE ENVIRONMENT**

At the present decade of the 21st century, there has begun a worldwide discussion on strategic directions of a lignite exploitation development for the next 10 years of the current century, thereby on a world's power industry shape. Today and in the near future world needs to double, and in 30-40 years even to triple, current electricity production. Similar situation is in Poland. Up to 2030, according to the various estimations, current electricity production in Poland should be at least doubled. Either there are opinions, that energy demand will be even greater. Whole world, including Poland, has large lignite resources, which can be sufficient enough for next 300 years. That is way the constant works on a utilization methods development and lignite usage should be marked as a priority works for both lignite mining and power industry that is based on that kind of fuel. Every developed method can be competitive and commonly used, if it allows to produce low cost energy and the smallest negative influence on the environment. In the article, there are presented achievements of lignite branch in Poland in the range of open cast technique and technology as well as there are discussed previous mine outcomes in order to reclamation and post-mining management. Moreover, in the article there were discussed other possibilities of lignite extraction and lignite processing methods in the deposit, and eventual causes to the natural surrounding. In recent years there has been observed an increased interesting in lignite as a fuel, which is mainly caused by increased demands of environmental protection. Therefore there is rapid prices increase of other fuels (e.g. breakdown of the psychological price 100 USD per oil barrel) as well as uncertainty of imported raw materials supplies, such as oil, natural gas or even uranium ores.

Z. Kasztelewicz, J. Klich, W. Koziol, M. Zajaczkowski, *University of Science and Technology, Krakow*, K. Koziol, *BOT KWB Belchatow S.A., Belchatow, Poland*

**LIGNITE-BASED POWER PLANTS IN POLAND – CHANCES OF DEVELOPMENT IN THE 21ST CENTURY**

Planned by the UE 20% limitation of CO<sub>2</sub> in the nearest future and significant greater restrictions in longer-terms could stop building of new power plants in Poland. The article presents a chance of development lignite-based power plants in the 21st century. In these power plants took place significant limitation of SO<sub>2</sub>, NO<sub>x</sub> and dust for last years, but substantial limitation of CO<sub>2</sub> hasn't been still achieved. Presently implemented technologies are aimed at limitation of elementary emission of CO<sub>2</sub> by installation of energy units with large power and high watt-hour efficiency (like the units 833 MW in Belchatow and 464 MW in Patnow). It seems that only one available solutions of this problem is capturing and CO<sub>2</sub> sequestration, alias CSS technology. Currently in Europe, mainly in Germany there are built pilot installations of low-emission or non-emission power plants based on lignite. In the future it seems that these technologies will be implemented directly in polish power plants. They could be: increase of the power units efficiency due to supercritical steam parameters, due to drying the lignite, due to the technology of combustion the lignite in oxygen or electricity production due to IGCC technology. The fact of higher CO<sub>2</sub> emission the power industry based on lignite stands in the front of the greatest challenges and at the same time threats of the reduction of contaminative substances that pollute the environment. Observed in recent years an increased interest in coal as a fuel is caused first of all by increasing environmental protection restrictions. Therefore there is also a rapid growth of the prices of the other primary energy carriers (e.g. breakdown of the psychological price 100 USD for oil barrel) as well as uncertainty of deliveries of imported raw materials such as oil, natural gas or uranium ores. The paper presents the state and the main chances of development in lignite-based powers stations in Poland.

Jerzy Bednarczyk, Barbara Rogosz, *Poltegor Instytut IGO, Wrocław, Poland*

**PROSPECTIVE STRATEGIES OF TECHNOLOGY OF ENERGETIC UTILIZATION OF BROWN COAL IN CONDITIONS OF GREAT LIMITATION OF CARBON DIOXIDE EMISSION**

Large balance resources of brown coal amount 25 billion tones and occur in six coal basins- three mined and three prospective. The quantity of brown coal in Poland forces a research and technological personnel to intensive efforts aimed at elaboration of economical and ecological technologies of brown coal output and processing, particularly by limitation of emissions of polluted gases from power plants. Significant limitation of SO<sub>2</sub> and NO<sub>x</sub> took place recently, but substantial limitation of CO<sub>2</sub> hasn't been yet achieved. Presently implemented technologies are aimed at limitation of elementary emission of CO<sub>2</sub> by installation of energy units with large power and high watt-hour efficiency. This direction has been initiated in existing brown coal basins in the country. Planned by EU 20% limitation of CO<sub>2</sub> in the nearest future and significantly greater restrictions in longer-term will stop building of new power plants. European Commission has already considerably restricted the limit of CO<sub>2</sub> for Polish power industry for 2007. As a result, it is possible to acquire rights for emission of one tone of CO<sub>2</sub>, which amounts 10 Eurocents. Those rights are valid until April 2008. It is estimated, that new rights will define lower quantity of CO<sub>2</sub> emissions. This may cause a significant increase of prices of the right to emit 1 tone of CO<sub>2</sub> to more than 20 Euro. Limitation of electric energy production or increase of production costs will be a result of the price rise. This is a huge challenge for coal and power industry in a range of selection of strategy of large brown coal reserves utilization. It also forces to participation in world competition in elaboration of new technology enabling considerable limitation of CO<sub>2</sub>. An attempt to present its development and fulfillment of requirements has been made in the paper.

L. Gawlik, Z. Grudziński, *MEERI of PAS, Krakow, , Z. Kasztelewicz, AGH University of Science and Technology, Krakow, Poland*

**DETERMINING BROWN COAL PRICES EQUIVALENT TO HARD COAL PRICES**

In the recent years, 33–35% of electric power in Poland is produced basing on brown coal. Prices of brown coal are influenced by many factors. Those are such elements as the specific of the coal itself, conditions prevailing in the power market as well as macroeconomic conditions. The paper fixes the conditions which have to be met by brown coal prices to remain a competitive fuel for power production. Basing upon hard coal prices, the coefficient for recalculating hard coal prices into equivalent brown coal prices was calculated, on such level that production cost of energy unit from brown coal was not higher than cost of power from hard coal. Applying the calculated coefficient, the maximal level of brown coal prices deriving from competitiveness with imported hard coal was calculated. In the recent years, a strong growing trend of hard coal prices can be observed in the international markets. Maximal level of brown coal prices in relation to w international hard coal prices can be estimated at the level of ca. 81 PLN/ ton, while in case of steam hard coal combusted by Polish power stations, at the level of 61 PLN/ ton.

\*\*\*

**Articles published in proceedings of Session no 11:  
17<sup>TH</sup> INTERNATIONAL CONFERENCE ON AUTOMATION IN  
MINING ICAMC`2008**

E. Mataradze, N. Chikhladze, E. Chagelishvili, D. Kukhalashvili, *Mining Institute, Tbilisi, Georgia*, T. Krauthammer, *Center for Infrastructure Protection and Physical Security, University of Florida, Gainesville, USA*

**WIRELESS SYSTEM FOR THE IDENTIFICATION OF UNAUTHORIZED EXPLOSIONS AND ACTIVATION OF PROTECTIVE DEVICE IN UNDERGROUND FACILITIES**

This paper presents the outcomes of the studies conducted to select accurate criteria for blast identification in underground facilities and to design wireless system of activation of a defensive device. A pro-



posed wireless system of activation consists of transmitter and receiver modules. A transmitter module contains a sensor, a microprocessor equipped with a blast identification software and a transceiver, which serves to transmit an encoded signal at the frequency of 868.35 MHz. A receiver module has a transceiver, which serves to receive a signal at the same frequency, a microprocessor and a fail safe decoder, which produces an activation signal for the operation of an absorber. Tests were performed in laboratory and in explosion conditions in the underground experimental base of the Mining Institute. The testing has yielded the following results: the time span between the moment of receiving a signal by the sensor and the moment of activation of a start signal – 640 microsecond; the distance between a transmitter and a receiver in a direct tunnel – at least 150 m; in a tunnel with a 90° bending – 50 m.

*A. Zalogin, Certification Center of Explosion-Proof and Mine Electrical Equipment (NANIO CCVE), Moscow, Russian Federation*

**ASSESSMENT OF INTRINSIC SAFETY OF SYSTEMS WITH CABLE COMMUNICATION LINES**

Assessment of intrinsic safety of systems with cable communication lines is complicated by the need to consider such factors as nonlinear discharge and distributed parameters of the circuit. When the parameters of the cable are fixed values the discharge current considerably depends on the length of the connected cable. Energy released in the discharge and discharge time have maximum values at a specific cable length. In the optimum point the value of energy released in the discharge and discharge time exceed their corresponding values in the circuit without cable ( $W - 131.5$  and  $66.8 \mu\text{J}$  and  $T_{\text{dis}} - 55$  and  $31.9 \mu\text{s}$  accordingly). Reduction of discharge energy after the optimum point is reached shows that at further increase of cable length to about 10 km the circuit becomes more intrinsically safe than without cable. The length of cable has a significant effect on operation of spark protection unit of power supply. Comparison of discharge energy and discharge time shows that at cable length up to 1 km energy characteristics of discharges in the circuit with a power supply which switches off on circuit switching are much lower than those of discharges in the circuits with a power supply source without controllable spark protection units. At cable length of 2-3 km the effect of controllable devices is negligible. At cable length over 3 km the characteristics of discharges in both types of circuits are identical. The results of calculation of cable effect on the parameters on which intrinsic safety of the circuit depends (discharge energy and time, signal value and delay time of signal, which switches off power supply source) allow to conclude that intrinsic safety of circuits with cable lines can be evaluated by computational methods.

*Janusz Ostrowski, AGH University of Science and Technology, Kraków, Poland.*

**NEW METHOD OF ASSESSMENT OF DAMAGES THREAT TO BUILDING OBJECTS IN THE MINING TERRAIN**

The mining-induced surface deformations are the reason of damages to buildings. The paper presents new method the assessment of threat to building, which can be accomplished by the comparison of so-called the predicted value of impassable horizontal strain to so-called the value of horizontal strainmarking critical resistance of the building.

*Ryszard Hejmanowski\*, Agnieszka Malinowska\*, Tomasz Stoch\*, Piotr Plucinski\*\*, Marek Warchala\*\*, Ryszard Kosior\*\*, \* AGH University of Science and Technology, Faculty of Mining Surveying Engineering, Kraków, Poland, \*\* KGHM "Polska Miedź" SA, O/ZG "Rudna" in Polkowice, Poland.*

**NEW INTERPRETATION OF GPS MEASUREMENTS RESULTS**

A project of GPS deformation measurements has been provided for the copper ore mine "Rudna", belonging to KGHM "Polska Miedź" S.A. Over 300 benchmarks have been measured since 2000. Extensive measurement results enabled thorough analysis of horizontal and vertical movements on the terrain surface. On the basis of this interpretation an area of dynamic and vanishing mining influence was determined. Moreover a modern GPS measurement allowed observing point movements following the rock mass tremors. The research presented in this paper reveals a relation between vertical movements of benchmarks and rock mass tremors.

MICHAEL BERGMAIR\*, MARTIN SCHEIBER\*\*, \* *iC consulenten ZT GmbH, Bergheim, Austria.* \*\* *S Consult Management GmbH, Innsbruck, Austria.*

**REHABILITATION OF OLD MINES IN URBAN AREAS METHODS AND EXPERIENCES**

During the years 2005–2007 the treatment of a gypsum mine, operated approx. 1845–1901 southwest of Vienna, Austria, was finished successfully. Following geological, hydrogeological and historic investigations, an exploration phase consisting of geophysical survey and a drilling campaign including video logging of each bored hole was executed. Risk assessment of the data collected lead to the conclusion, that grouting the old mine workings would be the only possibility way to reduce the hazard of crown holes on surface. During the treatment approx. 16,000 m<sup>3</sup> grout were brought into the old mine workings through over 80 bored holes. The filling results were verified by core drillings and checking the ration between estimated and actual filled mass.

Violetta Sokola-Szewiola\*, *The Silesian University of Technology, Gliwice, Poland.*

**MODELS OF DEPENDENCES BETWEEN INDUCED SEISMIC ACTIVITY AND OBSERVED DEFORMATIONS OF SURFACE IN THE AREA OF THE CONDUCTED LONGWALL EXPLOITATION**

This paper presents models of dependences between seismic activity (of the  $N$  number and seismic energy of tremors  $E$ ) induced by conducted longwall exploitation and observed quantities of ground surface deformations. In the models, the observed quantities of ground surface deformations have been described with subsidence through cross-section areas  $P_w$  along observation line parallel to the advancing longwall face. Linear models of regression with a single independent variable have been adopted. Dependences between accrued quantities of the total number ( $N$ ), and total seismic energy of tremors ( $E$ ) and increasing quantities  $P_w$  were determined. The article presents verification of models for longwall exploitation conducted in the area of Upper Silesia Coal Basin by the hard-coal mine KWK "Ha-limba". The surface  $P_w$  has been determined basing on the results of geodetic measurements (levelling and angle-linear measurements) carried out on an observation network implemented in the area of exploitation. Measurements carried out at the observation line located approximately within the symmetry axis of the longwall field perpendicular to the face of the longwall were applied. The data concerning the induced seismic activity was obtained from the Mining Geophysics Station. Verification of the models was carried out for increasing quantities of  $E$ ,  $N$  and  $P_w$  in time periods of realized cycles of geodetic measurements. For a determined regressional dependence of  $E$  in relation to  $P_w$  at the significance level of  $p < 0.05$ , it has been found that there is significant influence of the variable  $P_w$  on  $E$ . The value of the determination coefficient  $R_2$  equalled 0.9772. For the determined regressional dependence of  $N$  in relation to  $P_w$ , the value of the determination coefficient  $R_2$  equalled 0.9905. The regression coefficient  $b$  and the correlation coefficient are significantly different from 0 (zero) at the significance level of  $p < 0.05$ . The analysis of remainder variables in the time function, assorted values and an independent variable excluded any reservations regarding adequacy of the considered models. The models proposed in this paper may be used for development of a method for seismic risk forecasting.

Aleksander Wodynski\*, Karol Firek\*, Janusz Rusek\* *AGH University of Science and Technology, Kraków, Poland.*

**ASSESSMENT OF TIME AND MINING EXPLOITATION EFFECTS ON THE TECHNICAL WEAR OF PREFABRICATED PANEL BUILDINGS**

The paper presents the results of the analysis of the course of technical wear in time and the studies of the relationships between mining tremors and the technical wear of prefabricated panel buildings localized in the mining area of Legnica-Głogów Copper District (LGOM). The base for the studies was the authors-made database on the technical state and potential causes of the accelerated wear, containing the data on 129 objects. The temporal trend of technical wear of buildings and the impact of mining tremors on this wear was studied.

Aleksander Wodynski\*, Wojciech Kocot\*, Jacek Kurzak\*\*, \* AGH University of Science and Technology, Kraków, Poland. \*\* Kompania Weglowa SA, KWK "Ziemowit", Poland.

**THE INFLUENCE OF STRUCTURE DEFECTS ON THE DISPLACEMENTS OF THE CONSTRUCTION ELEMENTS OF VIADUCTS SUBDUED TO THE IMPACT OF MINING EXPLOITATION**

The paper presents the results of the observations of multi-span viaducts during the exploitation of coal, carried out under the viaducts. The observations showed a significant impact of structure defects on the displacements of construction elements and, consequently, significant deviations from the values predicted for individual spans. At the same time the prediction for the whole object was correct.

\*\*\*

**Articles published in proceedings of Session no 13:  
CONTRIBUTION OF STRATA MECHANICS TO MINING  
TECHNOLOGY AND WORK SAFETY**

Marian Marschalko\*, Matej Fuka\*, Lubomír Třeslín\*, *Hornicko Geologická Fakulta, VŠB-Technická Univerzita Ostrava, Ostrava-Poruba, Czech Republic*

**MEASUREMENTS BY THE METHOD OF PRECISE INCLINOMETRY ON LOCALITY AFFECTED BY MINING ACTIVITY**

The paper evaluates the impact of undermining on the slope deformation in Staříč. For the purposes of such an evaluation, isocatabase maps, parameters of terrain deformations calculated for the point lying on the ground surface of the slope deformation and inclinometric measurements in two wells, out of which the first is situated on the sliding slope and the second in the vicinity of the landslide body, have been used. On the basis of the inclinometric measurements a slope deformation movement vector perpendicular to the rock and soil mass vector caused by undermining was identified.

E.P. Rusin\*, S.B. Stazhevsky\*, G.N. Khan\*, *Institute Of Mining, Siberian Branch, Russian Academy Of Sciences, Novosibirsk, Russia*

**KARST GENESIS AS A RESULT OF ACTIVITY OF ENDOGENOUS RING STRUCTURES**

The authors have founded a new hypothesis that relates various karsts' genesis, including hydrothermal-karstic ore deposits, and evolution of rock masses in the areas of endogenous ring structures. The hypothesis is backed by the fact that karstic manifestations stick to the ring morpho-structures. The presented substantiation grows strong with the physical and numerical modeling of the karst formation mechanics and comparison of the modeling results and field data.

**Article published in the proceedings of Session no 14:  
ECONOMICS, MANAGEMENT AND DESIGN  
IN THE MINING INDUSTRY**

K. Oraee\*, A.H. Bangian\*\*, A. Parhizkar\*\*\* \* *Stirling University, Sterling, UK.*  
\*\* *Islamic Azad University - Tehran South Branch, Mining Engineering dept., Tehran, Iran.*, \*\*\* *Islamic Azad University - Science & Research branch, Tehran, Iran.*

**ECONOMICAL MODELING FOR IDENTIFICATION OF BEST DRILLING CHOICE IN SUBLEVEL STOPING**

Sublevel stoping is an underground mining method which has a low level of production cost. As well main part of the production cost is related to the chosen drilling system in each stope. Developing a model for identification of best drilling choice through economical point of view in each case is the main

## **POSTER SESSION**

*21st World Mining Congress, 7-11.09.2008, Kraków, Poland*

---

objective of this paper. In order to develop the model about 150 stopes have been designed by hypothesized dimension and pattern. In each case production cost on account of the extracted ore unite has been calculated. A mathematical model was developed on the basis of the non-linear regression on out puts from calculation of the hypothesized designations which provides production cost based on thickness of ore body and height of production block. Verification of the developed model has been carried out on some random data and the adaptation ratio is on acceptable rates.

## A complete automation package for Mining Operations

### Completely integrated solutions deliver greater efficiency

Simine<sup>CIS</sup> integrated mining solutions include the control, monitoring, display, and optimization of mining production from excavation through transport to processing and secondary processes to include water treatment or storage. With Simine<sup>CIS</sup> CC (Control Center) and Simine<sup>CIS</sup> MES (Manufacturing Execution System), Siemens has developed solutions whose modular design, technical consistency, and specific mining features combine to provide a virtually unlimited number of ways to adapt mining control technology to individual processes and requirements.

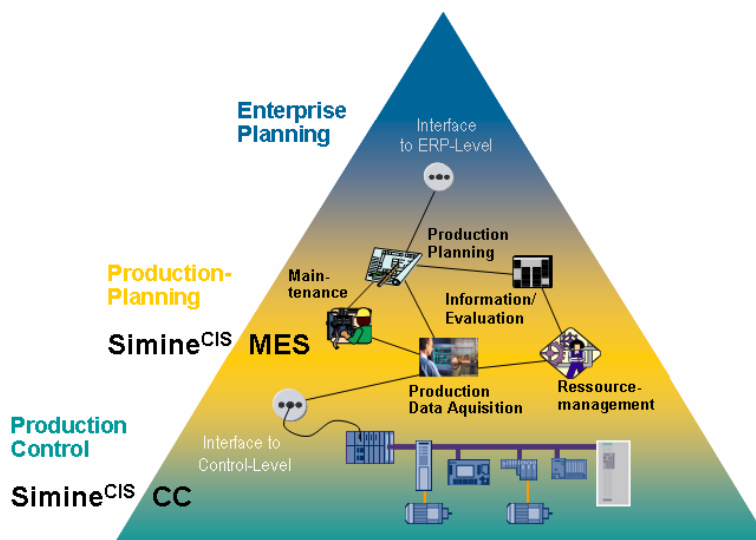

Fig. 1: Highest degree of integration - SIMINE<sup>CIS</sup> solutions

Simine<sup>CIS</sup> CC is based on the Siemens Simatic PCS7 production standard. Thanks to years of experience in both process and discrete control, Siemens has been able to put the Simine<sup>CIS</sup> CC mining automation solution onto a single in-house platform. As an end-to-end automation solution, it includes automation, communication, and data management covering extraction, transport, processing, and distribution of the mined raw materials.

#### Standard Simatic PCS 7 features

The unique scalable architecture of Simatic PCS 7 enables the same components to run from 100 I/O points in single machines up to huge applications with 100,000 I/O points. The open, integrated communication for the automation throughout the entire enterprise is a basic requirement that allows all units of the plant to interact based on industry standards such as Industrial Ethernet with components supporting 10/100 Mbit/s or 1000Mbit/s technology and Profibus, the Siemens field bus standard based on electrical or optical transmission technology. The wide range of intelligent field devices using industrial standards such as Profibus, Foundation Fieldbus, and HART means more decentralization in the field, which speeds the execution of applications and reduces processing costs over the entire life cycle of the plant.

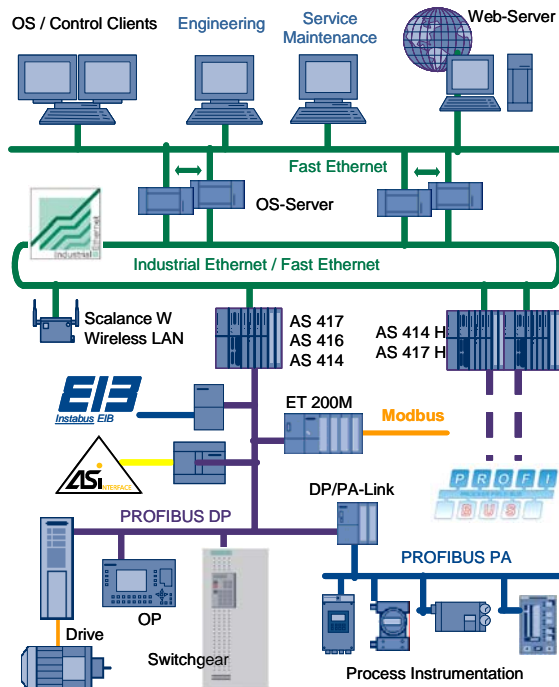

Fig. 2: Based on the wide Simatic product range - SIMINE<sup>CIS</sup> CC solutions

With regard to user-machine interaction, the flexible Simatic PCS 7 operator system can be customized to various plant sizes, process cases and customer requirements. Multi-user systems with up to 12 servers or 12 redundant pairs of servers are supported. In multi-client mode, OS clients can access data from one or more of the 12 servers/pairs of servers in parallel.

The Simatic PCS 7 web server based on Microsoft Windows supports remote operation and monitoring over the intranet/internet. For its part, the Simatic PCS 7 Maintenance Station supports plant asset management, including the administration and management of plant equipment, particularly I&C equipment, as well as all activities to retain or enhance the value of a plant.

### Production management

Siemens was one of the first to understand the challenges of MES in mining. Based on the integrated MES (Manufacturing Execution System) platform Simatic IT, which is a cross industry platform for production management applications, Siemens developed add-ons to meet the specific requirements of the mining industry.

Simatic IT provides a sophisticated framework environment that enables the modeling of the production processes and operation procedures, synchronizing and coordinating the functions provided by the individual components. The basic design approach, revolving around a production modeler and components, offer the unique possibility to build flexible and tailored solutions based on standards. Solutions build with the Simatic IT framework standardize operations at a high level while maintaining flexibility at the operational level. The modeling approach keeps end users solutions easy to maintain and modify while the open architecture supports the interfacing of higher- and lower-level computer systems as well as integration of third-party software modules.

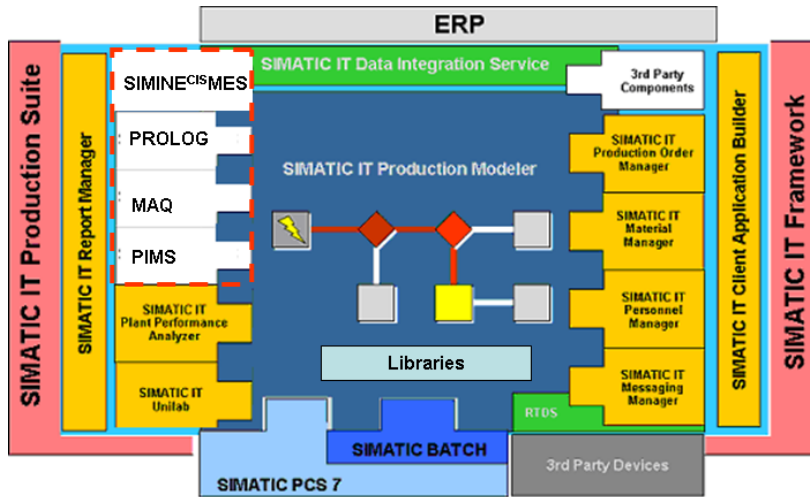

Fig. 3: SIMATIC IT Production Suite

The figure above shows how Simine<sup>CIS</sup> components plug directly into the Simatic IT framework. Industry-sector specific libraries represent Siemens solutions for the mining industry based on standard cross industry products.

**High level Unique Simatic IT performance**

Simine<sup>CIS</sup> MES is the Siemens response to the growing demands being made on production management systems for the mining industry. Advantages lie not only in the improved production planning capability, but in the consistent display of information across all processes.

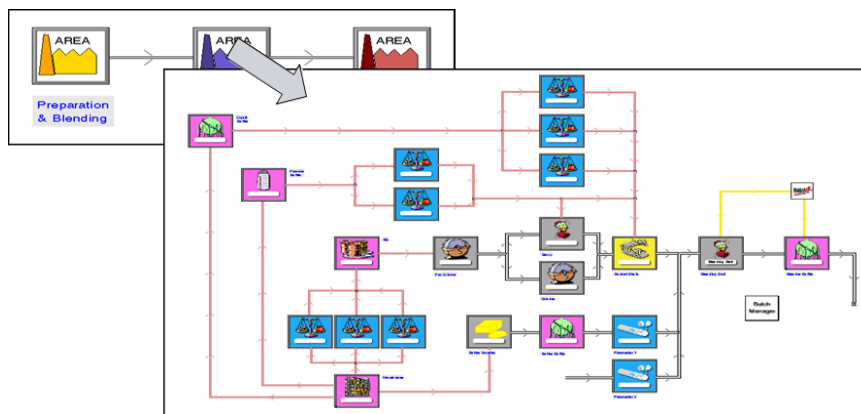

Fig. 4: The graphical workflow defines the behaviour of the system

As an online system, Simine<sup>CIS</sup> MES also closes the gap between the real-time automation process and transaction-oriented ERP. That enables management to make decisions based on real-time in-

formation, which enhances productivity and improves process availability. Based on Simatic IT, Simine<sup>CIS</sup> MES includes packages for:

- Production planning/supervision: PROLOG Library for production modeling, scheduling, order management
- Material management: MAQ Library for stock management, blending, material tracking
- Process information management: PIMS Library for KPI, OEE, reporting.



### **The right solution for mining and materials handling operations**

With its unique concept of Simine<sup>CIS</sup> based on the components of TIA (Totally Integrated Automation), Siemens' approach to automation stands for consistent and scalable performance from the shop floor to the management level. Combining mining expertise with the Simine<sup>CIS</sup> CC and Simine<sup>CIS</sup> MES components has put Siemens in an excellent position to adapt TIA systems and technology to the most diverse needs of the mining industry worldwide.

Author:

Karl-Heinz Gerlach, Siemens AG, Industry Sector, I IS MT MI Schuhstrasse 60  
91052 Erlangen, Germany, <http://www.siemens.com/mining>